

Offline adaptive control using virtual machining

Dr K P Karunakaran,

R Shringi and

Amit Kumar Singh

Cutting parameters are specified only in a few places in NC programmes, and their values are found to be conservative, subjective, and hence unoptimal. Moreover, the use of adaptive control, an online hardware for optimising these NC programmes, is expensive. Today, an equivalent software solution called 'Offline adaptive control' using virtual machining can be used as an extension of NC programming. Read on to delve deeper into this faster, cheaper and more importantly, proactive method.

Certain cutting parameters such as spindle speed and feed rate in the NC programmes, are specified by the NC programmer, based on his experience. These values are subjective and vary from person to person. On the other hand, if he uses standard machinability data, he is conservative as he has to choose these values for the worst case. Since the amount of material removed may vary considerably along the cutter path, the selected cutting parameters hold good only at a narrow region and are

inefficient anywhere else. Furthermore, these values are specified only in a few places in the NC programmes, for instance, after every tool change. Therefore, often hundreds of NC blocks may use the same cutting parameters. Such nonoptimal NC programmes lead to:

- Long machining time
- Excessive tool wear
- Poor surface finish
- High cost

Adaptive control

Adaptive control (AC) is an online hardware-based method to achieve optimal and safe cutting conditions. Cutting conditions prevailing at chip-tool and work-piece-tool interfaces may vary owing to tool wear, built-up edge formation, varying stock along tool path, material inhomogeneity, clogging chips, chipping off of cutting edges, breakage of the tool, chatter, vibrations, etc. Among these, varying stock along the tool path is predominant. The cutting conditions are understood through the measurement of cutting forces/torque, tool deflection/twist, vibrations (including ultrasonic and acoustic emissions and noise), temperature, spindle power, etc. These quantities are referred to as cutting zone parameters.

Cutting parameters are independent variables. These are primarily spindle speed 's' (in rpm) and feed rate 'f' (in mm/min). As the cutting conditions are indicative of the quality of machining and are considerably dependant on the cutting parameters, one can obtain favourable cutting conditions by appropriately controlling the cutting parameters. In AC, cutting parameters are continually modified, based on the continual

measurement of one or more cutting zone parameter(s) with the help of sensors in order to maintain favourable cutting conditions. Figure 1a shows the block diagram of the standard CNC control loop, which has only position and velocity control loops; the same with AC loop is given in Figure 1b. The sensors used for measuring various cutting zone parameters are listed in Table 1. A more elaborate schematic diagram of an adaptive CNC system is shown in Figure 2.

An adaptive CNC system executes the following three steps once every sampling interval:

Measure: Cutting zone parameter(s) are measured to understand the cutting conditions. Sensors are used for this.

Correlate: The cutting conditions are correlated with the cutting parameters and the changes to be made to the cutting parameters are calculated to maintain optimal cutting conditions. This computation is done by the AC processor.

Correct: Communicate to the CNC controller of the machine the changes to be made to the cutting parameters. This involves close interaction of AC processor with the CNC drive.

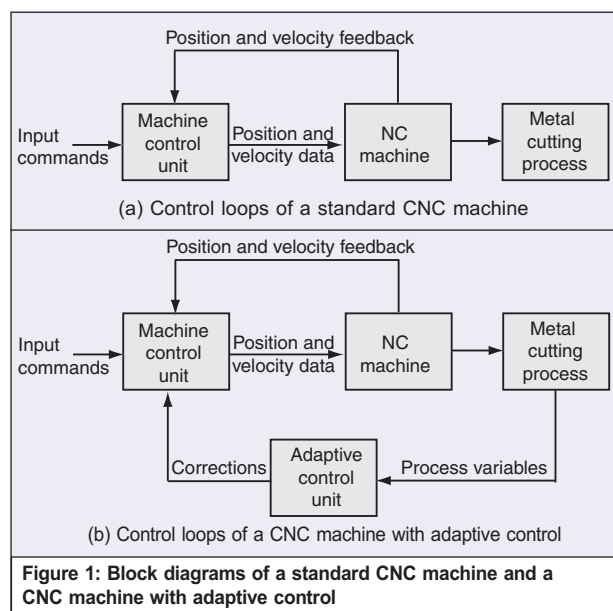

The user or a third party can do the first two steps of measuring and correlation. However, the last step of correction requires proprietary information related to the communication protocols of the CNC system. This step has made it difficult for the user or a third party to retrofit a CNC machine with an adaptive controller. The author has developed a novel method of retrofitting any CNC machine with an adaptive controller using its feed and/or spindle override features.

AC is available as an optional module in many CNC machines. Its primary goals are:

- Minimisation of machining time
- Maximisation of surface finish
- Maximisation of tool life

Unfortunately, these three are conflicting goals. If the spindle speed is increased, surface finish improves, but the tool life decreases due to rubbing. If the feed rate is increased, Material Removal Rate (MRR) increases but, in addition to higher tendencies for tool chip off and breakage, the surface finish is compromised due to chatter, vibration and tool deflection. Hence, one concentrates more on higher MRR during roughing, and surface finish is given more importance during finishing. The former is called Adaptive Control by Constraint (ACC) and the latter is called Adaptive Control by Optimisation (ACO).

ACC generally involves only one cutting zone parameter, which is maintained around a threshold value. For instance, for a given tool, there is a maximum allowable deflection that can be measured using a dynamometer. ACC will maintain the feed rate high enough to be

just below the maximum allowable deflection.

On the other hand, ACO may monitor more than one cutting zone parameters, say, tool deflection and cutting tool temperature. Higher feed rate may cause more tool deflection and higher spindle speed may cause more torsional deflection, rubbing and hence heat generation. Besides, tool wear is extremely sensitive to cutting speed and temperature. Thus, cutting speed and feed rate produce conflicting effects. Therefore, ACO defines a complex objective function called Merit Function (M) of the form $M=g(f,s)$. A typical plot of M is given in Figure 3. ACO will try to choose f and s such that M is maximised, ie, the desirable operating point is the top most point of the bell-shaped plot. In other words, ACC chooses f and s , to maintain a given cutting zone parameter such as deflection around a threshold value whereas ACO chooses f and s to maximise M . It may be noted that ACC is a subset of ACO. ACC is far simpler and cheaper as it requires just one sensor or no explicit sensor. Due to this ACC is more popular.

The primary benefits of AC are reduced machining time, improved tool life and quality. The additional benefits are:

- It prevents damage to the tool, work-piece & machine, and injuries to the operator

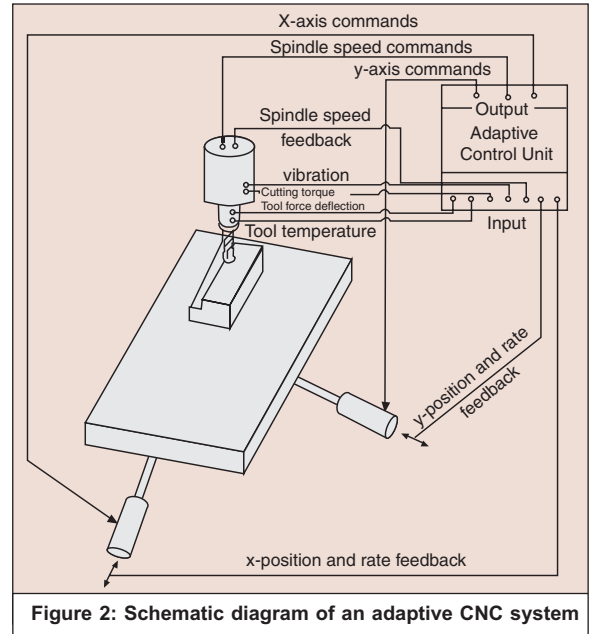

Figure 2: Schematic diagram of an adaptive CNC system

- It removes subjectivity arising out of different skill levels of the NC programmers

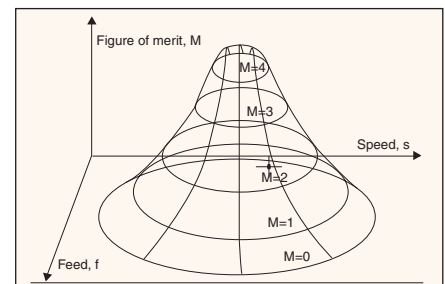

Figure 3: Typical merit function of an ACO system

- Operators may sometimes use feed override in order to earn more incentive, which may result in poor quality parts and tool breakage. This will be prevented when AC is used
- In spite of AC being an effective technique to improve the productivity of the CNC system and safety of the machining process, it could not become the default feature of the CNC controller till recently, due to the following reasons:
- Sensors are costly
 - Fixing the sensor close to the cutting zone is preferable, but it is very difficult. For instance, it is not practical to fix strain gauges on the cutter, since it has to be changed very often during the course of machining
 - The sensors do not have adequate robustness to work in adverse conditions in the workspace

Cutting zone parameter	Sensor
Cutting force/torque/deflection	Strain gauge
Spindle torque/power	No explicit sensor; spindle motor current is used
Vibration	Strain gauge
Chatter	Accelerometer
Online sensing of tool breakage	Strain gauge
In-situ sensing of tool breakage	Air gauge, optical sensing
Broken tooth/ chipping off of cutting edge/built-up edge formation	Accelerometer, spindle motor current
Air gap	No explicit sensor; spindle motor current is used
Improper pallet location	Air gauge
Threshold temperature	Bimetallic strip
Temperature	Thermocouple
In-situ dimensional measurement	Video camera, optical sensing, air gauge, touch probe

ACC	ACO
Generally one cutting zone parameter is monitored	More than one cutting zone parameters are monitored
Cutting speed and feed rate are chosen to maintain the cutting zone parameter at the desired threshold value	Cutting speed and feed rate are chosen to maximise a complex merit function
Computationally simple	Complex computation involving advanced techniques such as ANN
Simple and cheap; hence popular yet popular	Elaborate and costly; still evolving - not

- Each CNC machine requires one AC
- Optimisation is done for every part being produced
- The computing power required to calculate optimal cutting parameters is high, more so in the case of ACO
- Retrofitment by third party is difficult

Offline adaptive control

Among all the variations in the cutting conditions discussed earlier, variation in stock along the tool path is the most predominant. Variation in stock in adaptive CNC systems is sensed by measuring spindle motor current or by using an explicit sensor such as a strain gauge. Interestingly, the source of these stock variations is the NC programme itself. Thus, it can be predicted by analysing the geometry of the process, rather than using the sensors. In other words, ACC for variation in stock can be implemented offline using software. This method of optimising the NC programmes using a software is known as 'Offline adaptive control'. The readers may recall our article in the last issue of this magazine on Virtual Machining (VM) in which we had mentioned its two major applications as NC verification and NC optimisation. Offline AC is the latter.

Two types of optimisation of NC programmes are possible, viz, optimisation of path and optimisation of cutting parameters. For instance, a pocket can be machined using direction parallel (ie, zig-zag) or contour parallel (spiral) paths (Figure 5). Direction parallel path is simple to calculate and has favourable dynamics of machining since the number of direction changes is less, but it has more variations in the stock dimensions along the tool path.

On the other hand, contour parallel path is more complex to calculate and has unfavourable dynamics of machining since the direction changes continuously but it

has uniform stock along the tool path. One can choose optimally between these two types of paths by considering their advantages and limitations. Similarly, parameters such as step-over increment in area clearance, scallop height, cutter geometry, etc, need to be decided optimally. Decisions of this nature belong to optimisation of path. Optimisation of path has to be performed at the time of NC path generation and hence an adaptive controller - be it online or offline - cannot handle this. Thus, AC aims at only optimising the cutting parameters.

Relative hardness and interfering relative motion between tool and work-piece are essential for material removal. The energy required for material removal is transferred to the work-piece through the application of cutting forces by the tool. These cutting forces are transmitted through the contact geometry between the tool and work-piece. Therefore, the cutting forces at any instant of time can be predicted from the contact geometry between the tool and work-piece and their relative velocity known as cutting velocity (v in mm/min). Two other factors that significantly influence the cutting forces are tool geometry and material combination of tool and work-piece. If these four factors are known, cutting forces

& torque can be predicted. Hence, the maximum stress on the tool, which is the resultant of torsion & bending loading, can be obtained.

Alternately, one can calculate the cutting parameters such that the maximum stress in the tool is just below the permissible value. When stock varies along the tool path, it changes the contact geometry. Virtual Machining (VM) software can calculate this contact geometry at any instant of time; hence we can calculate optimal cutting parameters for each tool path without sensors.

Offline AC using VM has two modules, viz, geometric modelling module and mechanistic modeling module. The geometric modeling module calculates the contact geometry at any given time and passes it onto the mechanistic modelling module. The mechanistic modelling module analyses the contact geometry, along with other conditions to arrive at the optimal cutting parameters.

The relation between tool life ' t ' (in minutes) and cutting velocity ' v ' is $vt^n=c$, where the index ' n ' depends on the cutting tool material and ' c ' depends on the other cutting conditions including the properties of the work-piece material. This is an age-old and still valid formula proposed by F W Taylor. Development of high-speed steel and introduction of an incentive scheme are some of his many contributions, which won him the title 'Father of scientific management'. From this formula, it is very clear that tool life is very sensitive to changes in cutting velocity and it should be as low as possible. However, lower the cutting velocity, less is the production. Therefore, there exists a cutting velocity v_{opt} for any tool-work-piece combination that provides an optimal tool life t_{opt} taking into account the economics of

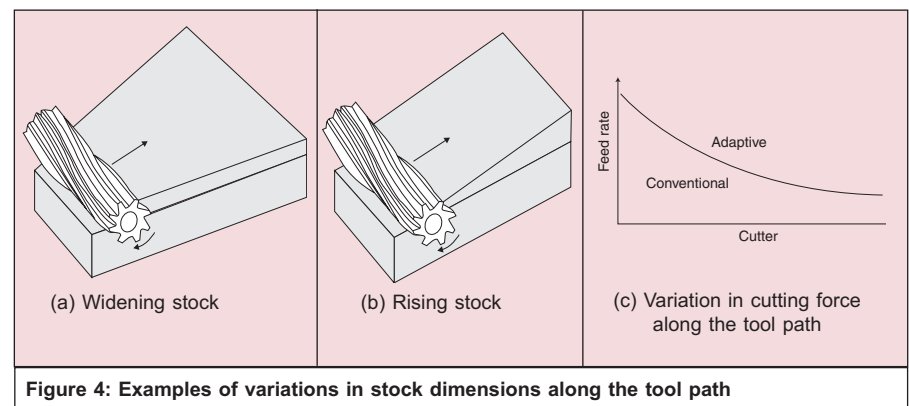

Figure 4: Examples of variations in stock dimensions along the tool path

machining. These values for various tool-work-piece combinations are available in the form of machinability data and slide rules. Some CAM packages have incorporated these databases.

In the case of turning where non-rotating tool is used, feed or longitudinal motion is related to the depth of cut or chip thickness, transverse motion is related to the width of cut and the spindle speed alone is related to the cutting velocity ' v '. Therefore, $v=2\pi rs/60$ in turning, where ' r ' is the distance of the tool tip from the spindle axis. Most CNC lathes automatically adjust the spindle speed when the tool moves along transverse direction so as to maintain optimal cutting velocity. Therefore, only feed motions need optimisation in turning.

As milling uses rotary tools of various kinds and it involves motions of up to five simultaneous axes, it is more complex. For the sake of simplicity, cutting velocity in milling is taken as $v=2\pi rs/60$, where ' r ' is the radius of the tool. The actual cutting velocity in milling is more than this since this formula does not account for the feed motions along the various axes, ie, feed rate ' f '.

Furthermore, the point of contact may keep shifting from the tip of the tool to the extreme in the case of 3D surface machining with ball/ bull nose end mills; therefore, the effective radius of the cutter may vary from 0 to r (Figure 6). In principle, higher spindle speed gives better finish but increases tool wear. Higher feed rate is productive but decreases tool life. The economically optimal tool life for milling is given empirically as $vt^n f^a d^h = k$, where the indices ' a ' and ' h ' also depend on the cutting tool material, ' d ' is the depth of cut and ' k ' depends on the other cutting conditions including the properties of the work-piece material.

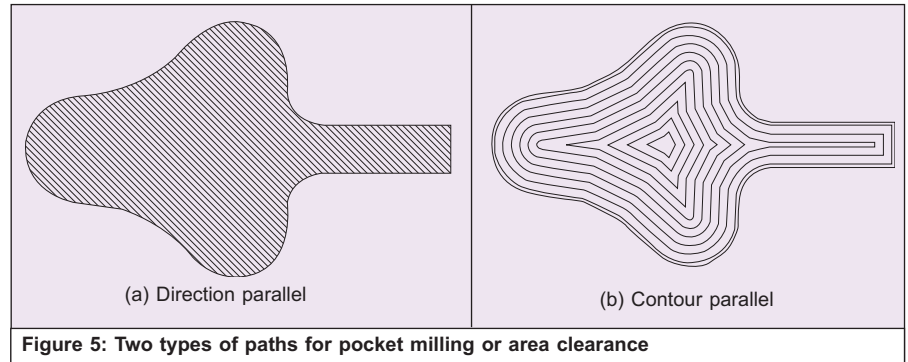

Figure 5: Two types of paths for pocket milling or area clearance

Normally, cutting parameters are specified in the beginning of the NC programmes and these values are same for hundreds of motions. This is illustrated in Figure 7a, where the first and last motions are rapid motions as they approach and retract. The intermediate three motions have a constant feed rate of 400 mm/min. One possibility is to calculate the optimal feed rate for the worst case of each NC block. This is shown in Figure 7b. An alternate approach will be to segment each motion into small motions of an appropriate length called sampling interval. For each of the sampling intervals, optimal feed rate can be calculated as shown in Figure 7c. In the former method, the size of the NC programme remains the same, but the reduction in machining time is not substantial as optimality prevails only for a short duration of each motion.

On the other hand, the reduction in machining time is substantial in the latter method. Although segmentation increases the size of the NC programme, it is not an issue at all with the high memory of modern CNC machines and DNC interfaces. Sampling interval is used both in online and offline AC, in the former it will be specified in time unit and in the latter in length unit. Shorter the sampling interval better is the optimisation; however, its lower bound is limited by the time constant of the AC system, which depends on its inertia and computing speed.

Segmentation-based optimisation is further illustrated in Figure 8 for a motion. Figures 8a and 8b show the tool in end positions. Figure 8c shows the volume of the material removed by this block. Figure 8d shows the contact geometries at different sampling intervals.

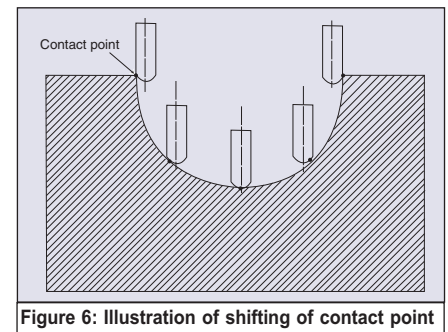

Figure 6: Illustration of shifting of contact point

Empirical implementation of offline adaptive control

The above concepts of Offline AC have been empirically implemented in most of the VM systems. One such popular package is VeriCUT, which has a module called OptiPath for Offline AC. OptiPath emulates ACC as it aims at maintaining a constant MRR.

OptiPath has provision to store machinability databases in a user-friendly manner numerically as well as in the form of graphs. The information about the cut width, cut depth, angle (up/down), percentage of cutter buried in material, cutter type, material type, cutter wear,

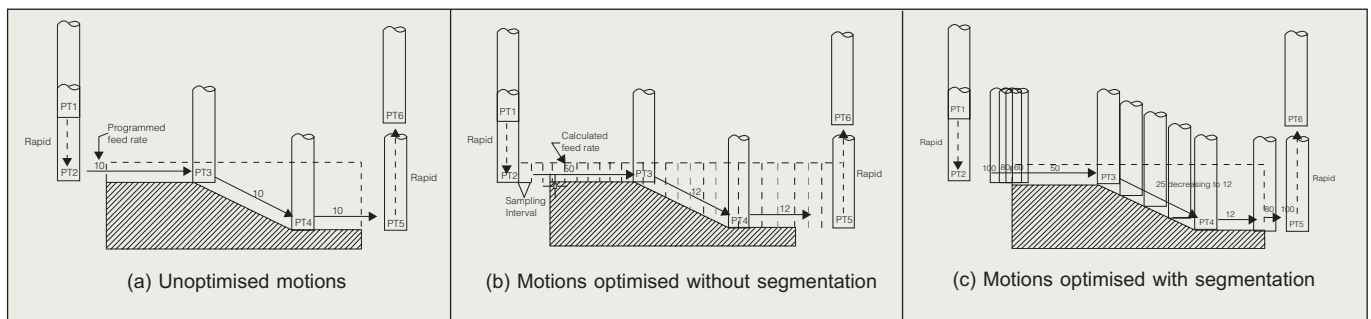

Figure 7: Offline optimisation to maintain constant MRR

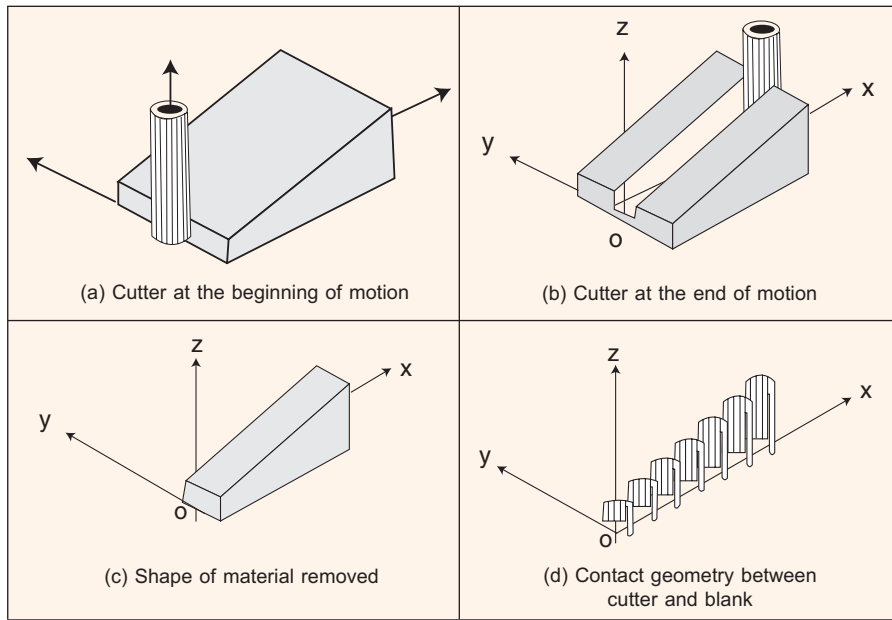

Figure 8: Principle of offline adaptive control

horsepower, fixture and clamp rigidity, etc. can be stored in these databases. The influences of depth of cut, width of cut and angle of tool path on feed rate form the three most important databases of OptiPath. Intuitively, we know that the feed rate has to decrease if the depth of cut or width of cut increases (Figure 9a and 9b).

In an end mill, the side cutting edges have better cutting efficiency than the bottom cutting edges. When it moves horizontally or uphill, its side cutting edges only perform cutting. However, when it moves downhill, its bottom cutting edges come into the picture and hence feed rate should be reduced (Figure 9c). These intuitive feelings can be formalised in the form of graphs in VeriCUT as shown in Figure 9d for each tool. Figure 9a gives feed rate (in mm/min) vs depth of cut. Figure 9b gives the width of cut (as a percentage of tool diameter) vs multiplication factor for width correction. This factor is $\geq 100\%$. Figure 9c gives the cut angle or direction of motion with respect to horizontal (in degree) vs multiplication factor for cut angle correction. This factor is $\leq 100\%$. The range of cut angle is $[0, 90]$ for downhill motion and $[0, -90]$ for uphill motion. Users can create these databases based on their experience or experimental data. As OptiPath knows at any instant the contact geometry and direction of tool, it calculates the optimal spindle

speed and feed rate as follows:

- Draw a line parallel to the direction of the tool path tangent to the tool profile. The distance of the contact point between this line and the tool profile from the axis of the tool is the effective radius r_{eff} of the tool. The shifting of this contact point while machining a spherical cavity with a ball end mill is illustrated in Figure 6. The spindle speed is obtained from this radius using the formula $s=60v_{opt}/(2\pi r_{eff})$
- Calculate maximum depth of cut from the contact geometry. Corresponding to

this depth of cut, read the feed rate from the database of the currently used cutter (Figure 9a). This feed rate corresponds to full plunge of the tool into the work-piece, ie, width of cut is equal to the cutter diameter

- Calculate maximum width of cut from the contact geometry. Corresponding to the ratio of this width to tool diameter, read the width correction factor. Multiply the feed rate by this factor (Figure 9b). Note that this factor always increases the feed rate
- Calculate the angle of the current tool path with respect to the horizontal plane. Corresponding to this cut angle, read the angle correction factor. Multiply the feed rate by this factor (Figure 9c). Note that this factor always decreases the feed rate

VeriCUT along with OptiPath was successfully implemented and tested at DaimlerChrysler AG, Sindelfingen, a few years ago. Moreover, OptiPath claims to cut down machining time by as much as 50% or more. However, a fair amount of customisation is required before it can be deployed for regular use. The major part of customisation goes to the creation of the above databases for various tools used in the shop. Since thousands of motions have to be optimised, the procedure has been highly simplified to gain speed. The problems associated with this simplification are:

- The accuracy of optimisation depends on the machinability data input by the user

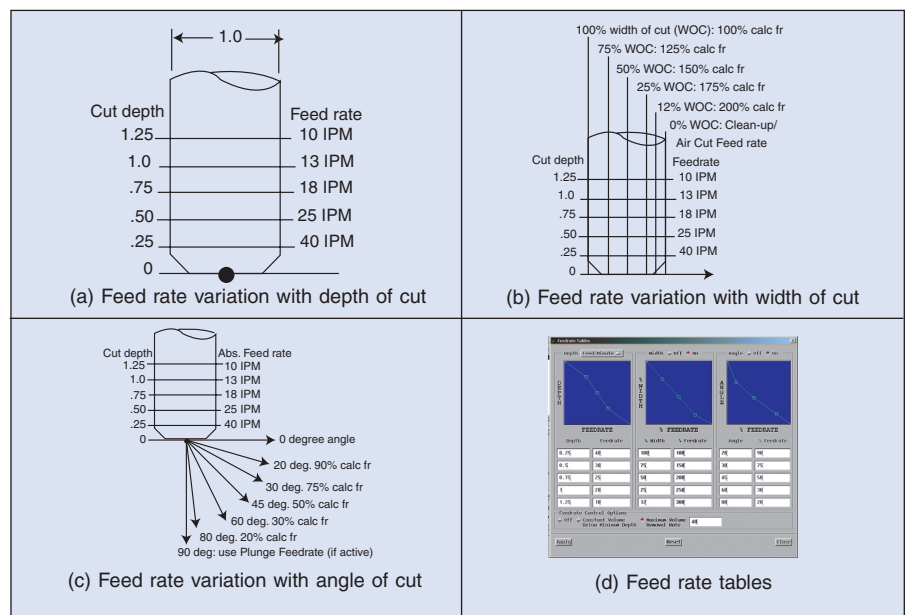

Figure 9: Machinability databases in VeriCUT

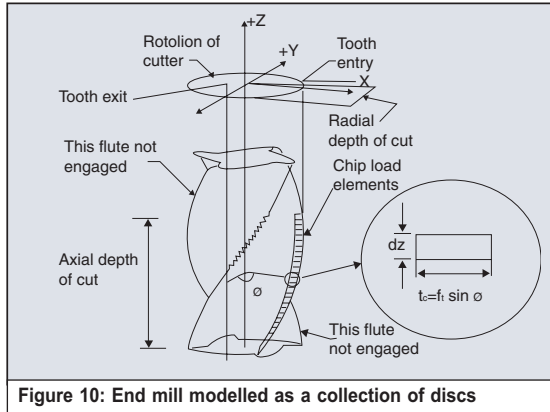

Figure 10: End mill modelled as a collection of discs

- This database has to be created for every new material-cutter combination
- Cutter is almost a solid cylinder for OptiPath. Details such as number of flutes and machining by ball/ bull nose ends are handled only by the correction factors
- Depth of cut and width of cut used in OptiPath are maximum values and hence the feed rate it calculates is slightly conservative

More and more researchers including the authors are working towards a more accurate analysis to obtain the optimal cutting parameters from the contact geometry. According to our analysis, the cutter is

considered as an aggregation of discs as shown in Figure 10. Each disc is rotationally offset slightly with respect to the previous one depending on the helix of the flute. Each of these discs will have parts of the helical cutting edges that can be considered to cut the material orthogonally. The forces experienced by these tiny cutting edges of all discs can be vectorially summed up to get the cutting forces. If the limiting cutting forces or stresses are

known, the corresponding optimal values of cutting parameters can be determined. However, this approach is computationally more intensive.

Conclusion

When CNC is introduced in machining, idle time of setting up the fixtures, indexing, tool changes, etc, are reduced. When AC is introduced in CNC machining, the machining time is substantially reduced. However, AC is too expensive and specific to a machine. Offline AC also does the same economically and can generate output acceptable to any CNC machine. Offline AC is a proactive system as compared to the

reactive online AC. Variation in stock along tool path is predominant and offline AC efficiently handles this situation with the help of VM. Virtual machining packages such as VeriCUT cut down machining time by as much as 50% or more.

Material removal is less than 5% in castings, about 30-40% in dies & moulds and as much as 70% in aerospace parts. Therefore, VM can drastically reduce NC programming time and machining time of dies, moulds and aerospace parts. However, VM has not yet become an integral part of the process cycle in these industries. Presently, VM is done after cutter path generation and hence offline AC cannot offer path optimisation. When VM eventually becomes the default visualisation mode in CAM packages, optimisation of path as well as cutting parameters will take place. ♦

Dr K P Karunakaran is an Associate Professor in the Mechanical Engineering Department of IIT Bombay. He is an Humboldt Fellow having research interests in RP&T, CNC, automation and computer graphics. E-mail: karuna@iitb.ac.in
R Shringi and Amit Kumar Singh are Research Scholars at IIT Bombay.