

Joining Processes



ME 206: Manufacturing Processes I
Instructor: Ramesh Singh; Notes by Prof. S.N. Melkote/Prof.
Ramesh Singh

Welding Processes

- Welding: permanent joining of two materials, usually metals, by *coalescence*
- *Coalescence* results in atoms of the materials being joined to form common crystal structures
- *Coalescence* induced by a combination of temperature, pressure and metallurgical conditions

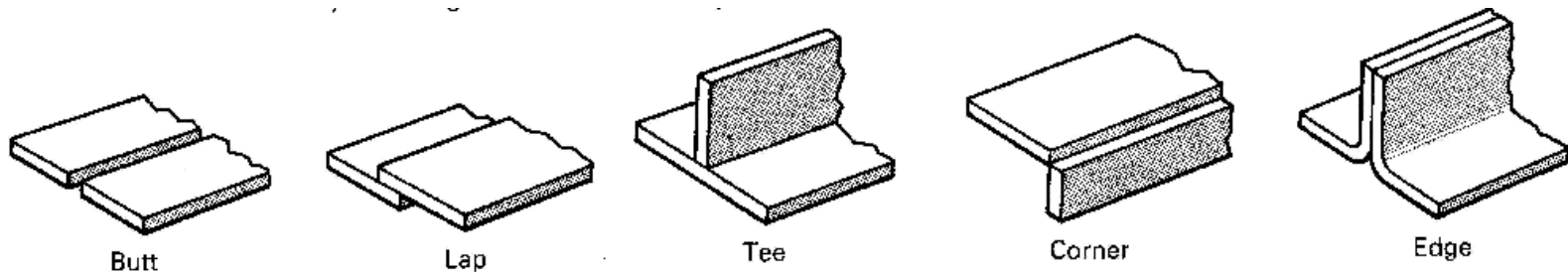

Welding Processes

- High quality weld requires:
 - Source of heat and/or pressure
 - Means to protect/clean metals to be joined
 - Methods to avoid detrimental metallurgical changes

<http://www.youtube.com/watch?v=ROcbeamGhJ0>



Classification of Welding Processes

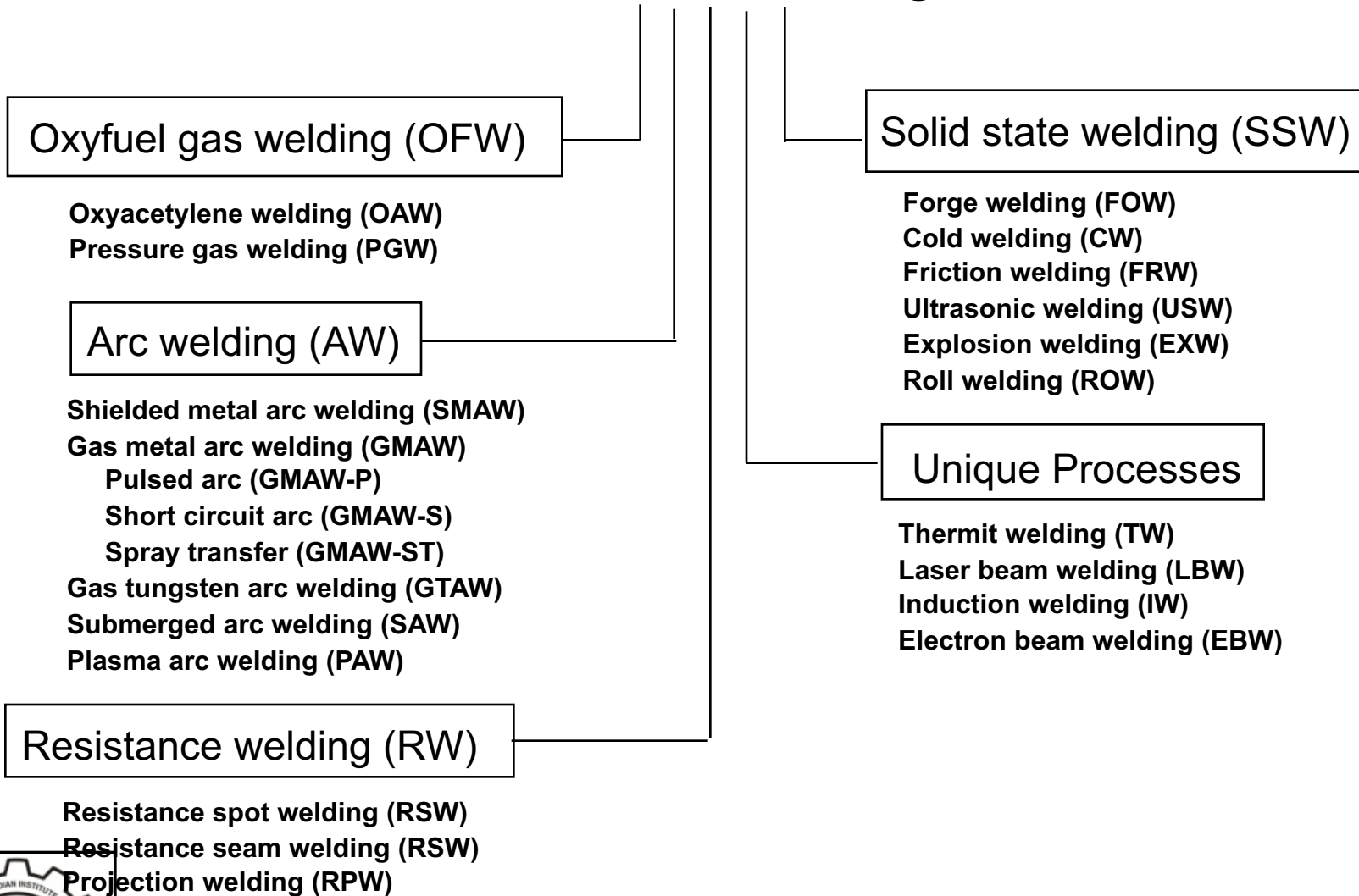

Types of Welds and Joints

Types of Fusion welds

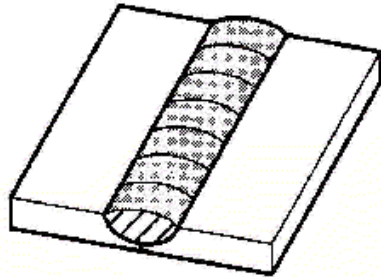

Bead weld
(or surfacing weld)

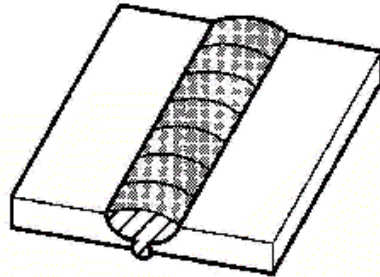

Groove weld

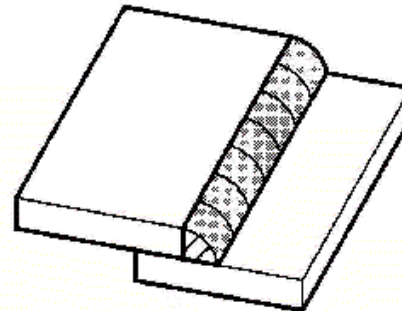

Fillet weld

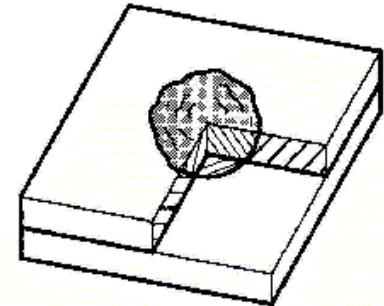

Plug weld

Types of joints



Butt



Lap

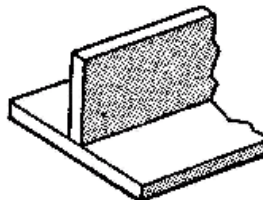

Tee

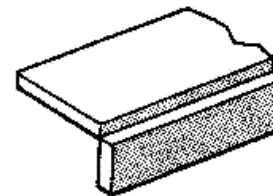

Corner

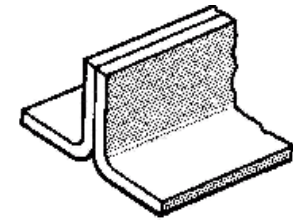

Edge



Examples of Welded Joints

Butt joints



Single-pass square-groove butt joint

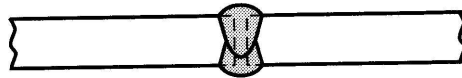

Double-pass square-groove butt joint

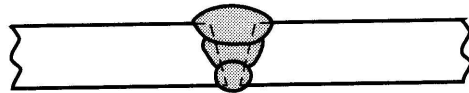

Single V-groove butt joint

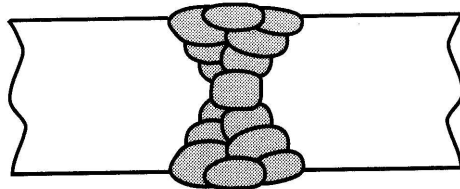

Double V-groove butt joint

T joints

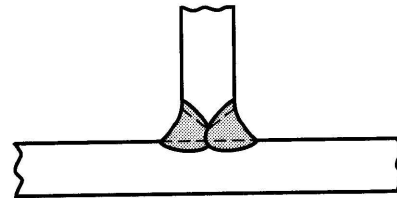

Double bevel-groove T joint

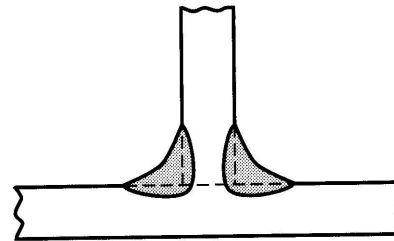

Two-fillet T joint

Corner joints

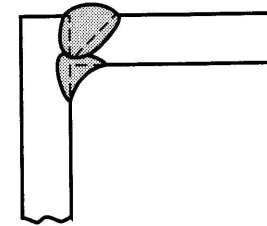

Single bevel-groove corner joint

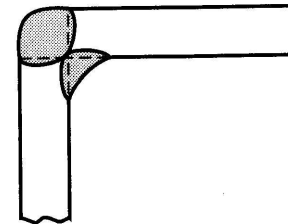

Two fillet corner joint



Typical Weld Microstructure

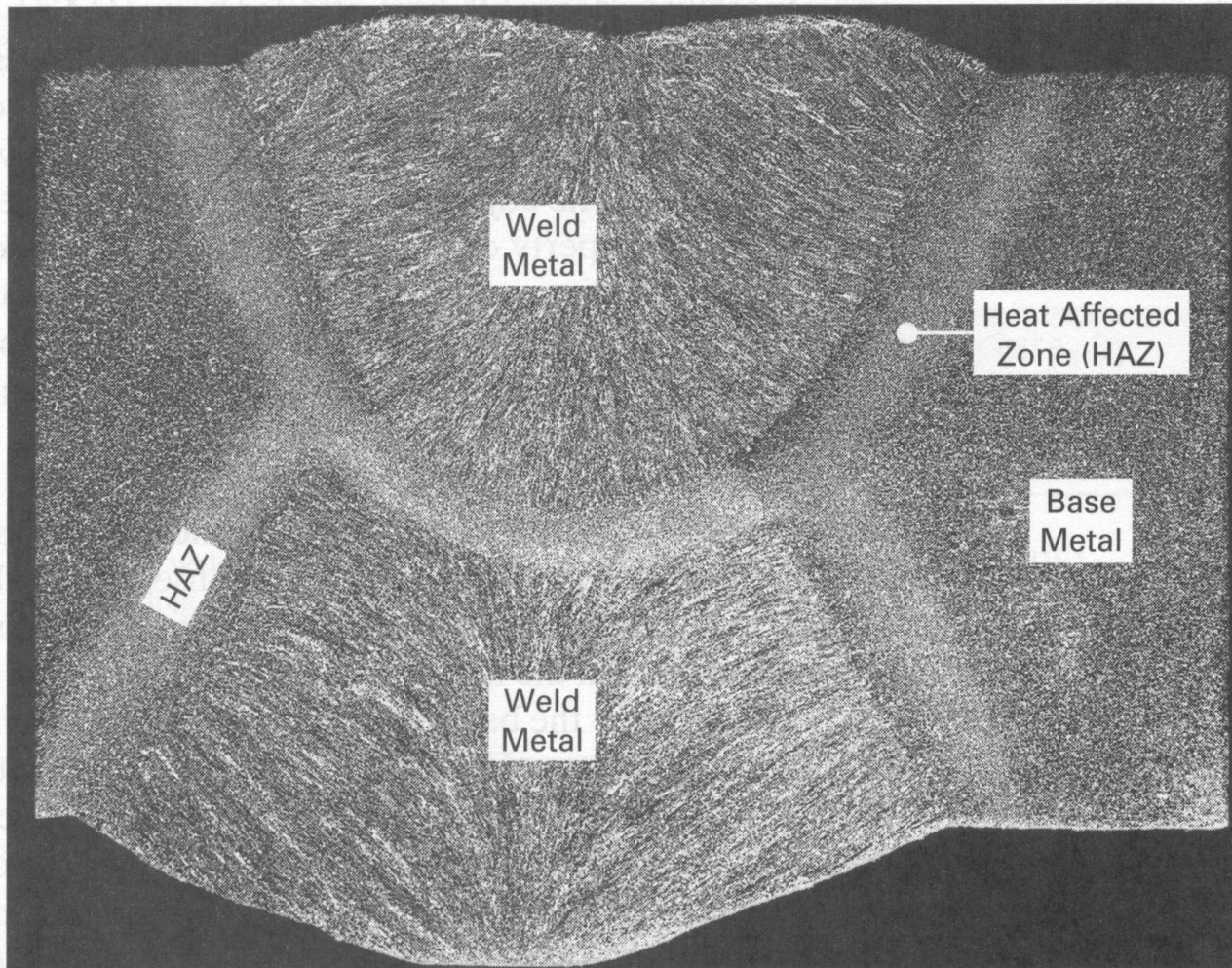

Mode of Metal Transfer

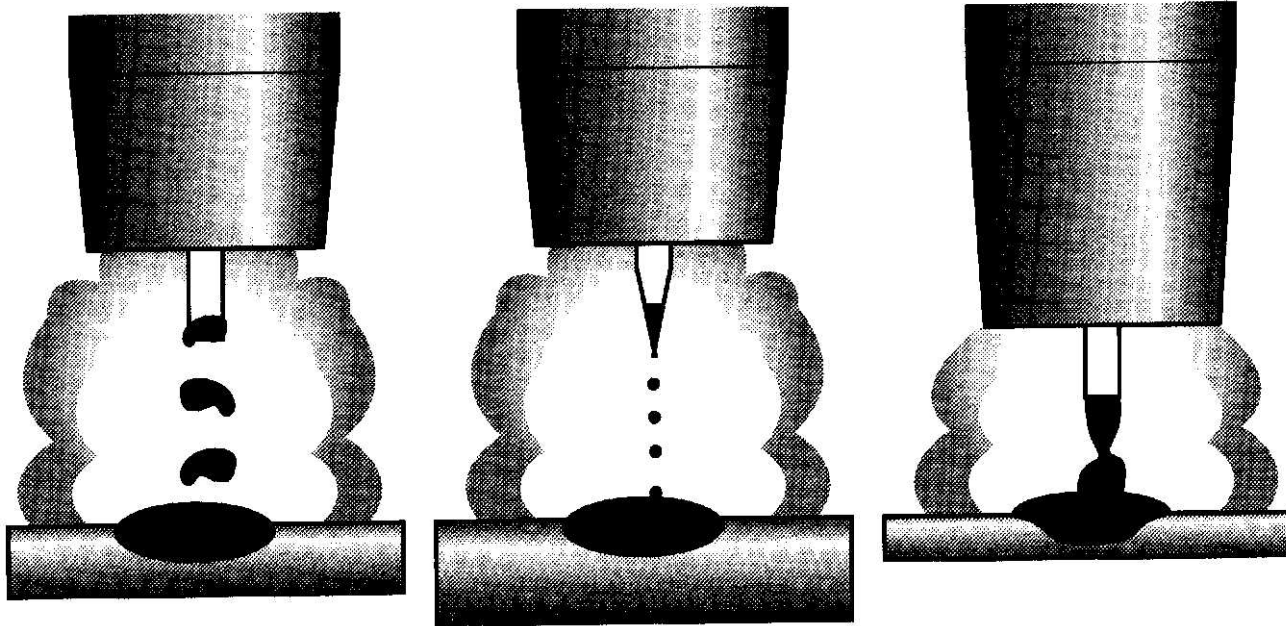

Globular

Spray

Short circuit



Welding Defects

- Heat affected zone (HAZ)
- Residual stresses: thermally-induced
- Welding distortion

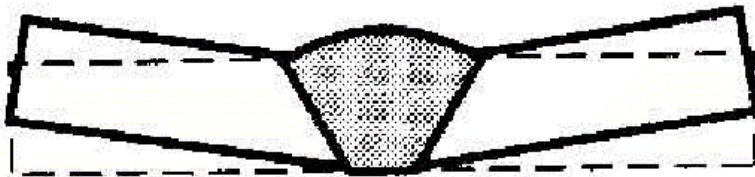

Distorted V-groove butt weld

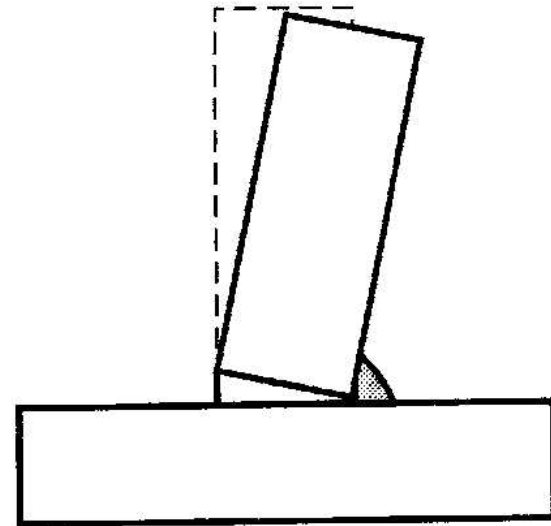

Distorted fillet welded T-joint



Welding Defects

- Residual stresses: thermally-induced

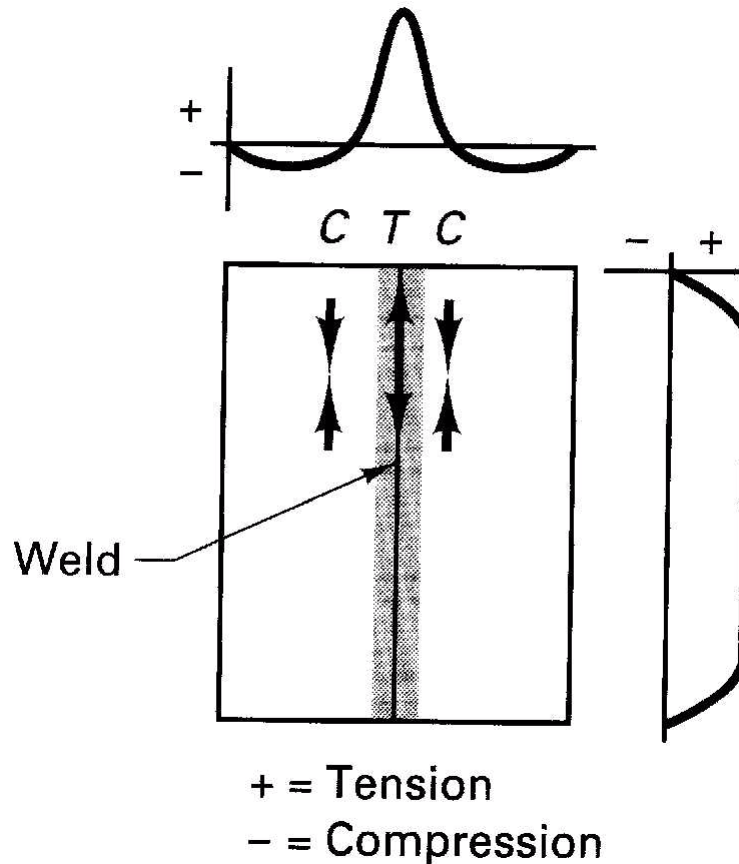

Joining Variations

- **Fastening:** materials are joined together using fasteners (e.g., screws, nails, nuts, bolts)
 - Advantages: any shape or material; can be disassembled; often the least expensive method for volume production
 - Disadvantages: do not develop the full strength of the base material; do not produce hermetic seals; fasteners are extra parts; need to drill holes.
- **True bonding:** formation of a bond
 - The perfect joint is indistinguishable from the material surrounding it (diffusion bonding).
 - Any two solids will bond if surfaces are brought into intimate contact. Two inhibiting factors: 1) surface contamination (in nanoseconds); 2) do not mate perfectly (true contact area <10%).



Joining Variations (Cont')

- **True bonding**

- Welding using interfacial shear (cold welding): ultrasonic welding; friction welding
- Adhesive bonding: viscous fluid fills hills & valleys; bond created by surface tension forces or mechanical interlocking; weaker than interatomic bonds; best for joining sheets, fibers
- Diffusion bonding: materials held together under high pressure at elevated temperature to increase contact area (surface contaminants must be soluble)
- Fusion welding: materials are melted and bonded together by means of heat (chemical or electrical).



Fusion Welding

- Heat + filler material = weld
- Types (different heat sources)
 - Flame: oxygen + fuel (oxy-acetylene)
 - Electric arc
 - Resistance
 - Laser beam
 - Electron beam



Oxy-Acetylene Welding



Flames are categorized in terms of their combustion intensity:

$$CI = C_h \cdot C_v$$

CI: W/cm²; C_h: heat content of the gas per unit vol, J/m³; C_v: gas velocity, cm/s



Flame temperatures

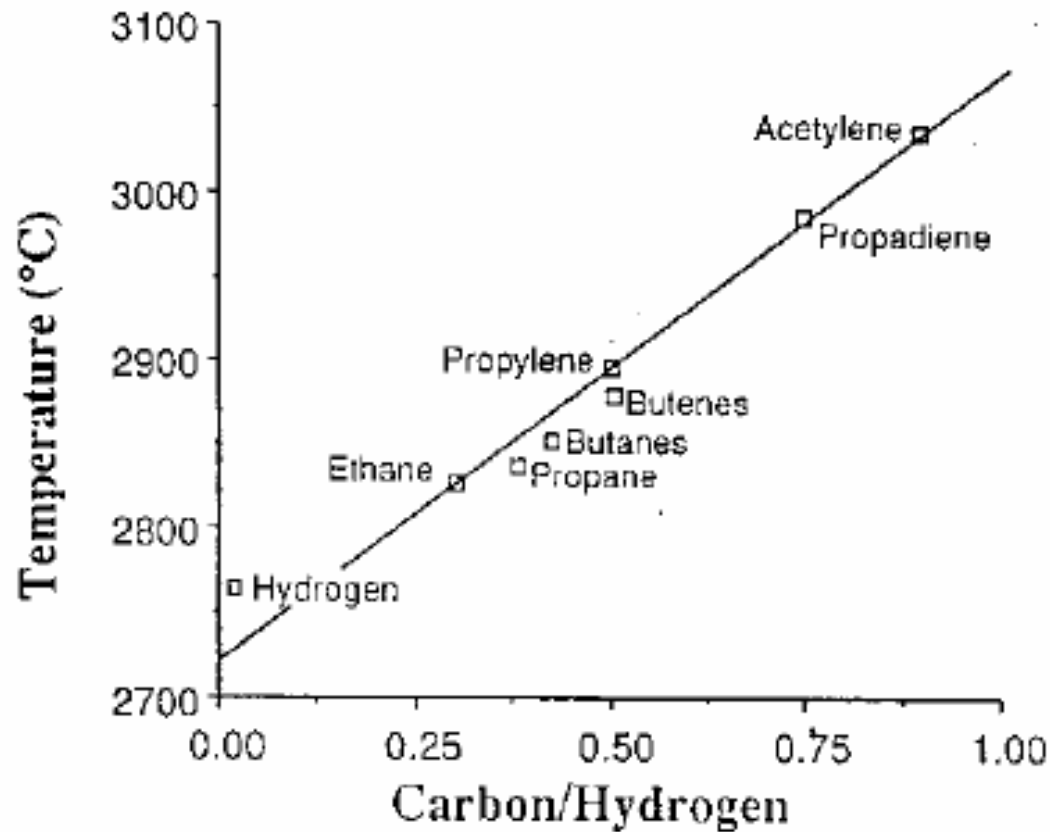

$$CI \propto T^2$$

1000 W/cm²

Classification of temperature of combustion of fuels as a function of the C/H ratio



Arc Welding

- Consumable Electrode
 - Shielded Metal Arc welding (SMAW)
 - Submerged Arc welding (SAW)
 - Gas Metal Arc welding (GMAW)
- Non-consumable Electrode
 - Gas Tungsten Arc welding (GTAW)
 - Plasma Arc Welding (PAW)



Shielded Metal Arc Welding (SMAW)

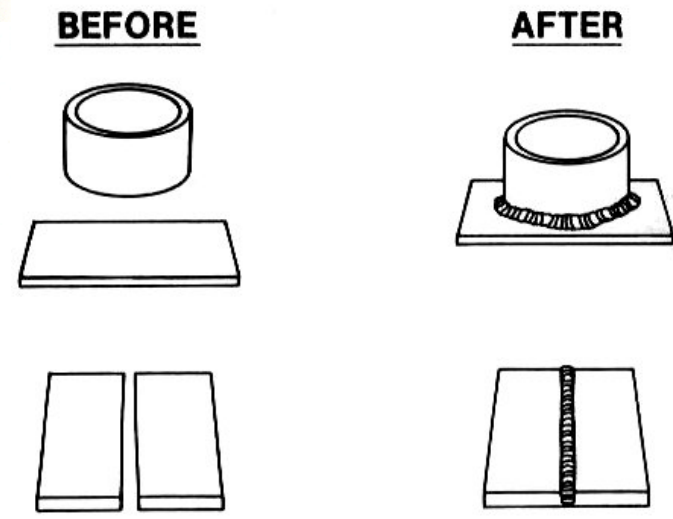
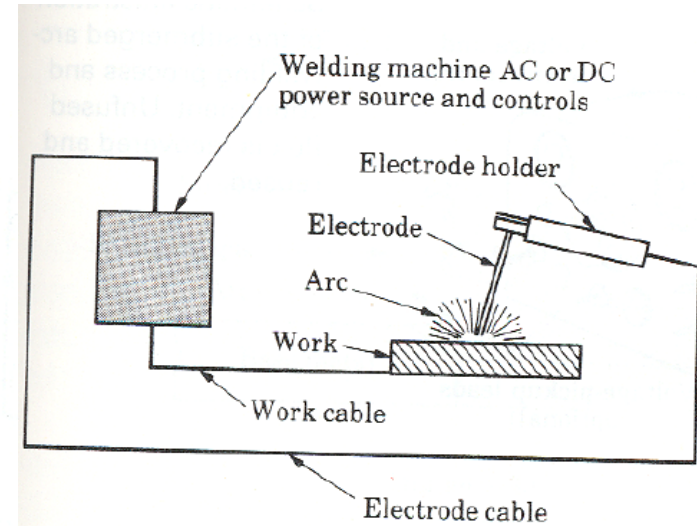
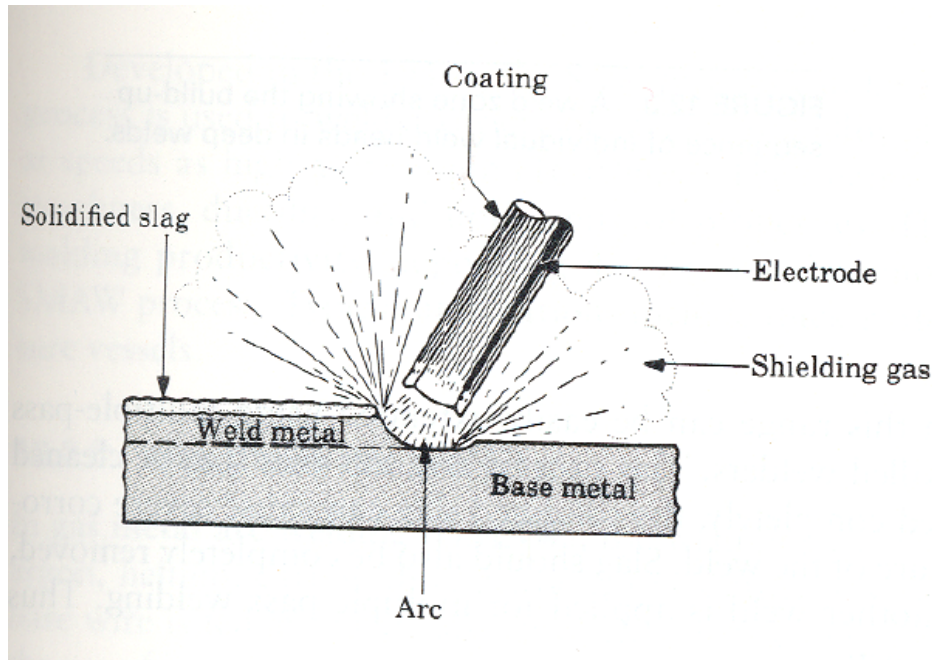

Process Description

- Electrode coating (e.g. cellulose + titania) vaporizes and provides a protective gas shield around arc and weld pool to prevent oxidization
- Electric arc generated by touching the electrode tip against workpiece
- Sufficient distance between workpiece and electrode is required to maintain arc
- Parent material, electrode metal and some material from coating solidify in the weld
- Globular or short circuit mode of metal transfer
- Current ranges from 50 – 300 A
- Power requirement is less than 10 kW



Electrode Coating Functions

- Protective gas shield around arc and pool of molten metal
- Provide ionizing elements to stabilize arc, reduce weld metal spatter, and increase efficiency of deposition
- Act as flux to deoxidize and remove impurities from molten metal
- Provide protective slag coating to collect impurities, prevent oxidation, and slow the cooling of weld metal
- Add additional filler metal
- Add alloying elements
- Influence arc penetration (depth of melting in workpiece)



Process Capabilities

- Weld rates up to 0.2 m/min
- Arc penetration generally < 5 mm
- Minimum sheet thickness = 1.5 mm
- Maximum sheet thickness = 200 mm
- Multiple passes required on sheet thickness ≥ 5 mm (requires slag removal after each pass)
- Commonly welded materials are carbon steels, low alloy steels, stainless steels, Ni alloys and cast iron
- Tolerances ± 1 mm (typical)
- Surface finish is fair to good



SMAW

- Advantages
 - Most versatile of all welding processes (50%)
 - Suitable for site work
 - Tooling costs are low
 - All levels of complexity are possible
 - Economical for low production runs
- Limitations
 - Direct labor costs are high
 - Slag produced at the weld area needs grinding
 - Discontinuous process, frequent electrode changes
 - Heat affected zone is present



Submerged Arc Welding (SAW)

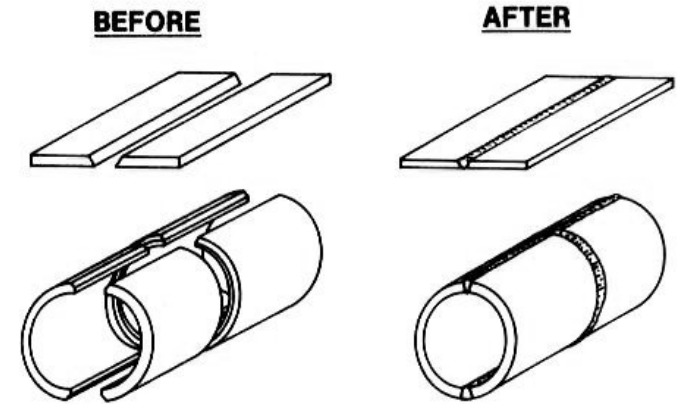
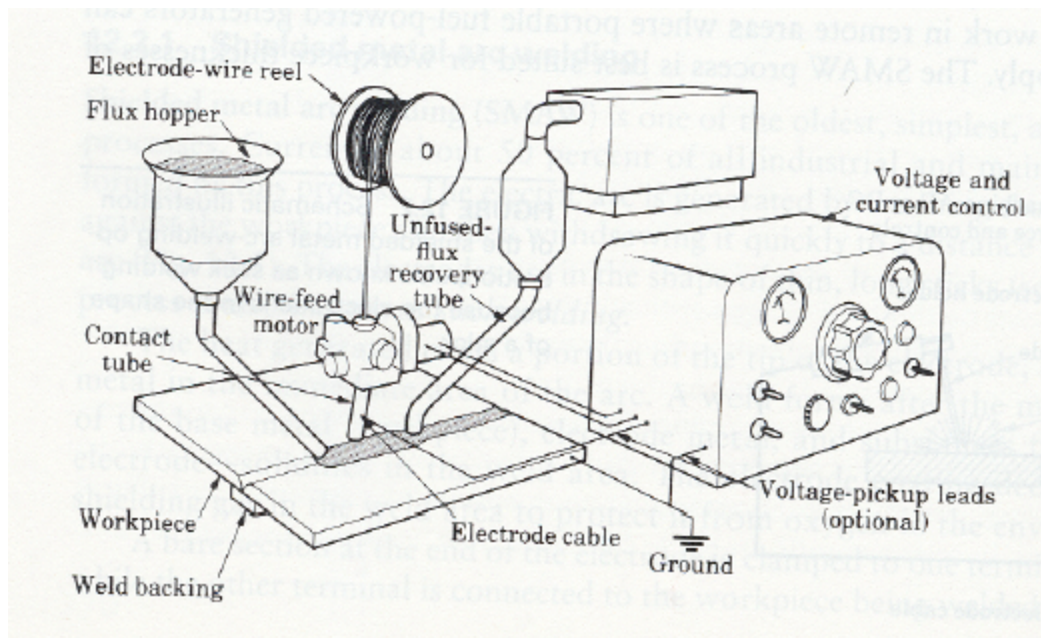

Process Description

- Shielded by gravity fed granular flux, which covers molten material, preventing sparks, spatter and UV radiation
- Electrode is in the shape of wire fed through a tube
- Unused slag is recycled
- Parent metal and wire form the weld pool
- Current ranges from 300 – 2000 A
- Voltage used is 3 phase 440 V
- Can be highly automated
- Heat penetration is deep (up to 25 mm)



Process Capabilities

- Weld rates up to 5 m/min
- Minimum sheet thickness = 5 mm
- Maximum sheet thickness = 300 mm for carbon, stainless and low alloy steels
- Maximum sheet thickness = 20 mm for Ni alloys
- Multiple passes required on sheet thickness ≥ 40 mm
- Well-suited for butt and fillet welds in low carbon steels ($< 0.3\%$ carbon)
- Typical tolerance: ± 2 mm
- Surface finish is good



SAW

- Advantages
 - Self-contained, highly automated with up to 3 welding heads
 - Economic for straight, continuous welding on very thick plates
 - Tooling cost are low to moderate
 - High quality weld with low distortion and high toughness
- Limitations
 - Design complexity is limited
 - Finishing costs are high because of slag removal
 - Flux handling and recycling can be expensive
 - Can alter composition of weld by alloying elements from the electrode
 - Heat affected zone is present



Gas Metal Arc Welding (GMAW)

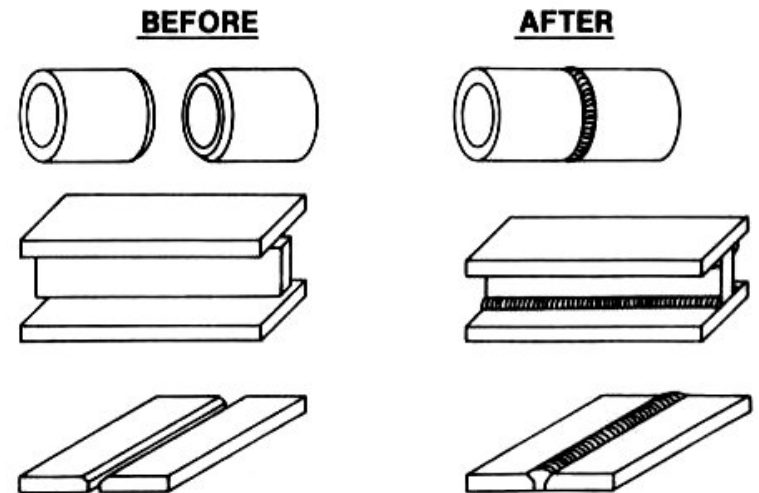
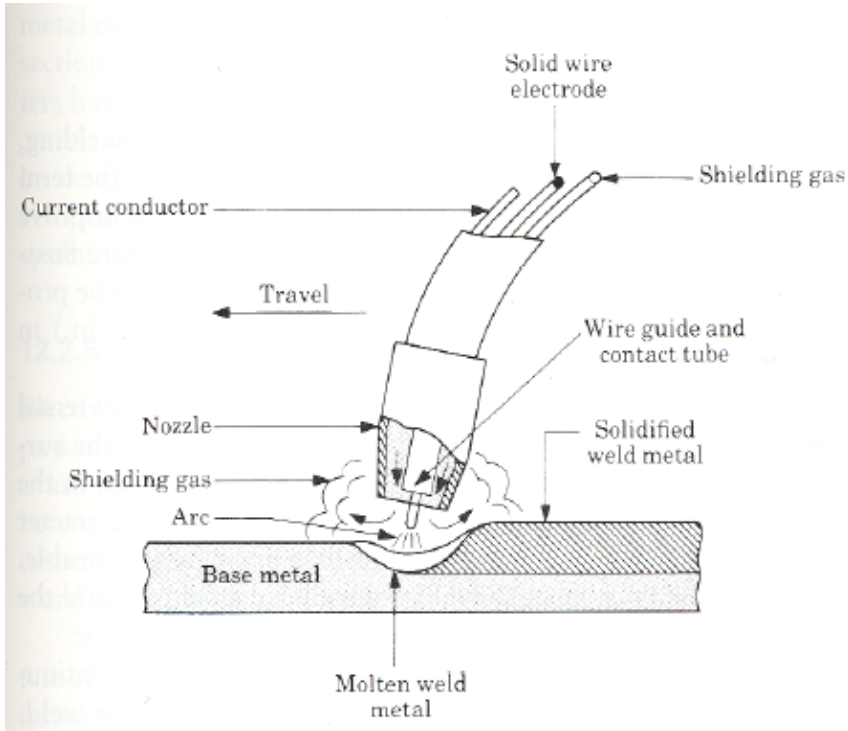

Process Description

- Shielded by external source such as argon, helium, CO₂ and other inert gas
- Wire electrode fed through a nozzle into the weld arc
- Parent metal is melted and wire acts as filler material
- Power required: 2 kW
- Max. arc penetration 6-10 mm
- Can be automated



Process Capabilities

- Weld rates up to 0.5 m/min
- Minimum sheet thickness = 0.5 mm (6 mm for cast iron)
- Maximum sheet thickness = 80 mm for carbon, stainless and low alloy steels, Al, Mg, Ni, Ti alloys and Cu
- Maximum sheet thickness = 6 mm for refractory alloys
- Multiple passes required on sheet thickness ≥ 6 mm
- Typical tolerance: ± 0.5 mm
- Surface finish is good



GMAW

- Advantages
 - All levels of complexity possible
 - High weld deposition rates with continuous operation
 - Well suited to traversing automated and robotic systems
 - Tooling cost are low to moderate
- Limitations
 - Direct labor costs can be high
 - Wire electrode must closely match the composition of the metals being welded
 - Cracking may be experienced when welding high alloy steel
 - Heat affected zone is present



Gas Tungsten Arc Welding (GTAW)

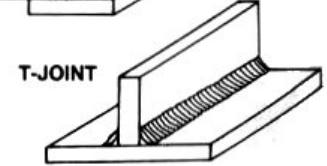
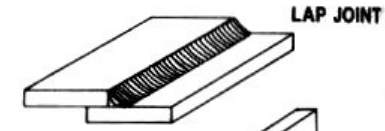
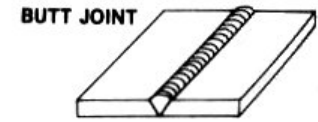
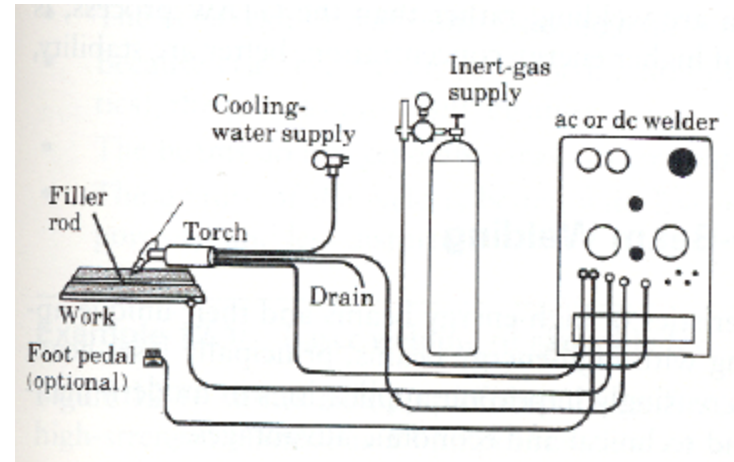
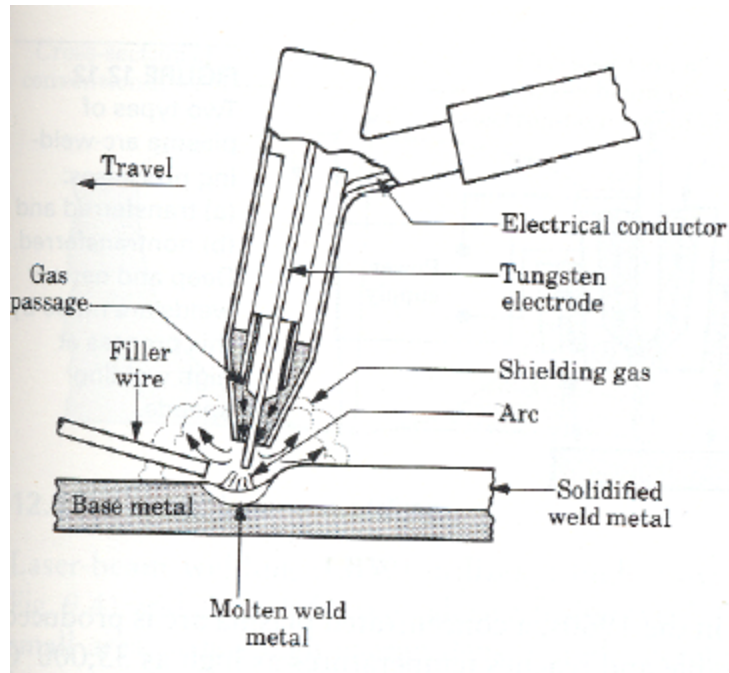

Process Description

- Shielded by external source, such as argon, helium and their mixture
- Tungsten is used as non-consumable electrode
- Filler metal is supplied from filler wire
- Typical current: <200A DC or <500A AC
- Parent metal is melted and wire acts as filler material
- Power required varies from 8 kW to 20 kW
- Max. arc penetration 3 mm
- Can be automated



Process Capabilities

- Weld rates up to 1.5 m/min
- Minimum sheet thickness = 0.1 mm
- Maximum sheet thickness = 6 mm for carbon, stainless and low alloy steels, Mg and Ni alloys
- Maximum sheet thickness = 15 mm Al and Ti alloys
- Maximum sheet thickness = 3 mm for Cu and refractory alloys
- Multiple passes required on sheet thickness ≥ 4 mm
- Typical tolerance: ± 0.5 mm
- Surface finish of weld is excellent



GTAW

- Advantages

- All levels of complexity possible
- Low distortion can be achieved
- Automation suited for continuous weld in same plane and relatively inexpensive if no filler is required
- Economical for low production runs

- Limitations

- Direct labor costs can be high
- Filler wire must closely match the composition of the metals being welded
- Not recommended for site work in wind
- Heat affected zone is present stress relieving may be required



Plasma Arc Welding (PAW)

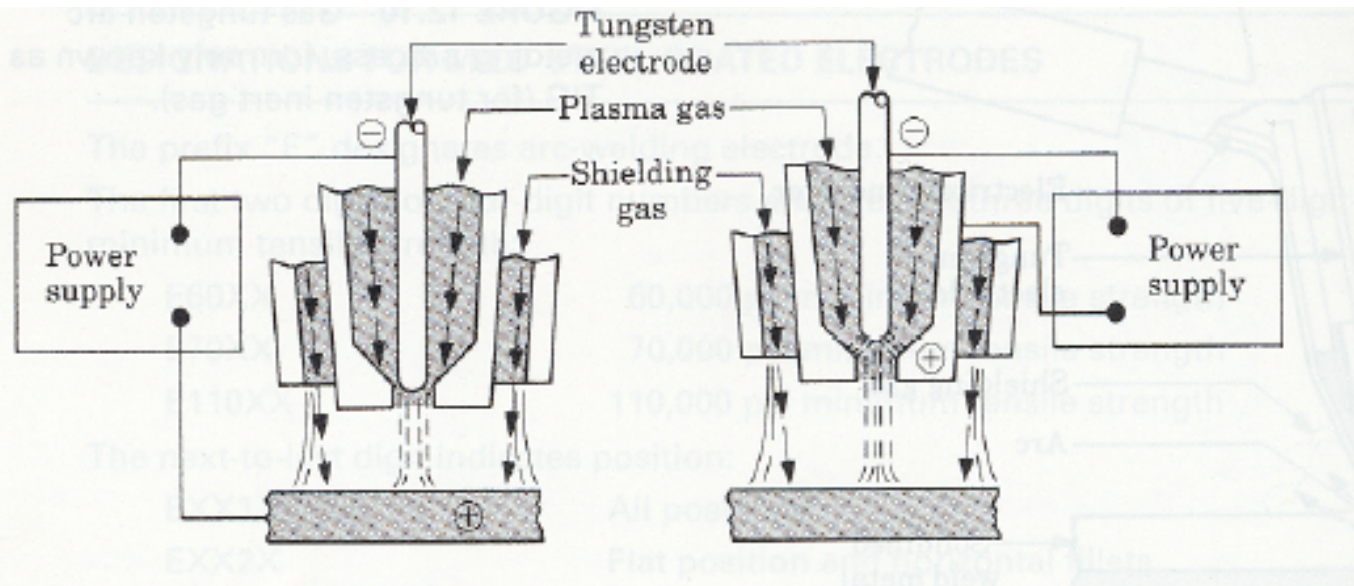

a. Transferred

b. Non-transferred



Process Description

- Shielded by external source, such as argon, helium and their mixture
- Tungsten is used as non-consumable electrode
- Concentrated plasma is produced and aimed at the weld area
- Filler metal wire may be used
- Current can be as high as 100 A
- Temperature can be as high as 33,000°C



Process Capabilities

- Weld rates vary from 0.12 to 1 m/min
- Maximum sheet thickness = 6 mm and 20 mm for Al and Ti alloys
- Wide variety of materials can be welded
- Typical tolerance: ± 0.5 mm
- Surface finish is good



PAW

- Advantages

- Low distortion can be achieved
- Higher energy concentration and better arc stability
- Automation suited for continuous weld in same plane and relatively inexpensive if no filler is required
- Economical for low production runs

- Limitations

- Very High temperatures are encountered
- Filler wire must closely match the composition of the metals being welded
- Not recommended for site work in wind
- heat affected zone is present



Thermal Modeling:

Instantaneous point heat source

The differential equation for the conduction of heat in a stationary medium assuming no convection or radiation, is

$$\frac{\partial^2 T}{\partial x^2} + \frac{\partial^2 T}{\partial y^2} + \frac{\partial^2 T}{\partial z^2} + q = \frac{1}{\alpha} \frac{\partial T}{\partial t}$$

This is satisfied by the solution for infinite body,

$$dT(x, y, z, t) = \frac{\delta q}{\rho C (4\pi\alpha(t-t'))^{3/2}} \exp \left[-\frac{(x-x')^2 + (y-y')^2 + (z-z')^2}{4\alpha(t-t')} \right]$$

gives the temperature rise at position (x, y, z) and time t due to an instantaneous heat source δq applied at position (x', y', z') and time t' ; where δq = instantaneous heat generated, C = sp. heat capacity, α = diffusivity, ρ = Density, t = time, K = thermal conductivity.

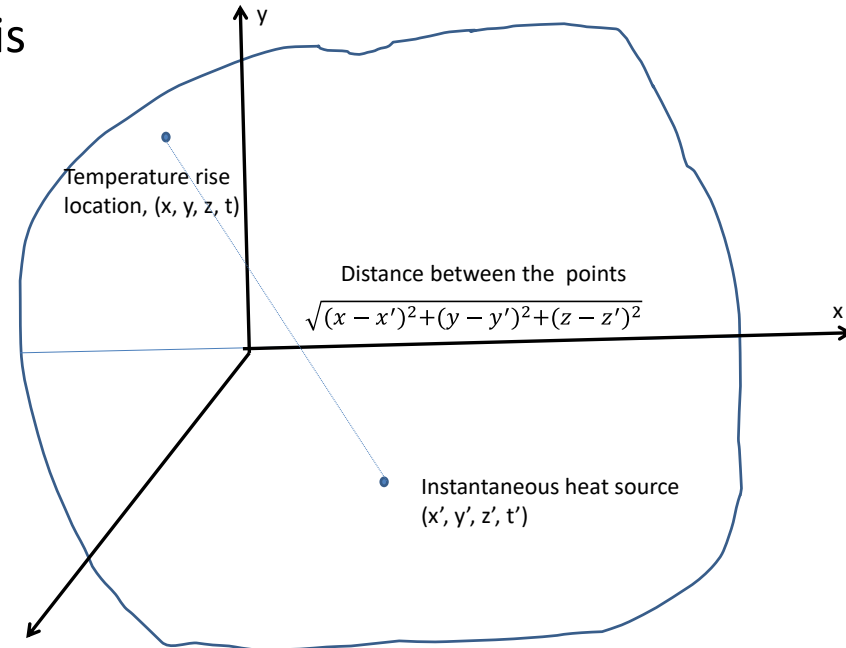

Moving point heat source in semi-infinite body

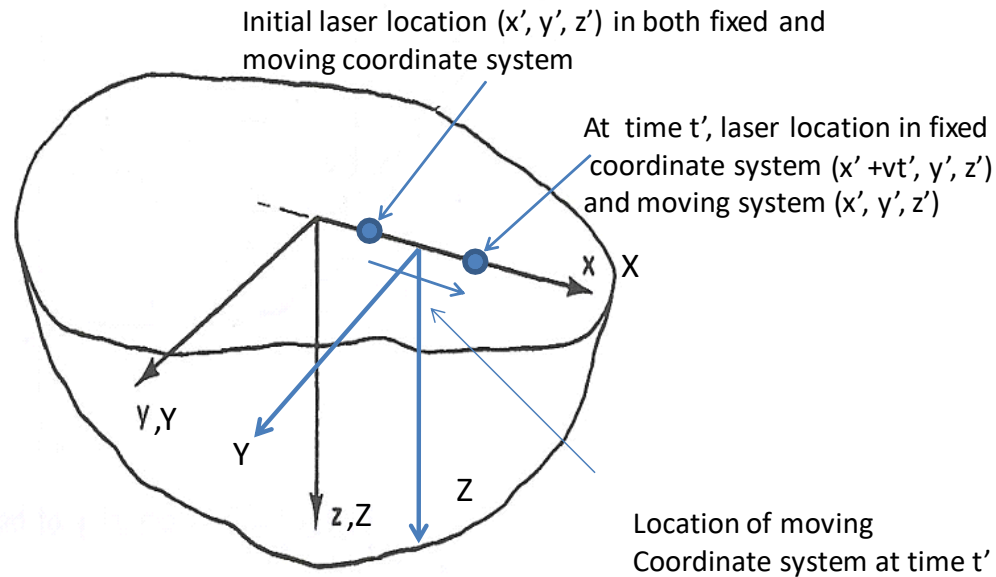

Moving laser source along X-axis in a semi -infinite body

In moving coordinate system:

$$dT(X, Y, Z, t) = \frac{2\delta q}{\rho C (4\pi a(t-t'))^{\frac{3}{2}}} \exp\left[-\frac{(X-x')^2 + (Y-y')^2 + (Z)^2}{4a(t-t')}\right]$$

In fixed coordinate system:

$$dT(x, y, z, t) = \frac{2\delta q}{\rho C (4\pi a(t-t'))^{\frac{3}{2}}} \exp\left[-\frac{(x-vt'-x')^2 + (y-y')^2 + (z)^2}{4a(t-t')}\right]$$

Note that $\delta q = P dt'$



Line heat source in infinite body:

Temperature for the line heat source can be obtained directly by integrating the solution of the point source in the moving coordinate system.

- **line source in moving coordinate:**

Line source parallel to z-axis and passing through point (x', y') in moving system. The temperature obtained by integrating, where C = sp. heat capacity, ρ = Density, K = thermal conductivity. Here Q_l = heat per unit length

For infinite body

$$dT'(X, Y, Z, t) = \frac{\delta q}{\rho C (4\pi a (t - t'))^{\frac{3}{2}}} \exp\left[-\frac{(X - x')^2 + (Y - y')^2 + (Z - z')^2}{4a(t - t')}\right]$$

This point source in moving coordinates can be superposed for infinite line along z,

$$dT'(X, Y, t) = \frac{q_l dt'}{\rho C (4\pi a (t - t'))^{\frac{3}{2}}} \int_{-\infty}^{\infty} \exp\left[-\frac{(X - x')^2 + (Y - y')^2 + (Z - z')^2}{4a(t - t')}\right] dz$$

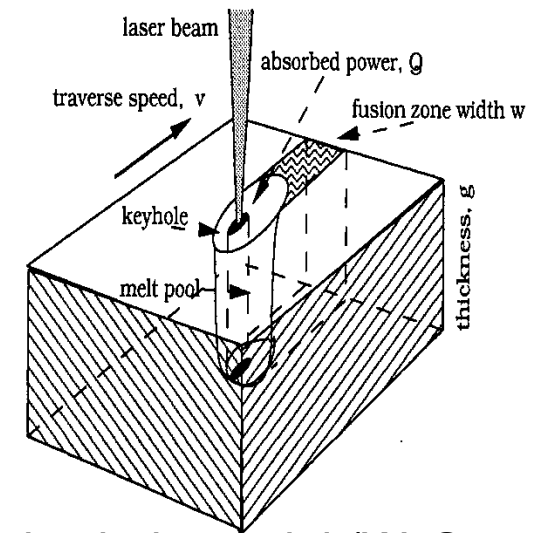

Fig. keyhole model (W. Steen)



Infinite line source

- Integrating in moving coordinate system with respect to spatial variables,

$$dT(X, Y, t) = \frac{q_l dt'}{4\pi k(t - t')} \exp \left[-\frac{(X - x')^2 + (Y - y')^2}{4a(t - t')} \right]$$

- Convert to stationary frame and integrate to time

$$X = x - vt', \quad Y = y \quad \text{and} \quad Z = z$$

$$\begin{aligned} T - T_0(x, y, t) &= \int_{t'=0}^t \frac{q_l dt'}{4\pi k(t - t')} \exp \left[-\frac{(x - vt' - x')^2 + (y - y')^2}{4a(t - t')} \right] \end{aligned}$$

This can be integrated numerically



Moving line heat source

- Using the same concept used in stationary continuous point where the laser (heat source) started at $t' = -\tau$, and at time $\tau=0$ the laser source is at origin ($x'=0$ and $y'=0$). One can get solution at (X, Y) from laser source:

$$T(X, Y, t) = \int_0^t \frac{q_l d\tau}{4\pi k(\tau)} \exp \left[-\frac{(X + v\tau)^2 + Y^2}{4a(\tau)} \right]$$

The steady state solution at $t \rightarrow \infty$,

$$T(X, Y) = \frac{q_l}{2\pi k} e^{-\frac{vX}{2\alpha}} \text{Bessel}K \left(0, \frac{v\sqrt{X^2 + Y^2}}{2\alpha} \right)$$

Bessel function of second kind 0 order

It may be noted that it is a steady-state solution and X, Y are from the laser center



Analysis of Welding

- Motivation

- Martensite formation, especially in HAZ (Heat Affected Zone) surrounding the fusion area, can result in cracks and failure initiation sites
- To calculate the time required to avoid fully martensitic regions in HAZ which is estimated by time required for the weld to cool from 800°C to 500°C, $\tau_{8/5}$



Instantaneous Infinite Line Heat Source

Time dependent equation for heat transfer from a instantaneous line heat source:

$$dT(X, Y, t) = \frac{Q}{4\pi k(t - t')} \exp \left[-\frac{(X - x')^2 + (Y - y')^2}{4a(t - t')} \right]$$

Temperature rise at current time for infinite instantaneous line heat source released at time -t

$$T - T_0 = \frac{Q}{4\pi kt} \exp \left[-\frac{r^2}{4at} \right]$$

where:

T = Metal temperature

k = Thermal conductivity

a = diffusivity

Q = heat/unit length in J/m



Cooling Times

- Time required to avoid fully martensitic regions in HAZ in case of thick welding (more than six passes). The heat transfer equation yields:

$$\tau_{8/5} = \frac{Q}{4\pi k} \left[\frac{1}{(500 - T_0)} - \frac{1}{(800 - T_0)} \right]$$

where:

$\tau_{8/5}$ = Centerline cooling time

T_0 = Base metal ambient temperature ($^{\circ}\text{C}$)

Q = Net heat input per unit length to the weld



Cooling Times

- Time required to avoid fully martensitic regions in HAZ in case of thin plate. The 2-D dimensional heat transfer equation yields:

$$\tau_{8/5} = \frac{(Q/h)^2}{4\pi k\rho C} \left[\left(\frac{1}{500 - T_0} \right)^2 - \left(\frac{1}{800 - T_0} \right)^2 \right]$$

where:

h = Base metal thickness

ρ = Base metal density

C = Specific heat of the base metal



Cooling Times

- Relative thickness parameter, λ , decides whether to use thick or thin plate parameter

$$\lambda = h \sqrt{\frac{\rho C (550 - T_0)}{Q}}$$

$\lambda > 0.75$ implies thick plate and $\lambda < 0.75$ implies thin plate



Power

- Power input per unit length is given by:

$$Q = \eta \frac{VI}{v}$$

where:

v = Welding speed

V = Welding voltage

I = Welding current

η = Weld heat transfer efficiency



Example

Two 12 mm thick alloy steel plates are submerged arc welded together with the following conditions: 25 V , 300 A and an efficiency of 0.9. test weld beads are deposited at speeds of 6, 7, 8, 9 and 10 mm/s and hardness is measured. The hardness is fully martensitic next to fusion zone at 8 mm/s and faster. The ambient temperature is 25⁰C. Estimate the cooling time that results in a fully martensitic zone.

$$\rho = 7.8 \cdot 10^3 \text{ Kg/m}^3$$

$$C = 0.5 \cdot 10^3 \text{ J/Kg K}$$

$$k = 0.04 \cdot 10^3 \text{ W/m K}$$



Solution

Heat input per unit length of the weld:

$$Q = \eta \frac{VI}{v} = 0.9 \frac{25 \times 300}{8 \times 10^{-3}} 844 \times 10^3 J / m$$

Relative plate thickness:

$$\lambda = h \sqrt{\frac{\rho C (550 - T_0)}{Q}} = 12 \times 10^{-3} m \sqrt{\frac{7.8 \times 10^3 Kg / m^3 \times 0.50 \times 10^3 J / Kg^{\circ} C (550 - 25)^{\circ} C}{844 \times 10^3 J / m}}$$

$$= 0.59$$

Implies use of thin sheet formula



Solution

- Applying thin plate formula

$$\begin{aligned}\tau_{8/5} &= \frac{(Q/h)^2}{4\pi k\rho C} \left[\left(\frac{1}{500 - T_0} \right)^2 - \left(\frac{1}{(800 - T_0)} \right)^2 \right] \\ &= \frac{\left(\frac{844 \times 10^3 \text{ J / m}}{12 \times 10^{-3} \text{ m}} \right)^2}{4\pi(0.04 \times 10^3 \text{ J / s.m.}^0 \text{ C})(7.8 \times 10^3 \text{ Kg / m}^3 \times 0.50 \times 10^3 \text{ J / Kg.}^0 \text{ C})} \left[\left(\frac{1}{480} \right)^2 - \left(\frac{1}{780} \right)^2 \right] = 6.7 \text{ s}\end{aligned}$$





Algorithm for Moving Heat Source Modeling & Metallo-thermomechanical Analysis in Abaqus

Ashby & Esterling, 1984
Ramesh & Melkote, 2008

AC1: Austenization start temperature of substrate
AC3: Austenization end temperature of substrate
NT: Nodal temperature

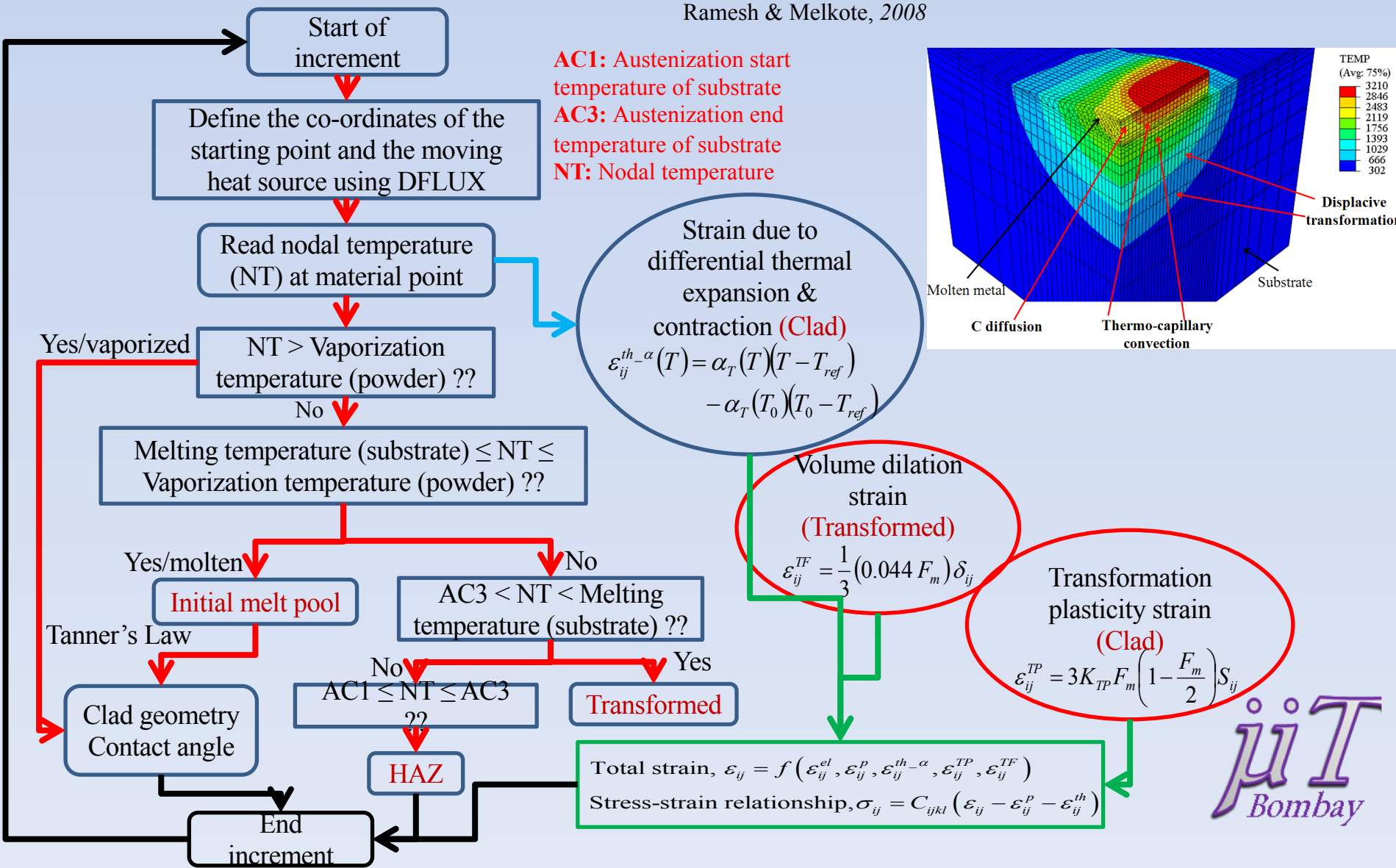
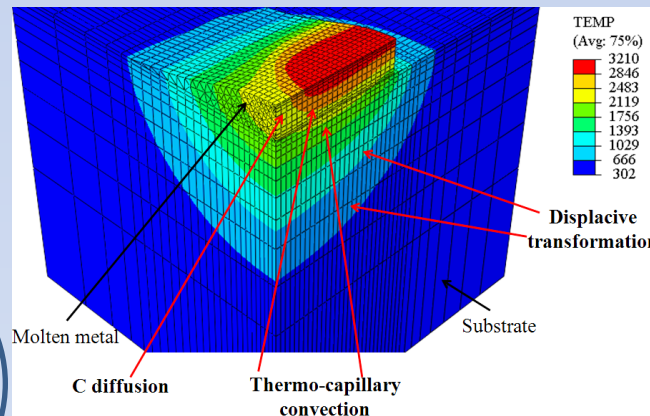



Residual Stress Evolution

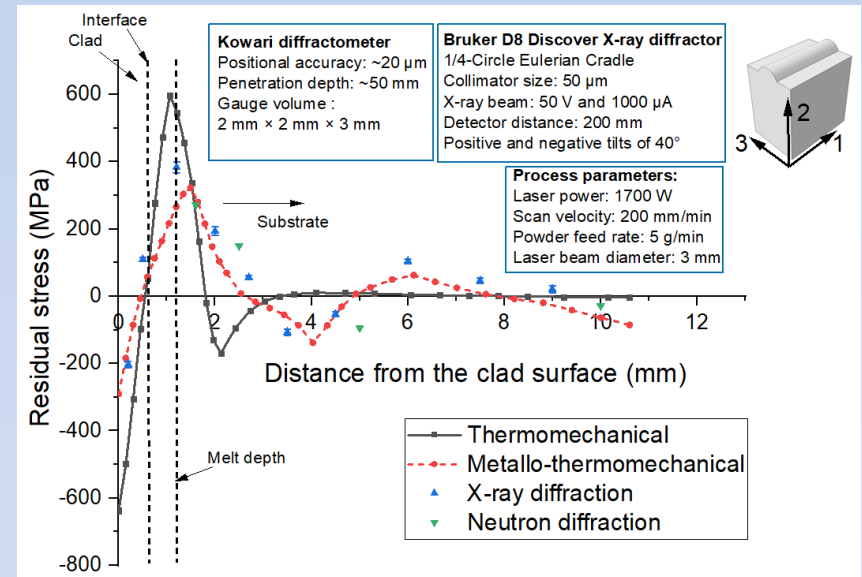
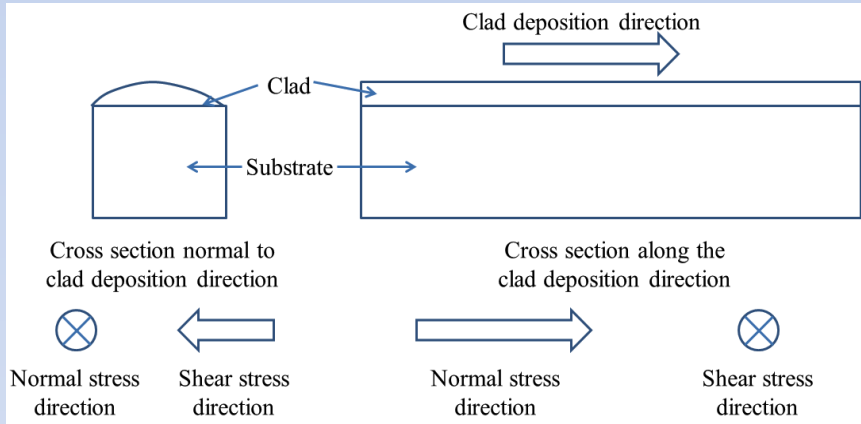

Direction of residual stress measurement

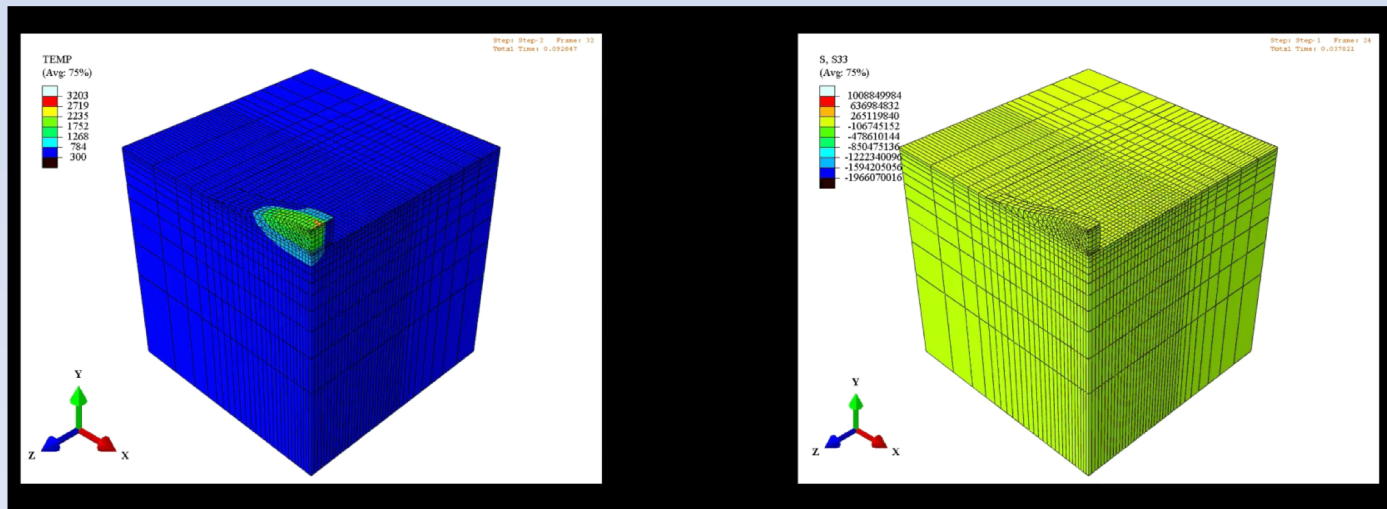

Contour of residual stress along normal direction

Other Joining Processes

- Laser Welding
- Electron Beam Welding
- Solid State Welding
 - Electrical Resistance Welding
 - Friction Welding
 - Diffusion Bonding
- Brazing
- Soldering



Laser Welding-Basics

- Laser welding is a non-contact process that requires access to the weld zone from one side of the parts being welded
- The weld is formed as the intense laser light rapidly heats the material-typically calculated in milli-seconds.
- There are typically three types of welds:
 - Conduction mode
 - Conduction/penetration mode
 - Penetration or keyhole mode.

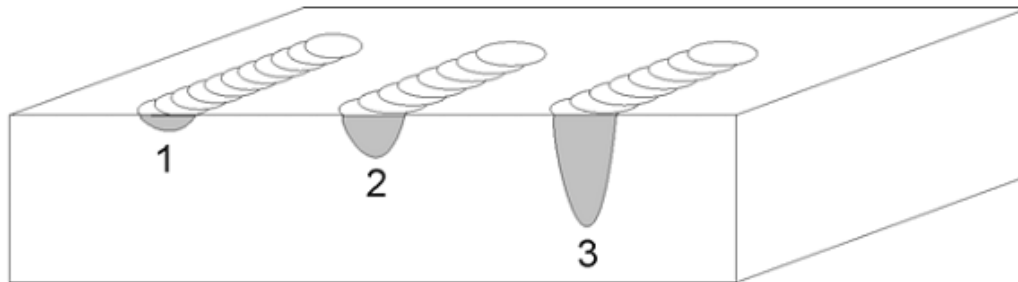

Laser Welding-Basics

- Conduction mode welding is performed at low energy density forming a weld nugget that is shallow and wide.
- Conduction/penetration mode occurs at medium energy density, and shows more penetration than conduction mode.
- The penetration or keyhole mode welding is characterized by deep narrow welds.
 - In this mode the laser light forms a filament of vaporized material known as a “keyhole” that extends into the material and provides conduit for the laser light to be efficiently delivered into the material.
 - This direct delivery of energy into the material does not rely on conduction to achieve penetration, and so minimizes the heat into the material and reduces the heat affected zone.



Process Capabilities of Laser Welding

- Sheets up to 12 mm can be joined using high power lasers (~15 kW fiber lasers)
- The speeds can be as high as 80 inches/min for high power lasers
- Very high thicknesses up to 40 mm can be joined by a 65 kW CO₂ laser
- The cost of high power lasers are very expensive and thick section welding is typically not recommended by laser welding processes
- Best suited for sheet metal welding but it is difficult for reflective materials, such as aluminum and copper
- It can be easily automated and the weld quality is exceptional



Electron Beam Welding

- The electron beam welding process is used in automotive in-line part production to single part batch processes in the high-cost aerospace components
- The electrons are generated if the current passes through a filament in vacuum
- An electrostatic field accelerates the electrons to 0.5 to 0.8x speed of light and shapes them into a beam for welding
- Electron beam welders use this characteristic to electromagnetically focus and very precisely deflect the beam at speeds up to 200 kHz via a pattern generator to reduce porosity
- The kinetic energy of each electron in the beam is converted into thermal energy. This transformation is stable in the high 90% range for all metals regardless of whether the electrons hit the surface at a perpendicular or shallow angle which makes the process robust



E-Beam Welding

- All grades of steel can be welded
- Low melting alloys such as aluminum and magnesium
- High melting materials such as Nickel- and Cobalt-based alloys.
- The pattern generator, unique to the EB welding process, has proven to be very powerful in stabilizing the key hole to improve the process' robustness and produce defect-free welds.

<https://ptreb.com/electron-beam-welding-information/technical-papers/electron-beam-welding-process-applications-and-equipment#Page6>

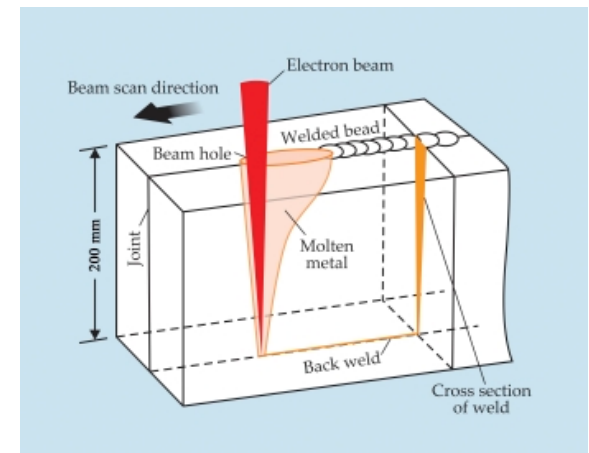

Solid State Welding

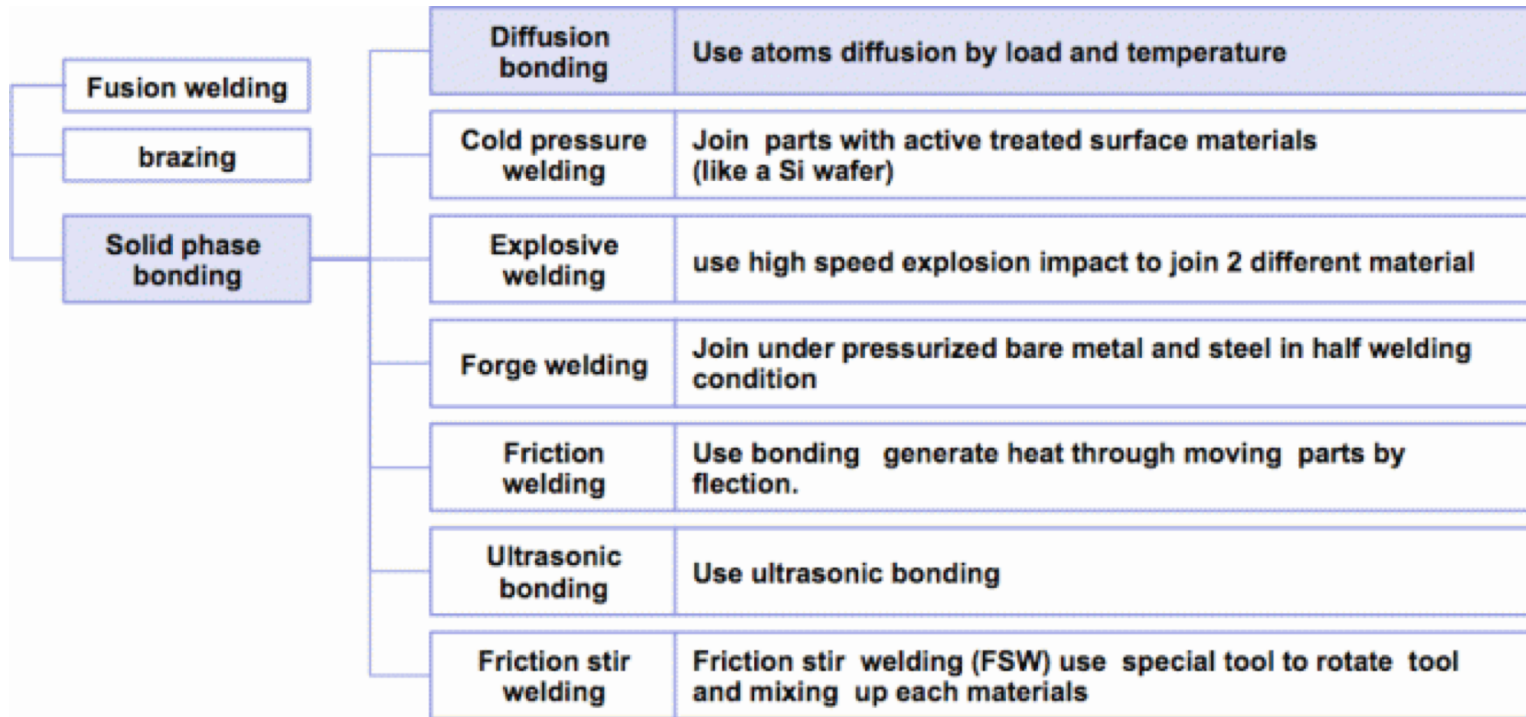

Electrical Resistance Welding

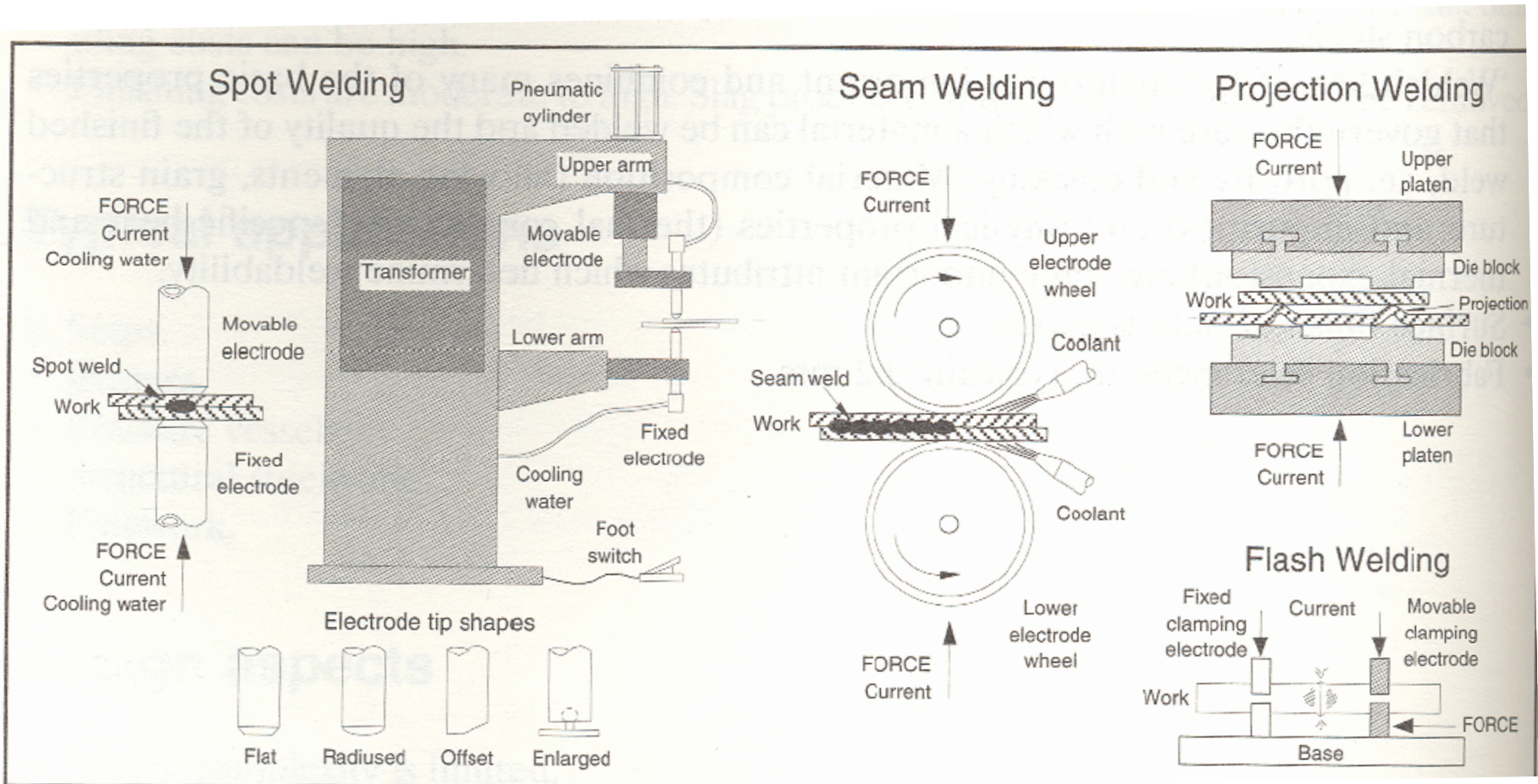

Courtesy: Process Selection, Swift & Booker



Process Variations

- Spot welding
- Seam welding
- Projection welding
- Flash welding



Process Description

- Requires no filler metal or fluxes
- Can achieve high speed production
- Is easily automated
- Does not require skilled operators
- Is used primarily on sheet metal
- Uses nonconsumable, low resistance, copper alloy electrodes



Process Capabilities

- High production rate due to short welding time
- Minimum sheet thickness = 0.3 mm
- Maximum sheet thickness = 6 mm
- Mild steel sheets up to 20 mm with expensive equipment and high current
- Materials handled are low carbon steels
- Cast iron and high carbon steel is not recommended
- Alignment tolerances for flash welding are typically 0.1-0.25 mm total
- Repeatability of ± 0.5 mm - 1mm in robot spot welding
- Surface finish is fair to good



Electrical Resistance Welding

- Advantages
 - Full automation and integration with component assembly is relatively easy
 - Little or no post-welding heat treatment is required
 - Labor and finishing costs are low
 - No filler material or fluxes required
 - Economical for low production runs
- Limitations
 - Equipment costs are high
 - Access to weld area is important
 - Spot, seam and projection could be difficult to inspect
 - Possibility of galvanic corrosion in case of dissimilar metal welding



Friction Welding



Two unique materials are rubbed together at a controlled rotational speed



Rotational rubbing motion causes materials to heat up and become plasticized



Axial force is applied for a specific amount of time and upset to create a bond



Rotators are used to control the rotational speed and force for each material

Courtesy: <http://www.teamafw.com/wjournal.htm>
American Friction Welding Inc.



Process Description

- Parts are loaded into welder, one in rotating spindle and the other in a stationary clamp
- Component in spindle is brought up to pre-determined rotational speed and then a pre-determined axial force is applied
- Rotation is stopped and increased axial force is applied until desired upset is obtained.
- Environmentally friendly process, no fumes, gases or smoke generated
- Being a solid state process the possibility of porosity and slag inclusions are eliminated



Process Variations

- Friction Welding
- Linear Friction Welding (Linear vibrations)
- Friction Stir Welding (A rotating tools stirs the material)

Refer to the process videos



Process Capabilities

- Rotation speed as high as 900m/min
- Maximum diameter of solid steel bars = 100 mm
- Maximum diameter of hollow steel pipes = 250 mm
- Materials handled are low carbon steels, stainless steels, Al alloys, Non ferrous materials, Titanium and Tungsten carbide
- Dissimilar metals can be welded
- An airtight weld is made across entire cross section, eliminating the risk of porosity, voids, leaks or cracks
- Surface finish is good



Friction Welding

- Advantages
 - Dissimilar materials normally not compatible for welding can be friction welded
 - No fluxes, filler metal or gases required
 - Joint preparation is minimal, saw cut surface most commonly used
 - Consistent and repetitive process
 - Reduces machining labor, which in turn increases capacity and reduces perishable tooling costs
 - Suitable for quantities ranging from prototype to high production
- Limitations
 - Equipment costs are high
 - One of the components should have rotational symmetry
 - Possibility of galvanic corrosion in case of dissimilar metal welding



Diffusion Bonding

- Diffusion bonding is a technology to bond materials together by applying heat and force to the materials, using diffusion of atoms.
- The materials are joined together without melting
- Diffusion bonding is technology to bond plane surface by layer by layer. Also it could bond different metal and ceramics each other with no interlayer metals. (Metal-to-metal bonding)
- Able to produce fluid device which has tiny fluid channels, or precise 3D hollow structures.

<http://www.welcon.co.jp/tech/diffusionbonding/>

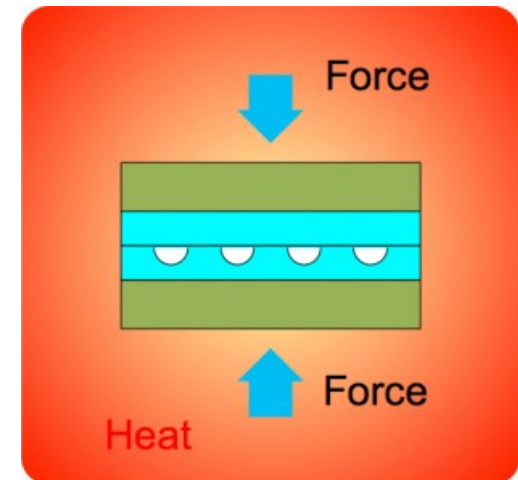

Diffusion Bonding

- It needs vacuum furnace so a bit cost intensive
- Can create complex hollow structures which is difficult by other methods



<http://www.vpei.com/diffusion-bonding/vpe35-0051-1/>



Brazing

- Brazing is a joining process traditionally applied to metals (but also to ceramics) in which molten filler metal (the braze alloy) flows into the joint.
- The melting point of the filler metal is above 450°C , but always below the melting temperature of the parts to be joined, which distinguishes the process from welding where high temperatures are used to melt the base metals together.
- The filler metal, while heated slightly above melting point, is protected by a suitable atmosphere which is often a flux. The molten filler metal cools to join the workpieces together providing a strong join between similar or dissimilar metals.



Brazing Process Contd.

- The atmospheres in which the brazing process can be undertaken include vacuum and other inert and non-inert gases using a torch, furnace, and induction coil.
- To achieve a sound brazed joint, the filler and parent materials should be metallurgically compatible, and the joint design should incorporate a gap into which the molten braze filler can be drawn or distributed by capillary action
- Ideal for joining dissimilar metals, brazing is a commercially accepted process used in a wide range of industries

Source: TWI



Soldering

- Solder is melted by using heat from an iron connected to a temperature controller. It is heated up to temperatures beyond its melting point at around 600°F which then causes it to melt, which then cools creating the soldered joint.
- As well as creating strong electrical joints solder can also be removed using a desoldering tool
- Solder is a metal alloy used to create strong permanent bonds; such as copper joining in circuit boards and copper pipe joints. It can also be supplied in two different types and diameters, lead and lead free and also can be between .032” and .062”. Inside the solder core is the flux, a material used to strengthen and improve its mechanical properties
- Tin, lead, brass or silver are the metals used in solder for soldering joints



Soldering Contd.

- Occasionally at the site of the joint, there are impurities such as oil, dirt or oxidation, the flux helps prevent oxidation and can sometimes chemically clean the metal.
- The flux used is **rosin flux** which helps the mechanical strength and electrical contact of electrical joints.
- Sometimes it is also possible to apply a 'wetting agent' to reduce the surface tension.

Source: TWI



Summary

- Welding basics
- Arc welding processes
 - SMAW
 - SAW
 - GMAW
 - GTAW
 - PAW
 - Analysis

• Other joining processes

