



Biomass Power

Rangan Banerjee
Department of Energy Science and Engineering
IIT Bombay

Invited talk at National Symposium on Power for Sustainable Development 2008 at COEP, Pune, Sept. 26, 2008





Sustainable Energy Systems?

- Present consumption pattern predominantly -fossil fuel
- Limited fossil reserves
- Adverse environmental impacts
- Unsustainable
- Need for transition to clean technology renewable energy systems, efficiency , nuclear,

India- Primary Energy Balance

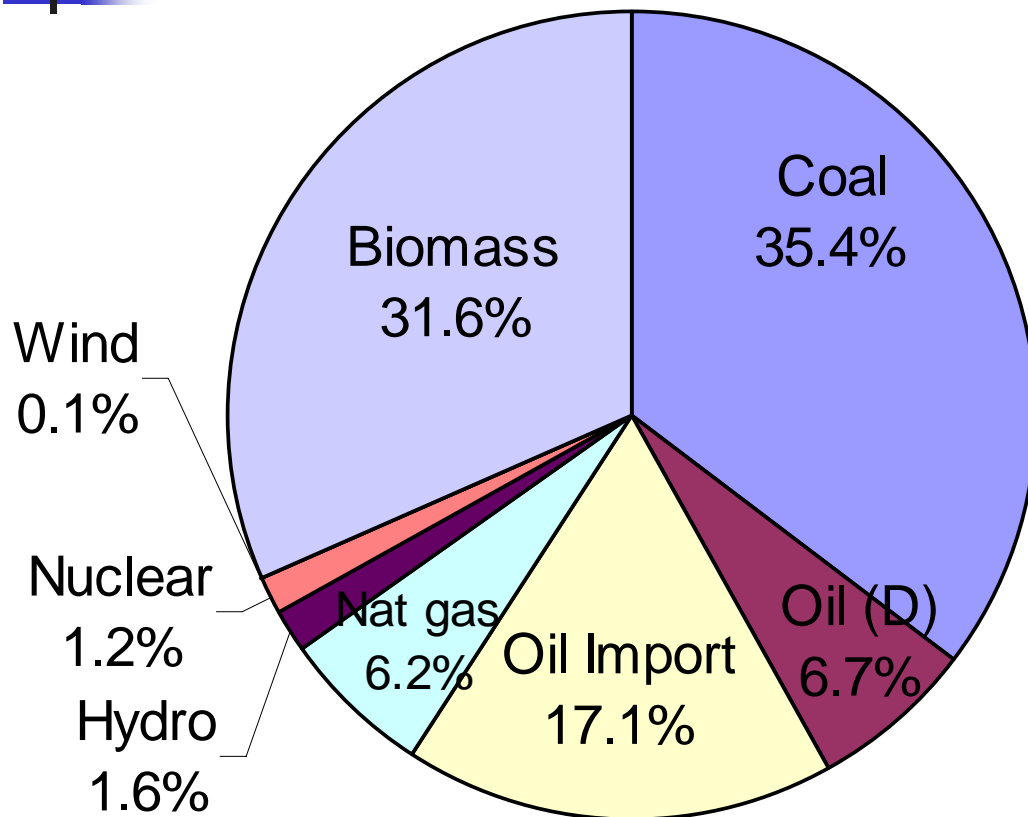

2003-4

Total comm

14000 PJ

Biomass 6500
PJ (33%)

Total

20500 PJ

19700 PJ (-non
energy)



India - Fossil Fuel reserves

Fuel	Reserves	Prod'n 2003-4	R/P ratio
Coal ^{+Lignite} (Million Tonnes)	34000	414	~83 (P) 140 P+I
Oil (Million Tonnes)	760	33 (117)	23 (7)
N.Gas Billion m ³	920	32	29
Uranium Tonnes	61000	PHWR	~50 10GW

Data Source Plg Comm IEPC, 2006



Renewable Energy Options

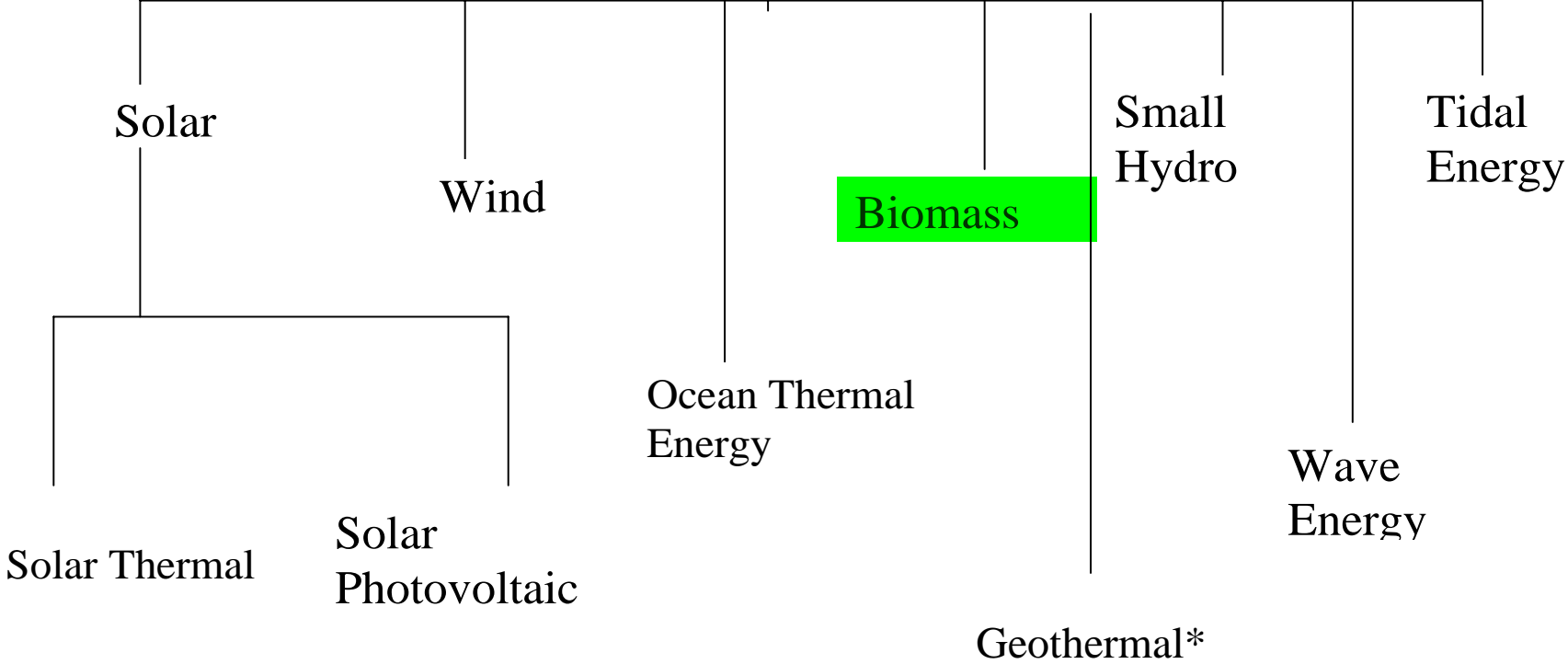



Applications

- Power Generation
- Cooking
- Water Heating
- Refrigeration and Air Conditioning
- Distillation
- Drying
- Space Heating



Power Generation Options

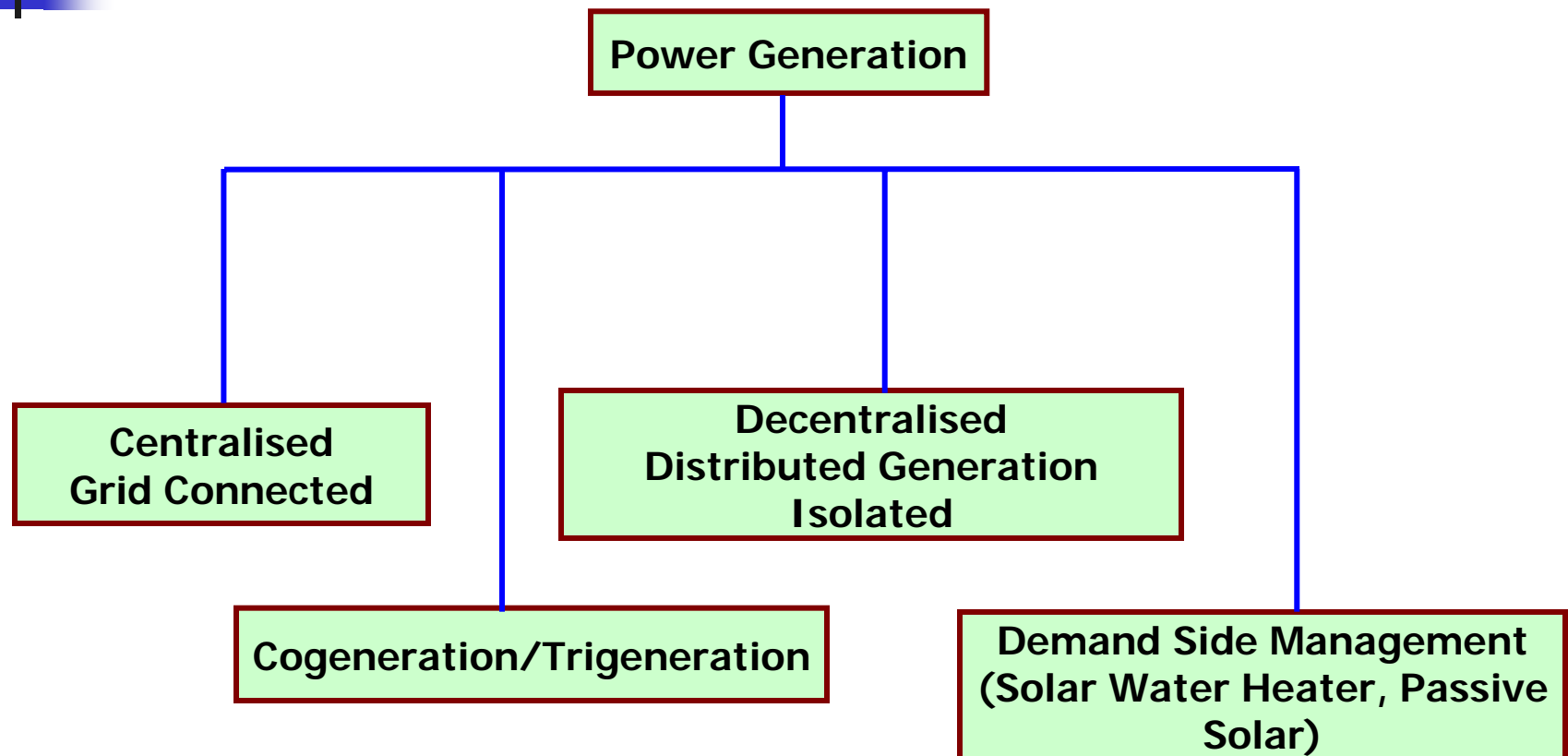

World Renewable Electricity Capacity (1998)

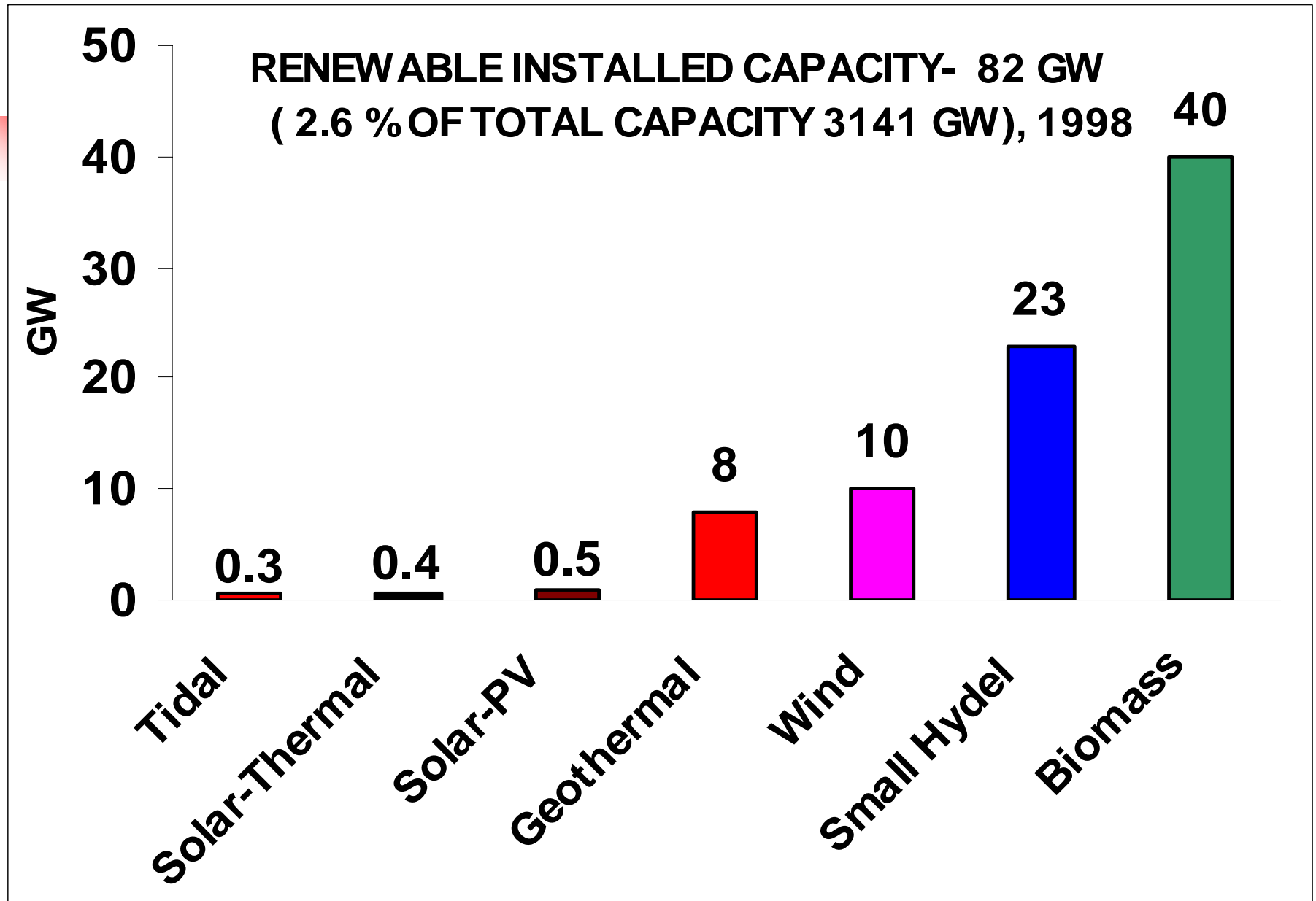

World Renewable Electricity Capacity (2005)

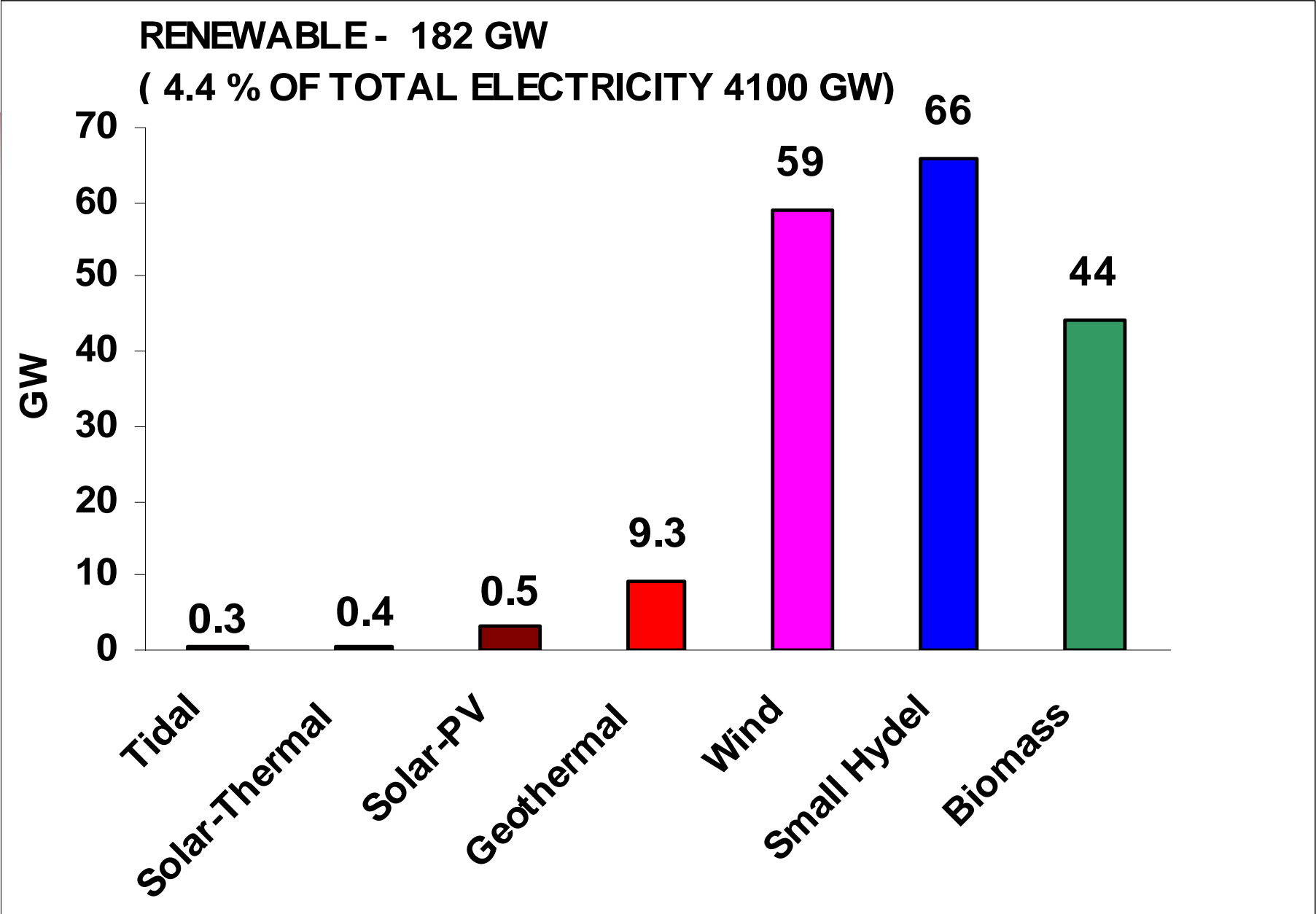

Renewable installed capacity and generation

	Installed Capacity* (MW)	Estimated Capacity factor	Estimated Generation (GWh)
Wind	7845	14%	9621
Biomass Power	606	70%	3185
Biomass Gasifier	86	60%	527
Bagasse Cogeneration	720	60%	3784
Small Hydro	2046	40%	7169
Waste to Energy	55	50%	241
Solar PV	2.74	20%	5
Total	11360	25%	24380

*as on Jan 1, 2008



Biomass Power Generation

- Biopower 1467 MW of installed capacity
7737 GWh annual generation
- Biomass – fuelwood, agricultural residues-
rice husk, bagasse, sugarcane trash, coconut
shells, animal wastes
- Reduced GHG emissions
- Energy Security



Renewable Installed Capacity trend

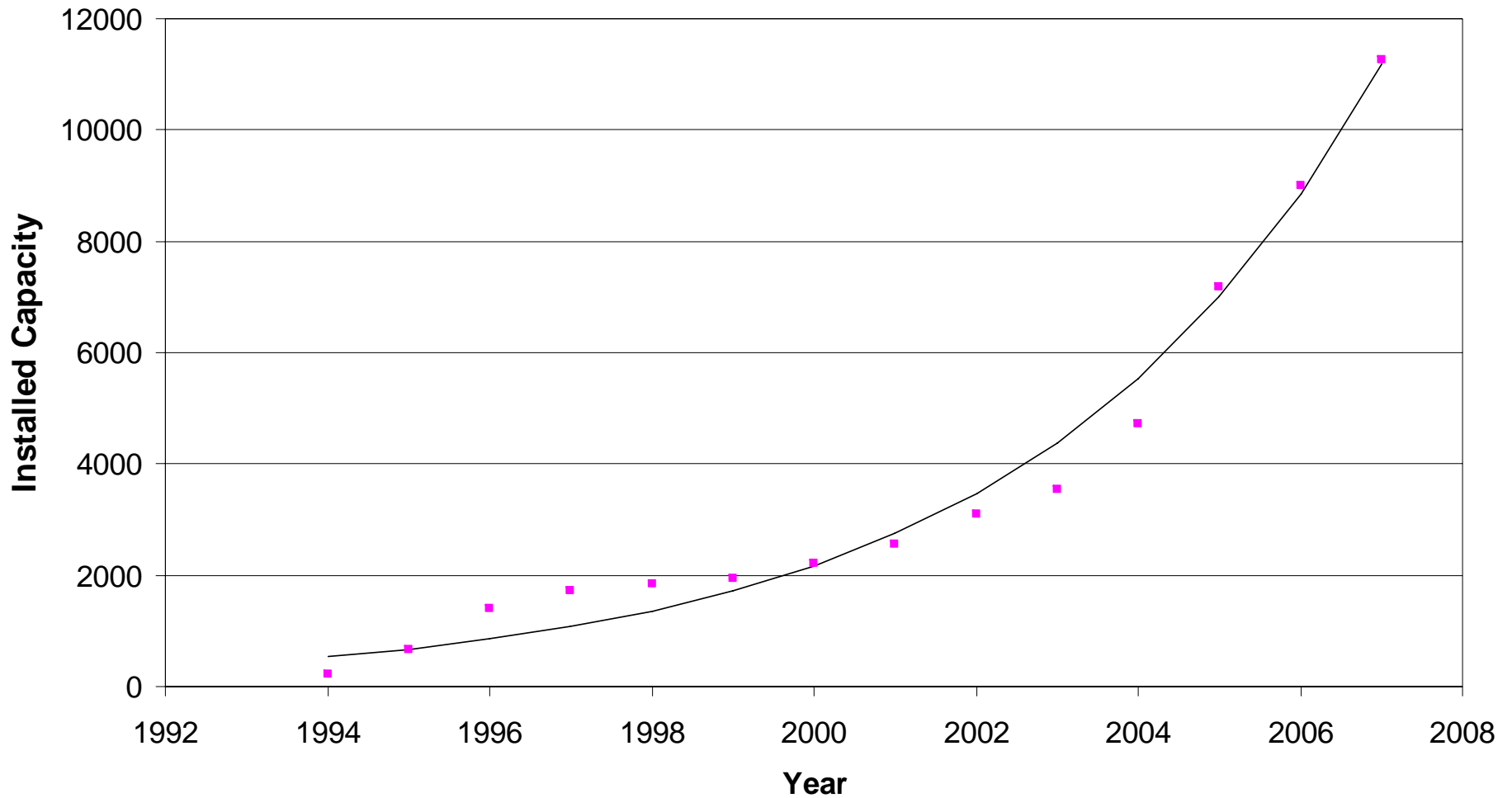

Renewable Share in Power

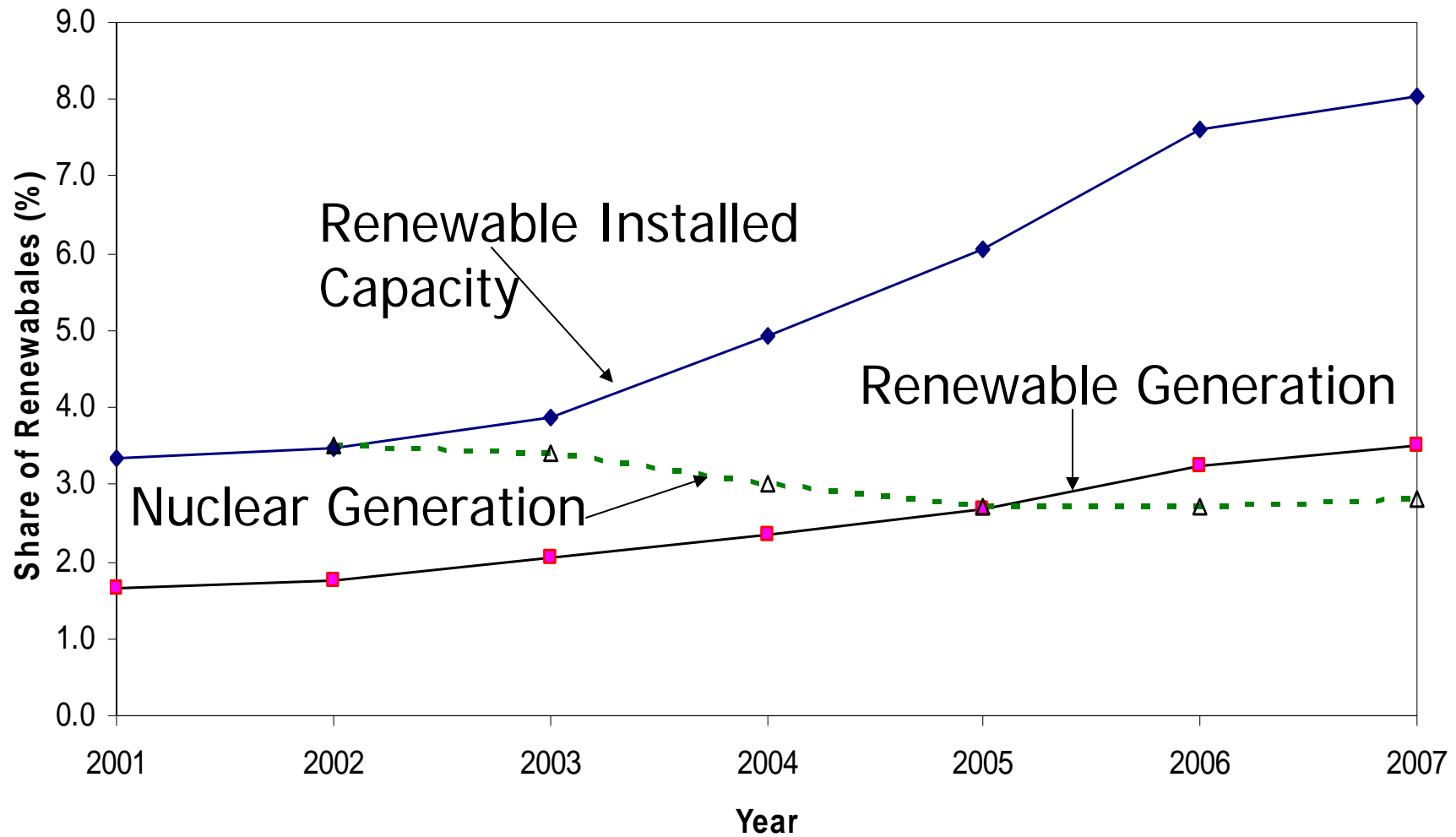

Growth of Biomass based power in Tamil Nadu

Installed capacity

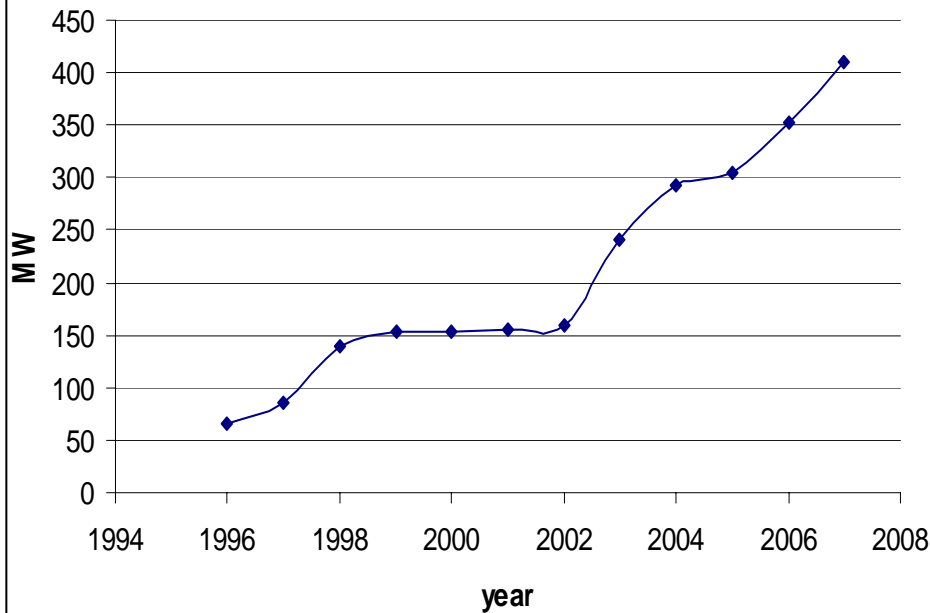

Generation

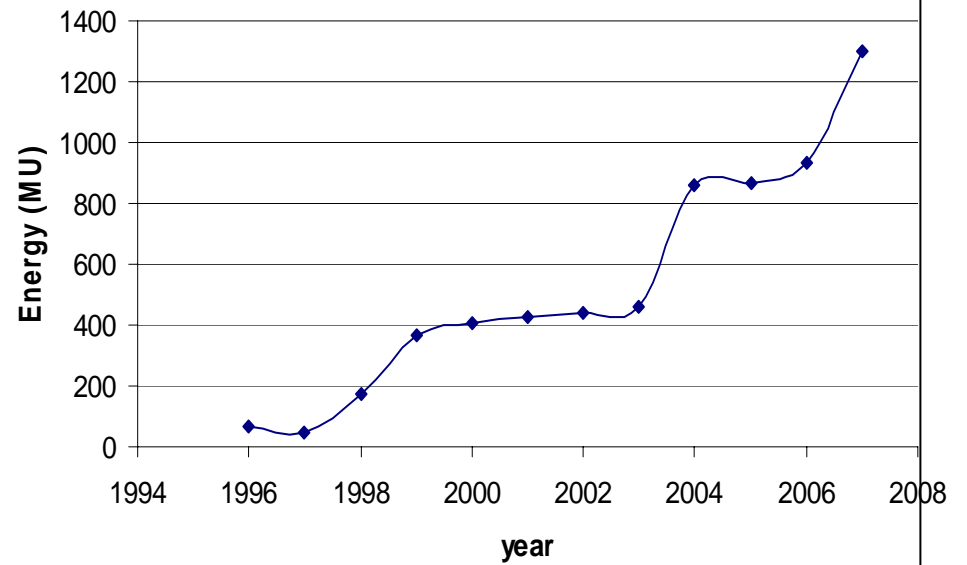

Growth rate in installed capacity 17.9%/year from 1996-2007

Average PLF 36.2%



Perspective Plan (MNRE)

Table 9.1: Perspective plan for grid-interactive renewable power for 2022, i.e. end of 13th Plan period:

(capacity in MW)

Resource	Upto 9 th Plan	10 th Plan	11 th Plan	12 th and 13 th Plans	Total
Wind power	1667	5333	10500	22,500	40000
Small hydro power	1438	522	1400	3140	6500
Bio power	368	669	2100	4363	7500
Solar Power	2	1	-	-	3
Total	3475	6525	14000	30003	54003

Source: 11th Plan proposal MNRE Govt. of India



Biomass Conversion Routes

BIOMASS

THERMOCHEMICAL

BIOCHEMICAL

COMBUSTION

GASIFICATION

PYROLYSIS

DIGESTION

FERMENTATION

**RANKINE
CYCLE**

PRODUCER GAS

BIOGAS

ETHANOL

ATMOSPHERIC

PRESSURISED

Duel Fuel

SIPGE

Gas Turbines

Biomass Power

- Higher Capacity factors than other renewables
- Fuelwood, agricultural residues, animal waste
- Atmospheric gasification with dual fuel engine -
- 500 kW gasifier - largest installation
- Combustion – 5-18 MW
- Rs 2.50-4/kWh



100 kWe Pfutseromi village, Nagaland



Kaganti Power Ltd. Raichur Distt. A.P. 7.5 MW



Biomass Combustion Example

- Raghu Rama Renewable Energy, Tamil Nadu 18 MW, steam 67 bar, 500 °C
 - Fuel: prosopis juiflora, rice husk, coal (supplementary)
 - 65 crore investment 2004
 - PLF : 84% 2005, 81% 2006 , Availability 91%, Efficiency 17%
 - Coal – 7% of input 2005, 5% 2006
 - Annual CO2 savings 91000 tonnes
- (source:Monitoring report UNFCCC no 0111)



Biomass Gasifier Examples

Description	Hosahalli	Hanumanthanagara
Year of establishment	1988*	1996
Size of village (number of households)	35	58
Population	218	319
Energy plantation (ha) raised	4	8
Installed capacity (kWe)	20	20
Installed end-use capacity (load)		
Lighting	4.0	4.0
Drinking water	2.6	2.6
Flour mill	5.6	5.6
Irrigation pump	18.5	25.5
Total installed end-use capacity	30.7	37.7

Source: Ravindranath et al (2004)

Biomass Gasifier Example

Arashi HiTech Biopower,
Coimbatore

- 1 MW grid connected
- 100% producer gas engines
- Two gasifiers – coconut shells, modified to include other biomass
- Chilling producer gas with VARS operated on waste heat





**Bio-diesel based power
plant of 10 kW rating
(Raipur, Chattisgarh)**

Isolated power Load profile

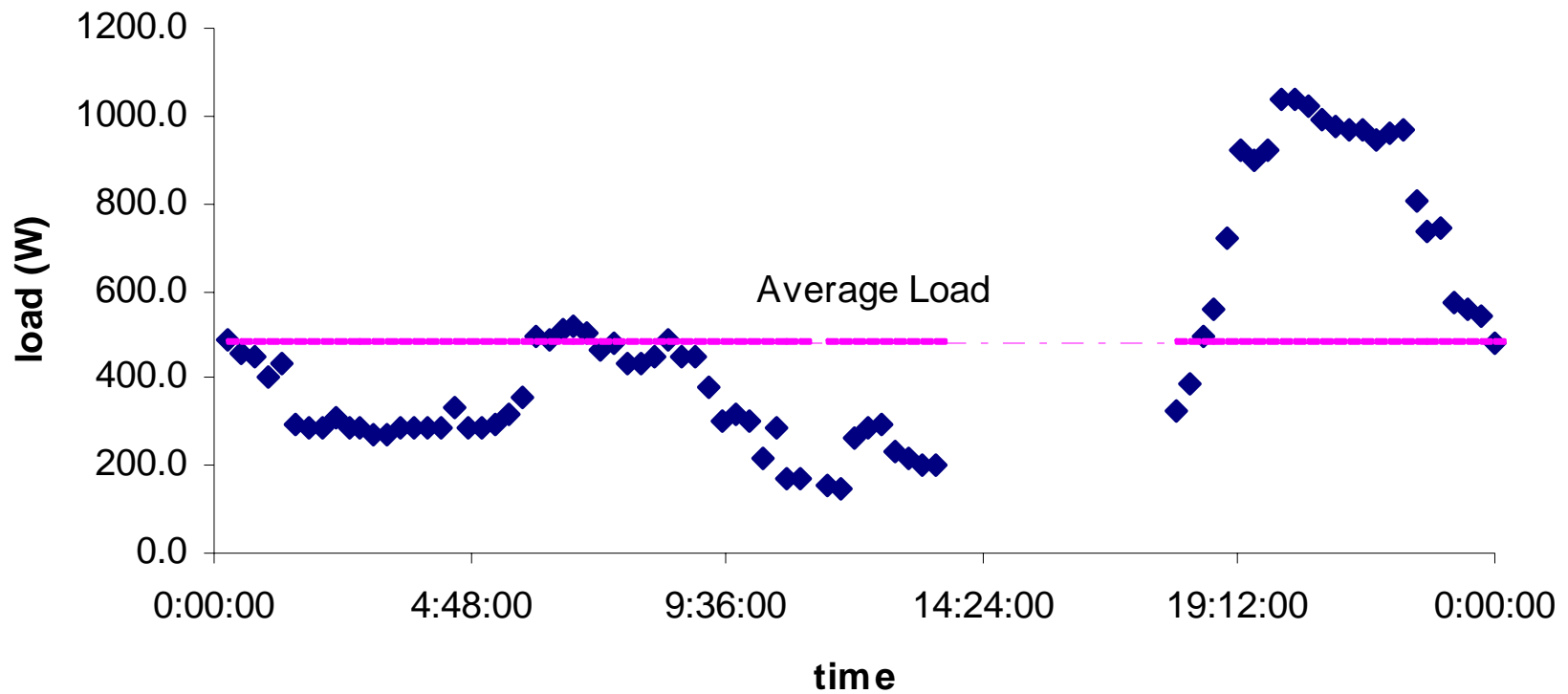

Data from 5 kW PV system near Lonavla

Biogas

- 45-70% CH₄ rest CO₂
- Calorific value 16-25MJ/m³
- Digester- well containing animal waste slurry
- Dome - floats on slurry- acts as gas holder
- Spent Slurry -sludge- fertiliser
- Anaerobic Digestion- bacterial action
- Family size plants 2m³/day
- Community Size plants 12- 150 m³/day
- Rs 14- 19000 for a 2m³ unit
- Cooking, Electricity, running engine

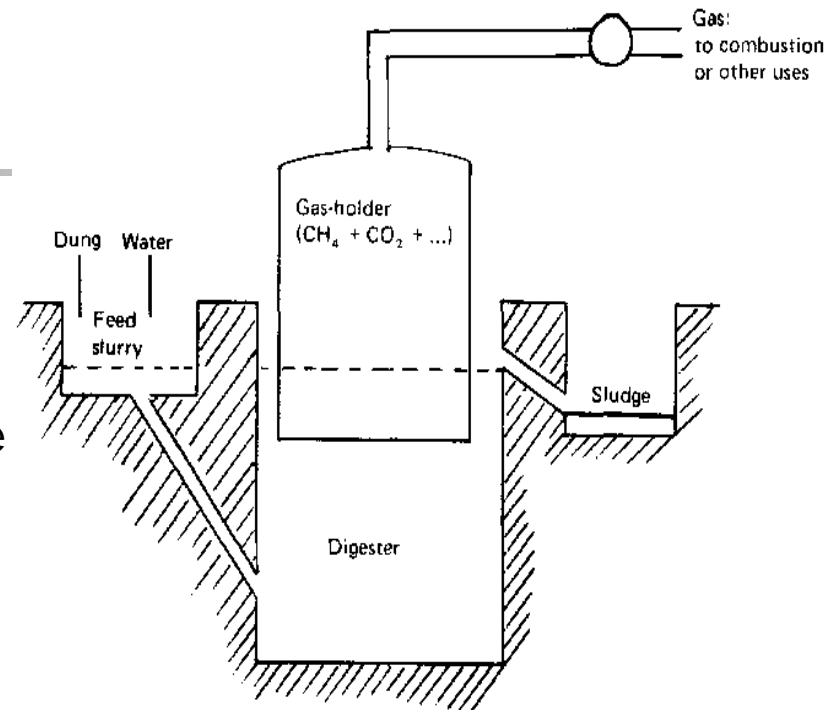

Pura, Karnataka

Urban wastes-Projects

- 6.0 MW Project at Hyderabad.
- 6 MW Project at Vijayawada
- 5 MW project at Lucknow
- Biomethanation for Treatment of Slaughterhouse Waste at Medak, Andhra Pradesh
- Power Generation from Biogas Generated at Sewage Treatment Plant, Surat:
- Biomethanation Plant for Mixed Wastes at Vijayawada
- Power generation through Biomethanation of Animal Waste at Ludhiana
- Biomethanation Plant for Vegetable Market Wastes at Chennai

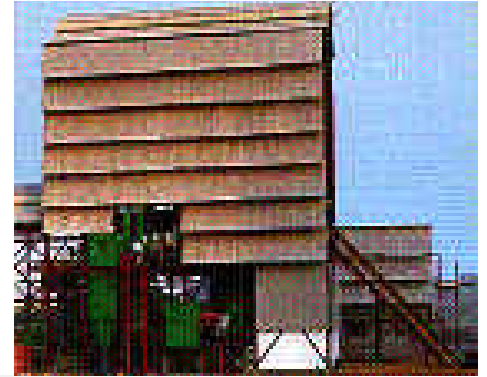

Biomethanation Plant example

Cattle dung, urban waste

High rate

Biomethanation

2.4 acres land

1 MW grid connected
+ cogeneration

13.4 crores

UNDP-GEF



1-MW power project based on cattle dung at Haebowal Dairy Complex, Ludhiana, Punjab



Bagasse Cogeneration

Incremental Capital Cost (Rs/kW)	30000		
Life	20 years		
Boiler Efficiency	70%		
Bagasse NCV = 3400 kcal/kg (dry basis), Price Rs 1.50/kg Discount rate = 10%, O&M cost = Rs 0.5/kWh 2500 tcd plant 9.5 MW export, 0.93 kg extra/ kWh			
Load factor	0.4	0.5	0.6
Rs/kWh	2.60	2.40	2.27

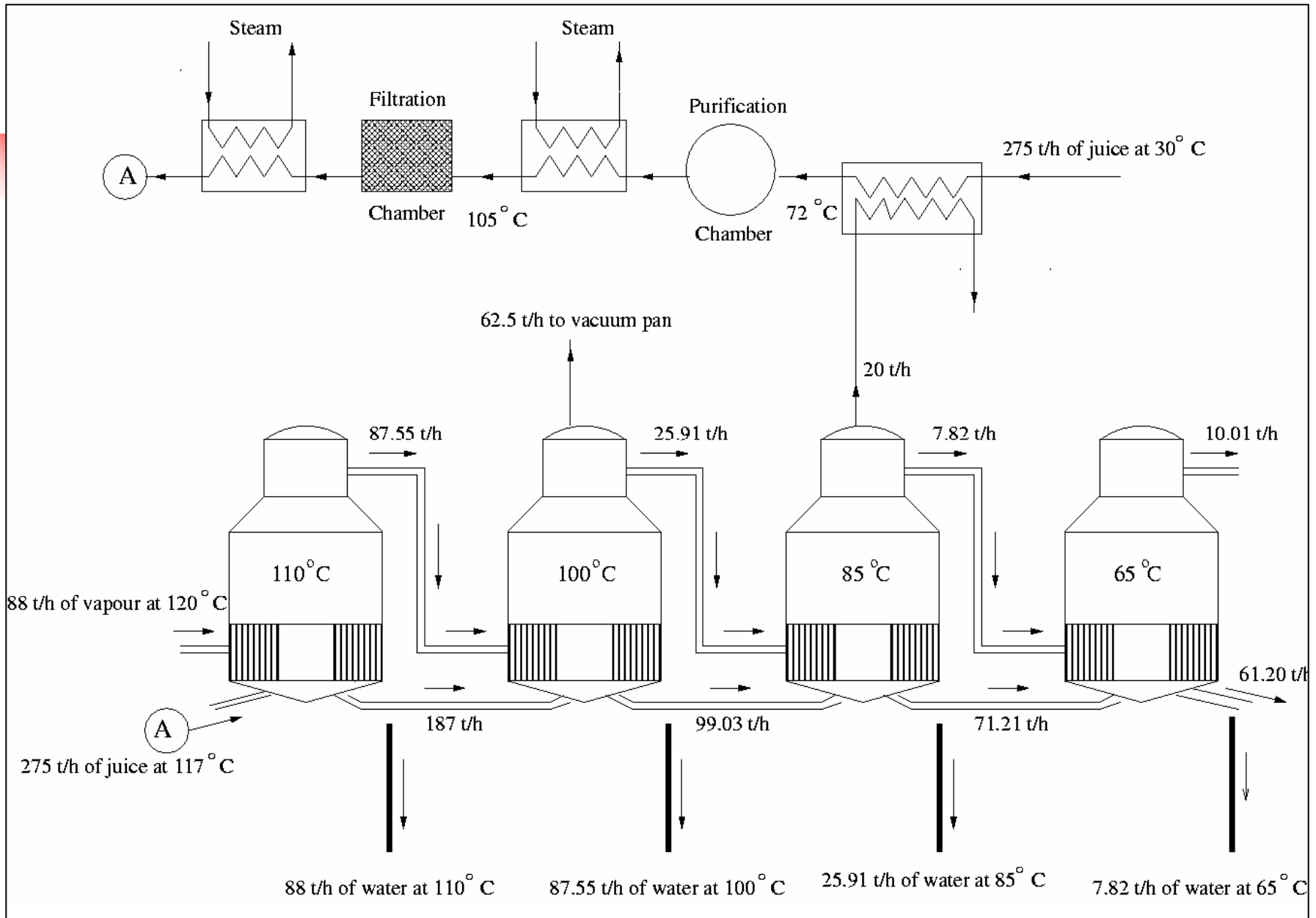

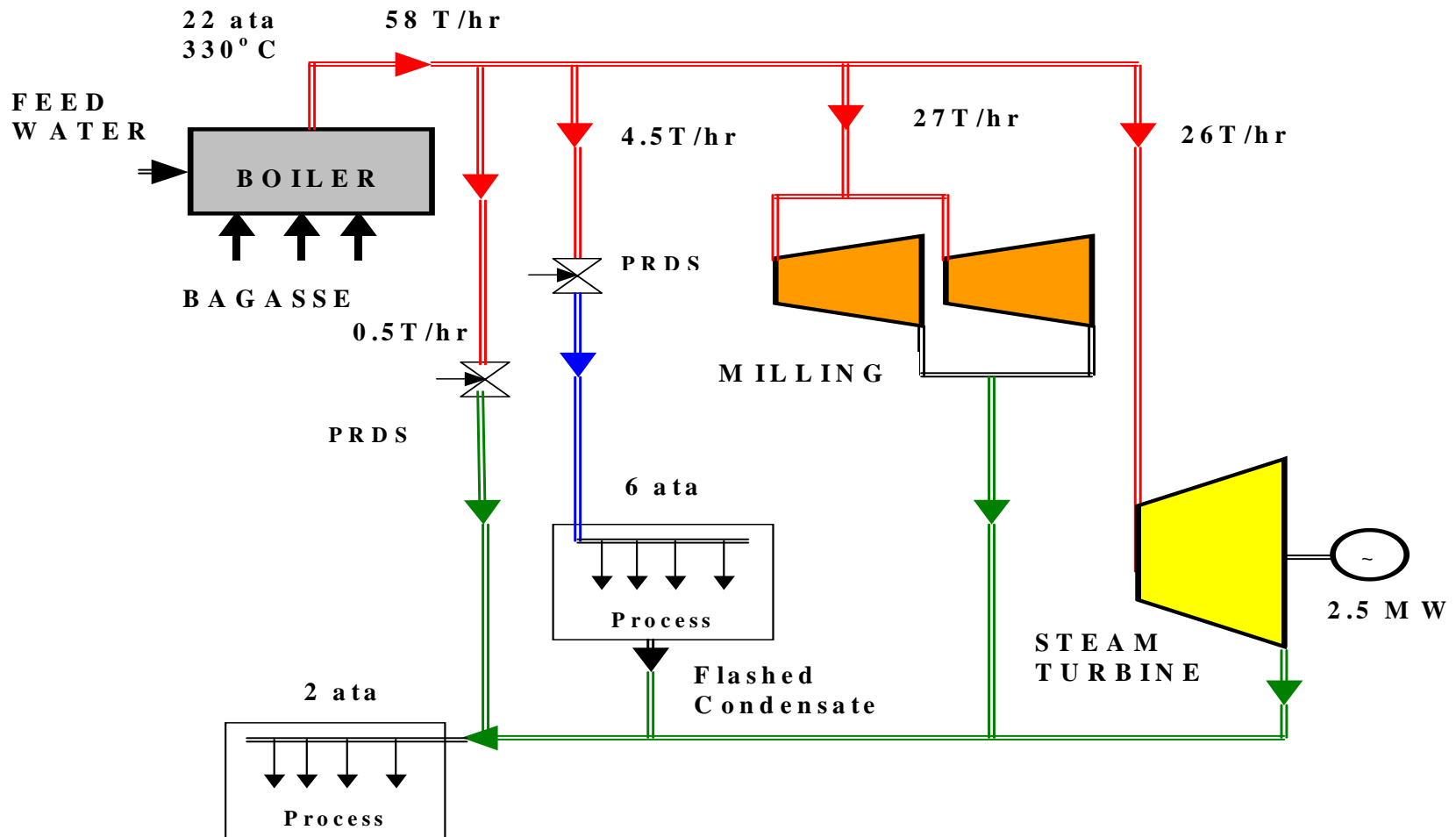

Schematic of typical 2500 tcd Sugar factory

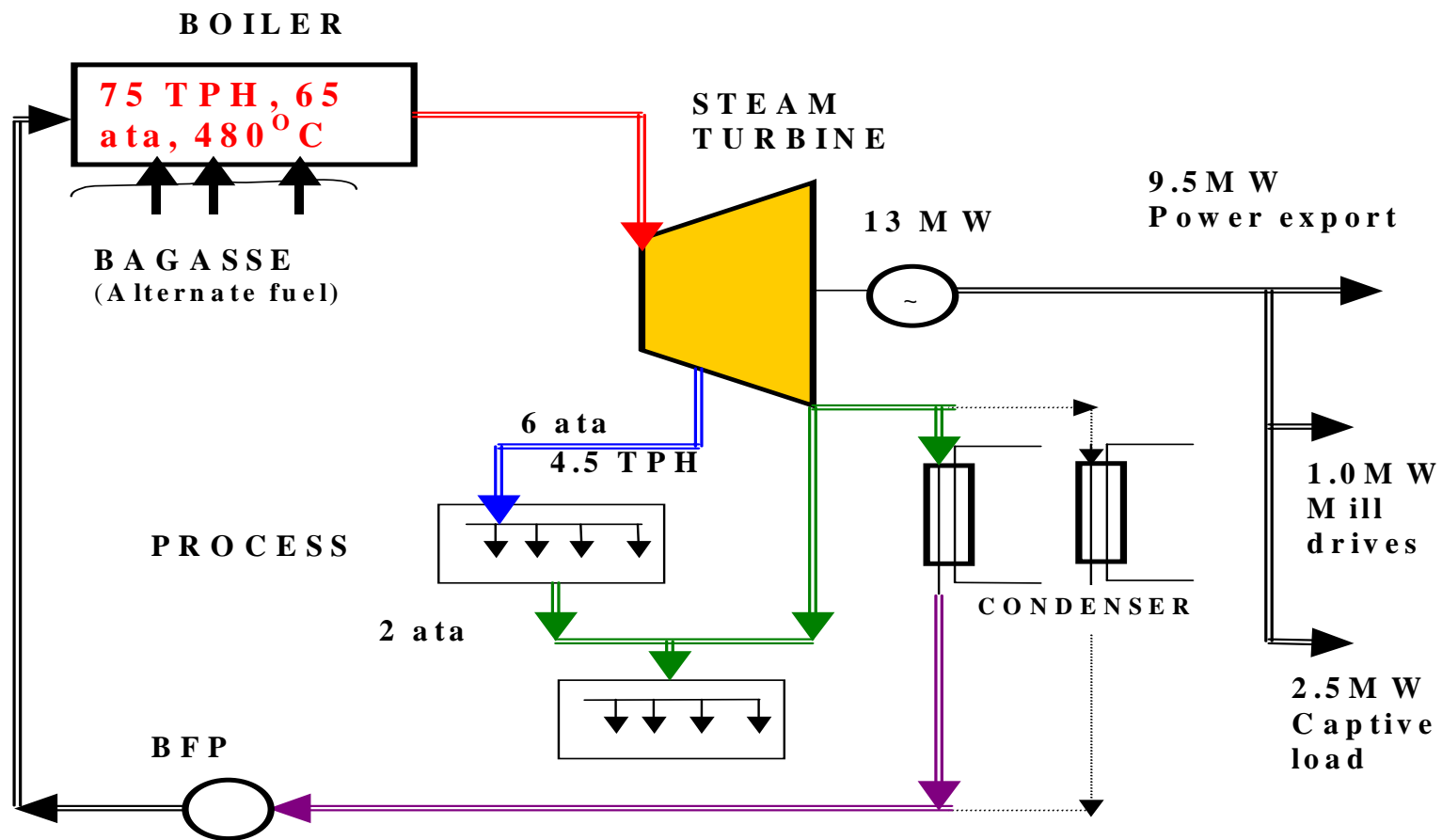

PROPOSED PLANT CONFIGURATION: OPTION 2

Comparison of Power Generation Methods

	Coal	PV	Wind	Biomass Gasifier
Efficiency (%)	35-40	8-14	30-40	20-30
Emissions (kg CO ₂ /kWh)	0.85-0.9	0.05-0.13	0.012-0.04	0.06-0.08
Net Energy Ratio	0.35-0.4	1.6-4.2	8-26	8.5-12.5

Source: Manish et al



Incentives for Biomass Power

- Preferential feed in tariffs - Maharashtra Rs. 3.05/kWh (cogen), Rs. 3.04-3.43 (biomass), A.P., Chattisgarh, Gujarat, Harayana, Karnataka, Kerala, M.P., Punjab, Rajasthan, T.N., U.P. Rs.2.63-4.0/kWh
- Renewable purchase obligation - 2-10% for different states
- MNRE incentives – Capital subsidies
- Fiscal incentives, financial through IREDA....



Summing Up

- Biomass Power – 1500 MW – Grid connected – Issues of supply- land (food vs fuel), Cogeneration cost-effective, combustion-almost
- Isolated power- load factor – link with local industry
- Employment generation
- Climate Change as a driver- National bio mission?
- Innovative financing
- Technology development , R &D – joint sector 'National Bio-Power corporation'
- Biotechnology – Microbial fuel cells, Bio-hydrogen
- Independent assessment, reporting
- India as a global leader?

End-Note

© Original Artist
Reproduction rights obtainable from
www.CartoonStock.com

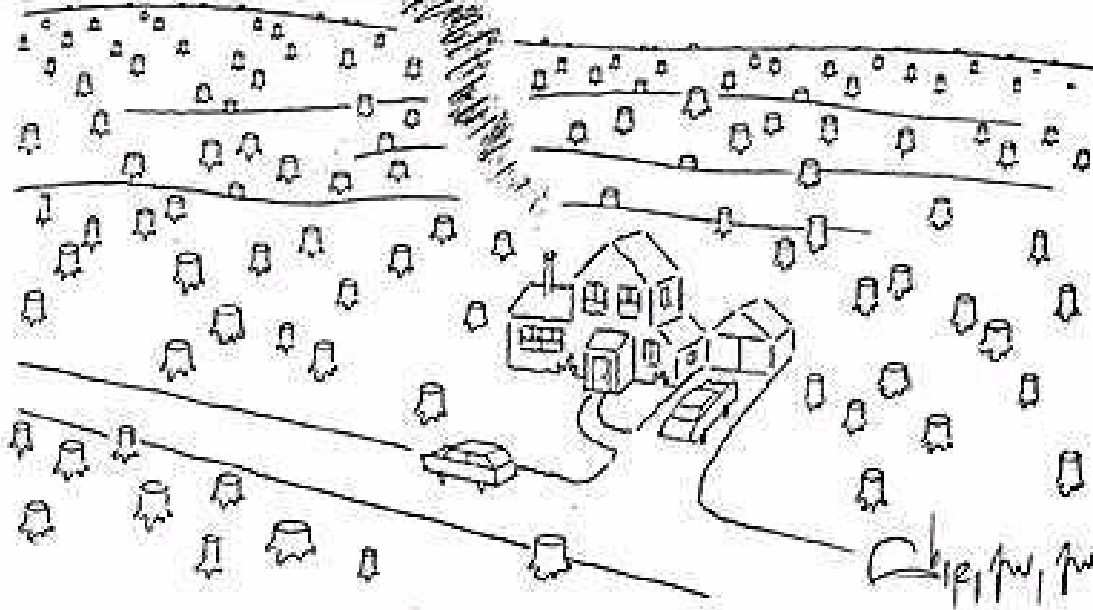

"Can you believe it? Since we installed our wood-burning stove,
we've spent next to nothing on heating oil."

vsh0196l.jpg

Source:
www.cartoonstock.com

Thank you



References

- AKNReddy, R H Williams, T. Johannson, Energy After Rio- Prospects and Challenges-, UNDP, 1997, New York.
- MNES Annual Reports, 2001-2008
- Integrated Energy Policy Report, Planning Commission, 2006
- 11th Five year plan proposal, MNRE, Govt of India
- www.mnes.nic.in
- Ravindranath et al, Current Science, 2004
- Banerjee, Comparison of DG options, Energy Policy, 2006
- Martinot, World Renewables Assessment, 2007
- Monitoring report UNFCCC no 0111
- Manish, Pillai, Banerjee, 'Sustainability analysis of renewables', Energy for Sustainable Development , December 2006