



Modelling of Energy Systems

Rangan Banerjee
Department of Energy Science and Engineering
IIT Bombay

Seminar at EPFL Lausanne on June 9, 2008





Indian Examples

- Optimal response to time of use tariff
 - process scheduling
 - cool storage
 - cogeneration
- Benchmarking of glass furnace
- PV- Battery storage – Design space
- Decision Support System for energy planning
- Solar Water Heater Diffusion

Load curve of a typical day –MSEB

(8/11/2000 source: WREB annual report-2001)

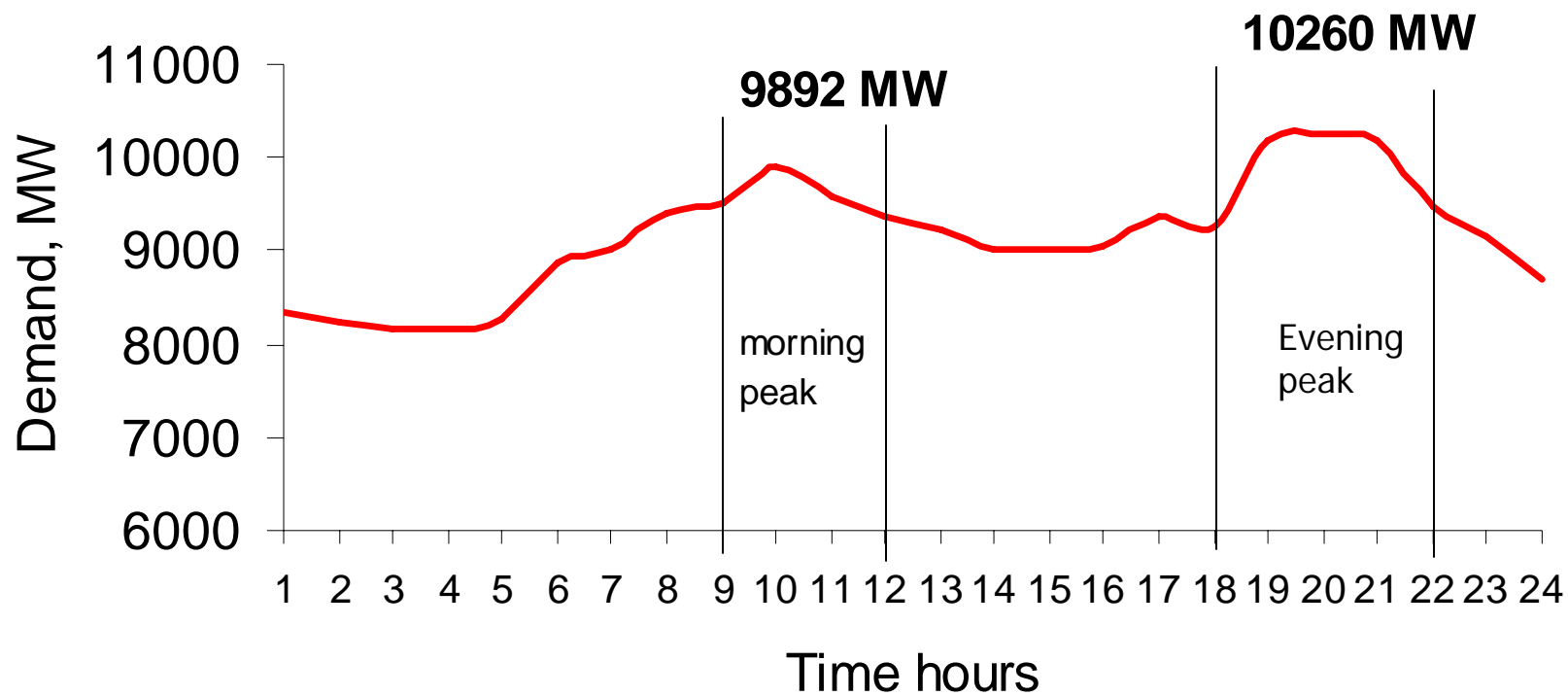

Sample Industrial Load Profile (Mumbai)



WEEKLY LOAD CURVE

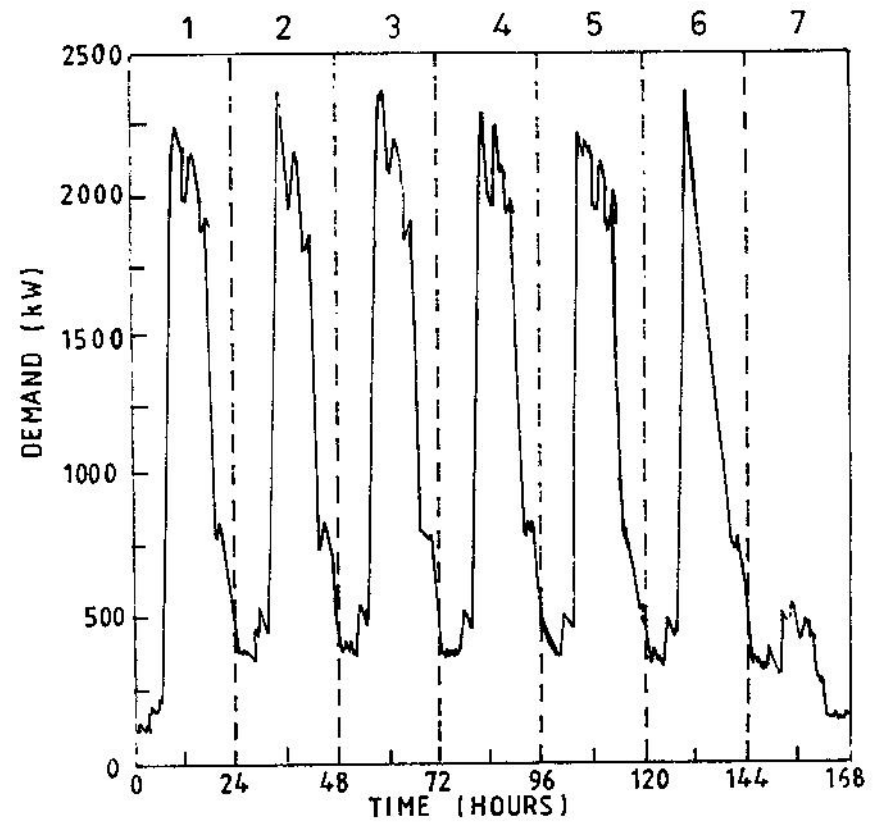

Time of Use Tariff (MSEB-HT Ind., Jan 2002)

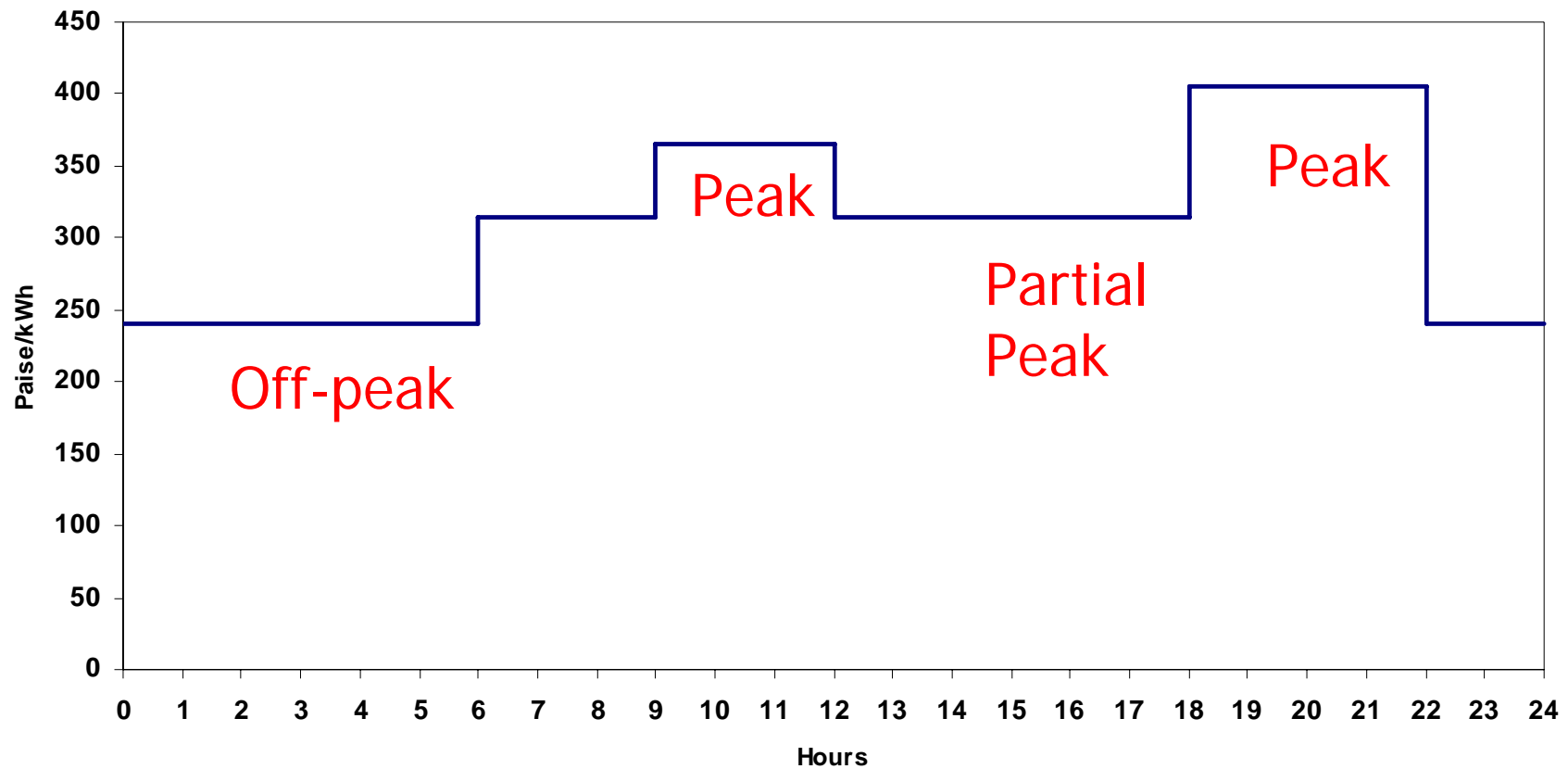



ILM Research Objective

- Determine optimal response of industry for a specified time varying tariff –
develop a general model applicable for different industries
 - Process Scheduling- Continuous/ Batch
 - Cool Storage
 - Cogeneration



Process Scheduling

- Variable electricity cost normally not included
- Flexibility in scheduling
- Optimisation problem – Min Annual operating costs
- Constraints – Demand, Storage and equipment
- Models developed for continuous and batch processes (Illustrated for flour mill and mini steel plant)
- Viable for Industry



Process Scheduling

- Batch processes- batch time, quantity, charging, discharging, power demand variation (load cycles)
- Raw material constraints, Allocation constraints, Storage constraints, Sequential Constraints, maintenance downtime

Steel Plant Flow Diagram

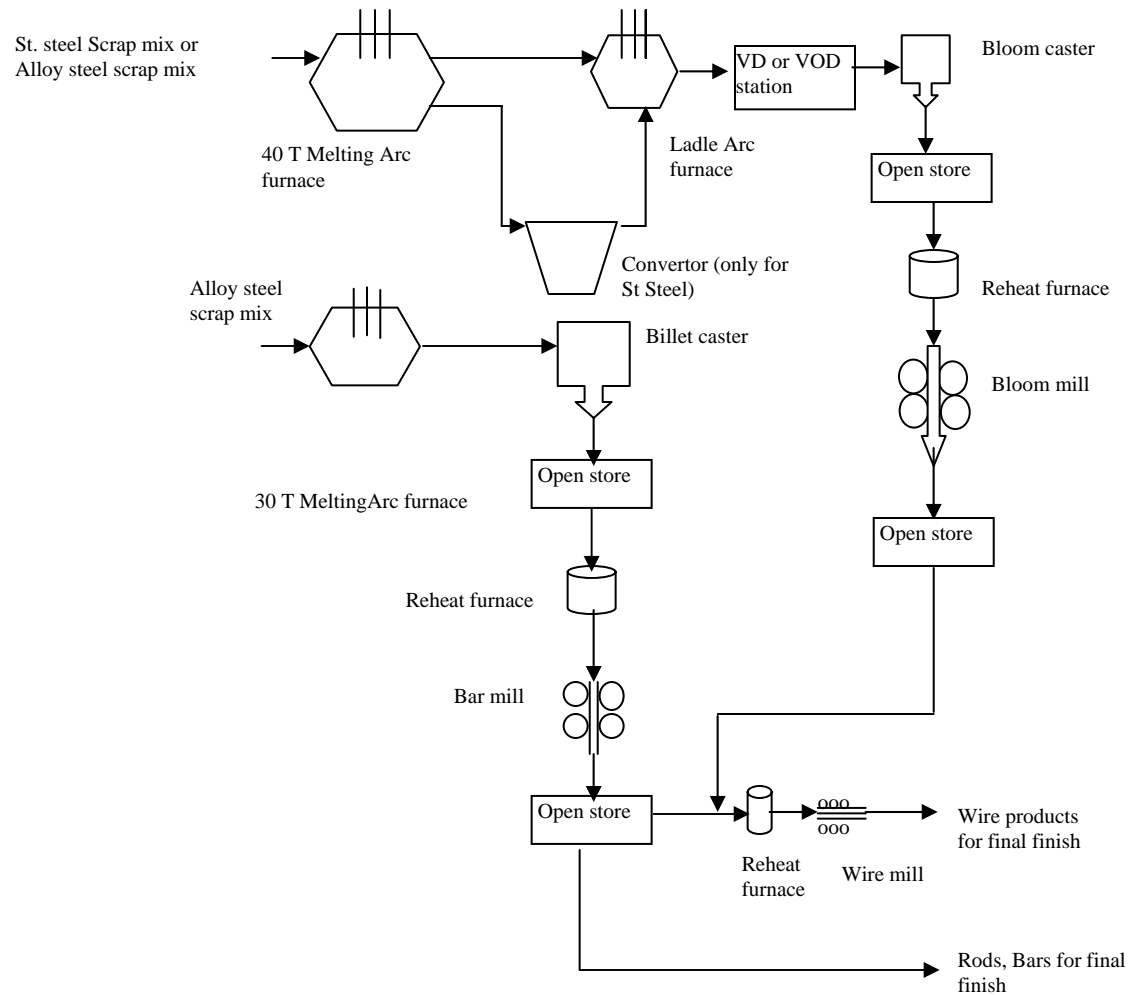

Flour Mill

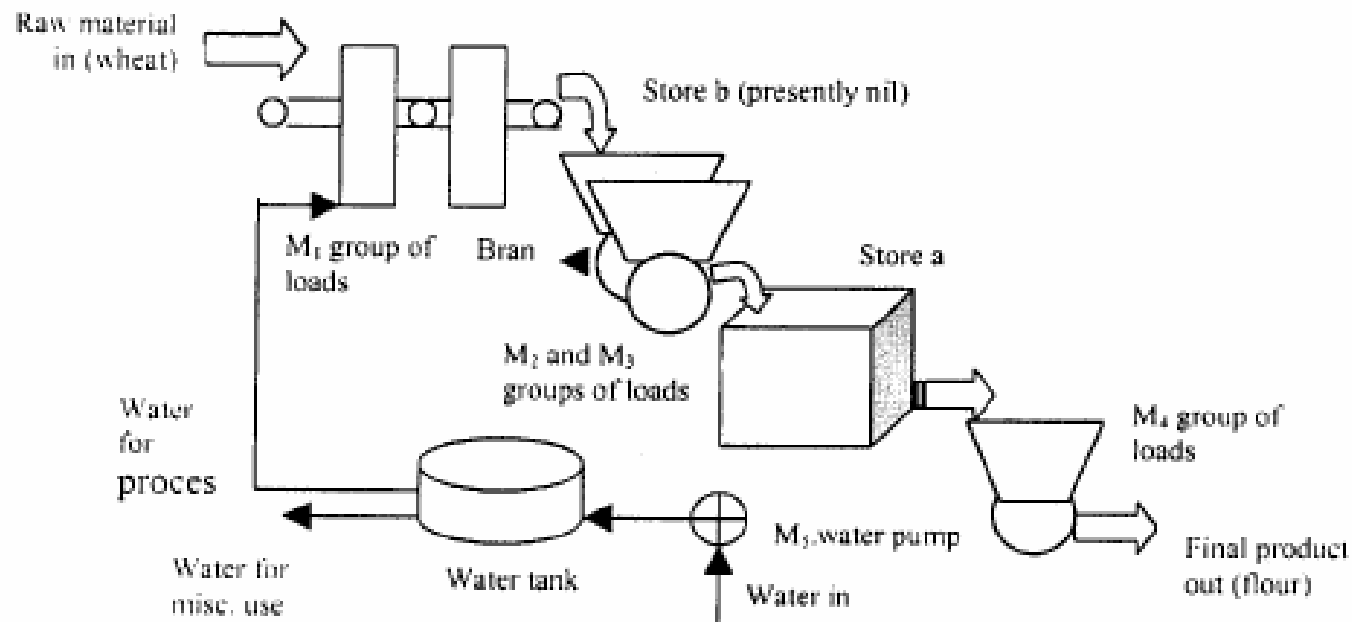

Group of process interlocked loads

M₁ - conveyor belts, dry stirrer, separators, washers and conditioners

M₂ - grinder mills, conveyors set 1

M₃ - grinder mills, conveyors set 2

M₄ - roller mills, plansifiers, pneumatic lifters

M₅ - water pump

Steel Plant Optimal Response to TOU tariff

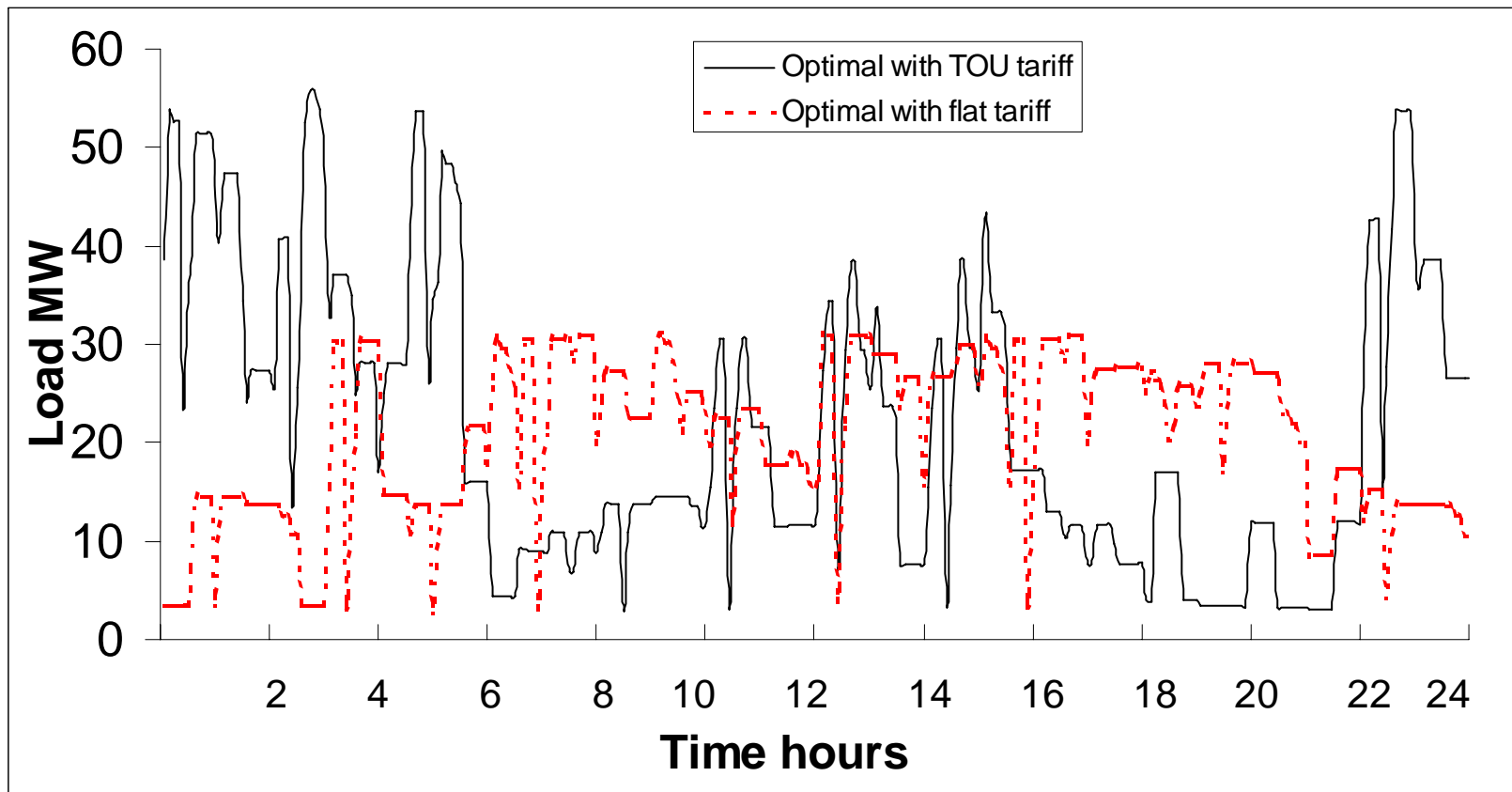



Process Scheduling Summary

Example	Structure	Results	Saving
Flour Mill Continuous	Linear, IP 120 variables 46 constraints	Flat- 2 shift - 25%store TOU-3 shift	1% 6.4% 75%peak reduction
Mini Steel Plant Batch	Linear, IP 432 variables 630 constraints	Flat TOU Diff loading	8% 10% 50% peak reduction



Cool Storage

- Cool Storage – **Chilled water** operate compressor during off-peak
- Commercial case study (BSES MDC), Industrial case study (German Remedies)
- Part load characteristics compressor, pumps
- Non- linear problem – 96 variables, Quasi Newton Method
- MD reduces from 208 kVA to 129 kVA, 10% reduction in peak co-incident demand, 6% bill saving

Cool Storage of Commercial Complex -under TOU tariff

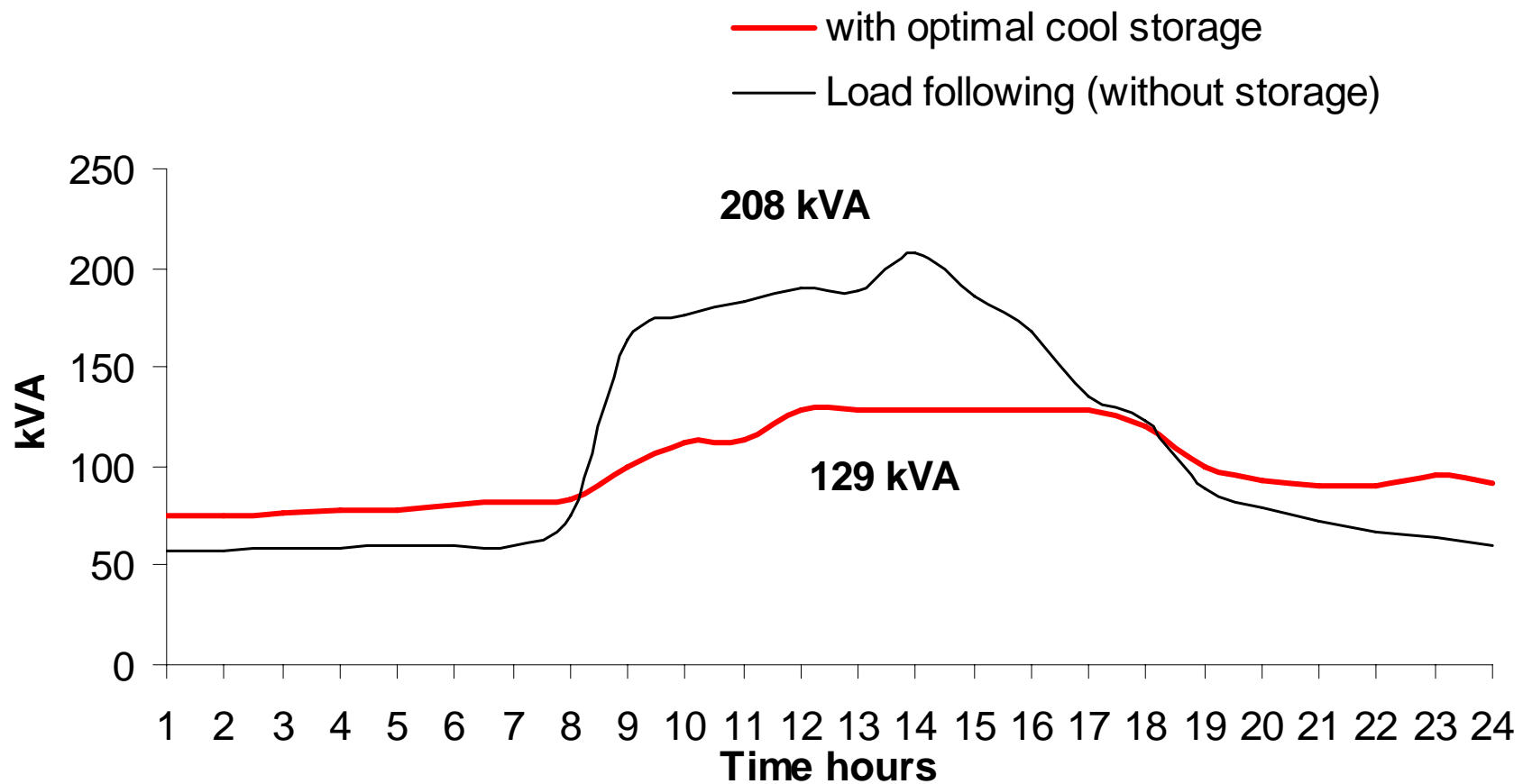



Cogeneration

- Process Steam, Electricity load vary with time
- Optimal Strategy depends on grid interconnection(parallel- only buying, buying/selling) and electricity,fuel prices
- For given equipment configuration, optimal operating strategy can be determined
- GT/ST/Diesel Engine – Part load characteristics – Non Linear
- Illustrative example for petrochemical plant- shows variation in flat/TOU optimal.

Willans Line

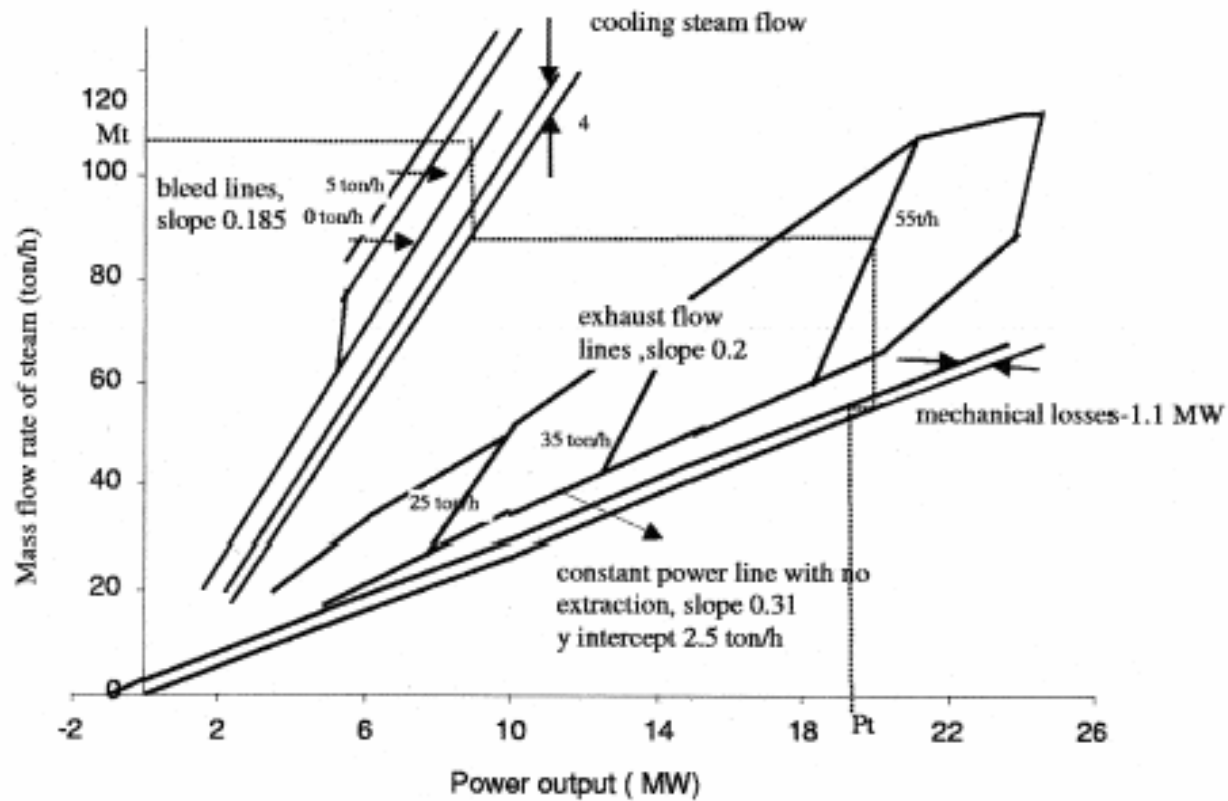

Cogeneration Example

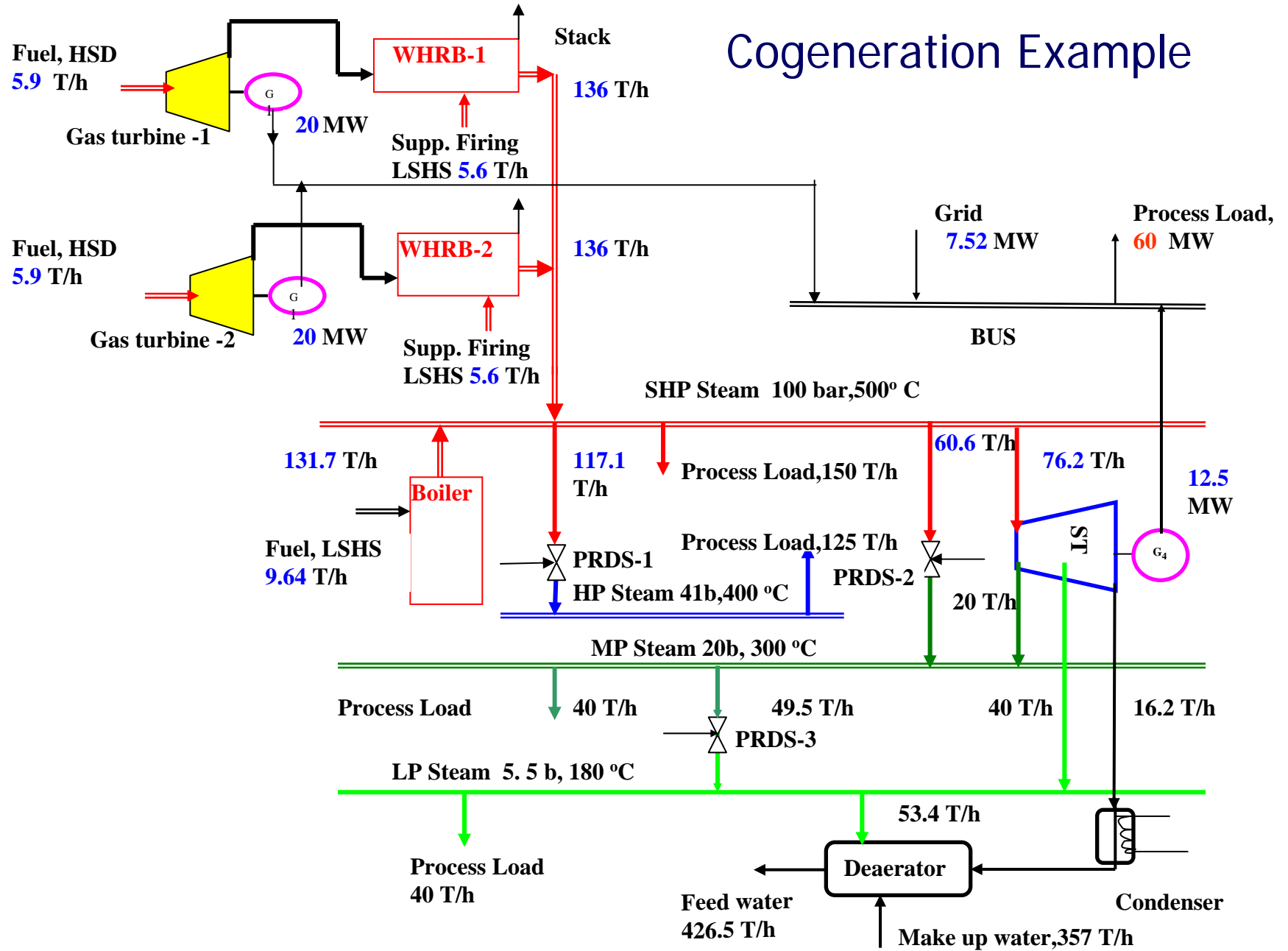

Import Power from Grid with Cogeneration for a Petrochemical Plant

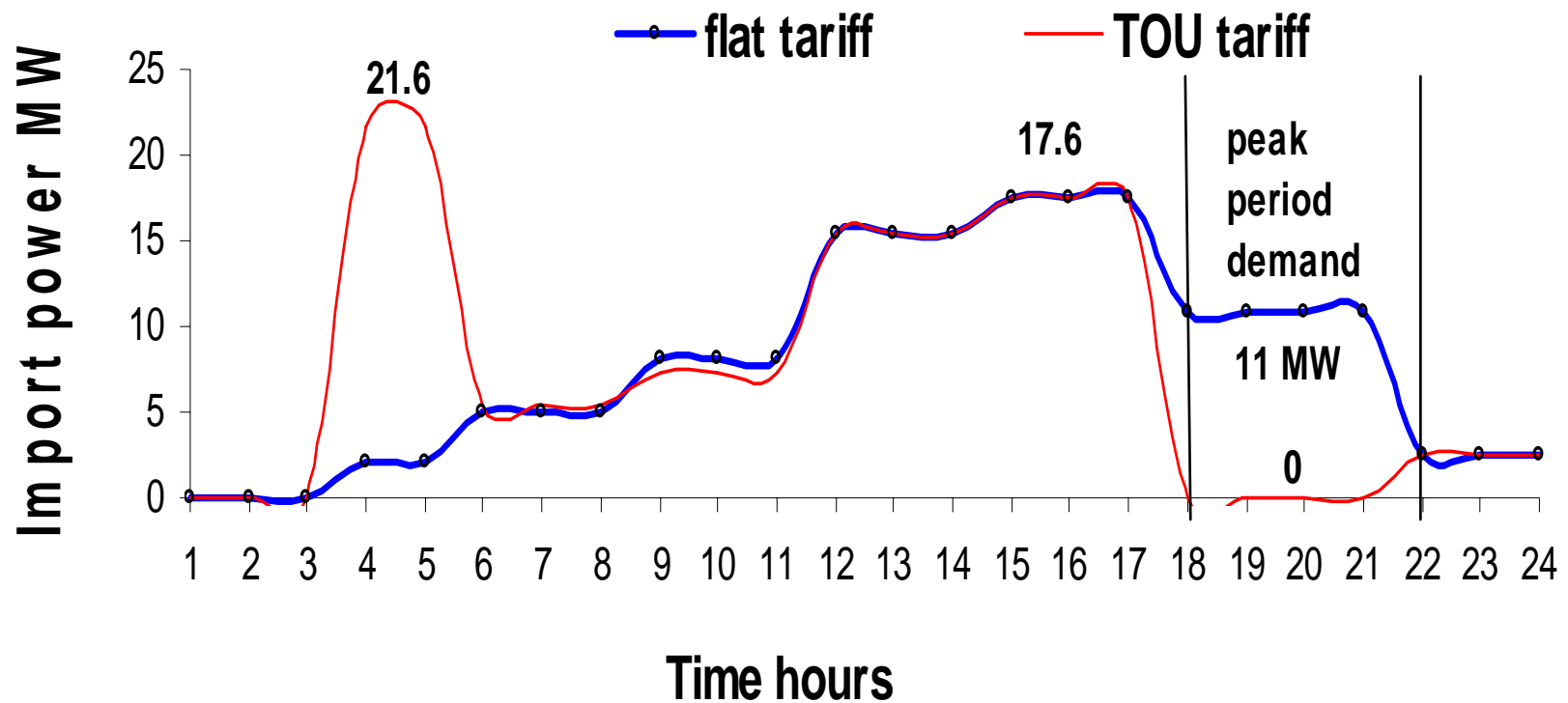

Export power to the grid with Cogeneration for a Petrochemical Plant

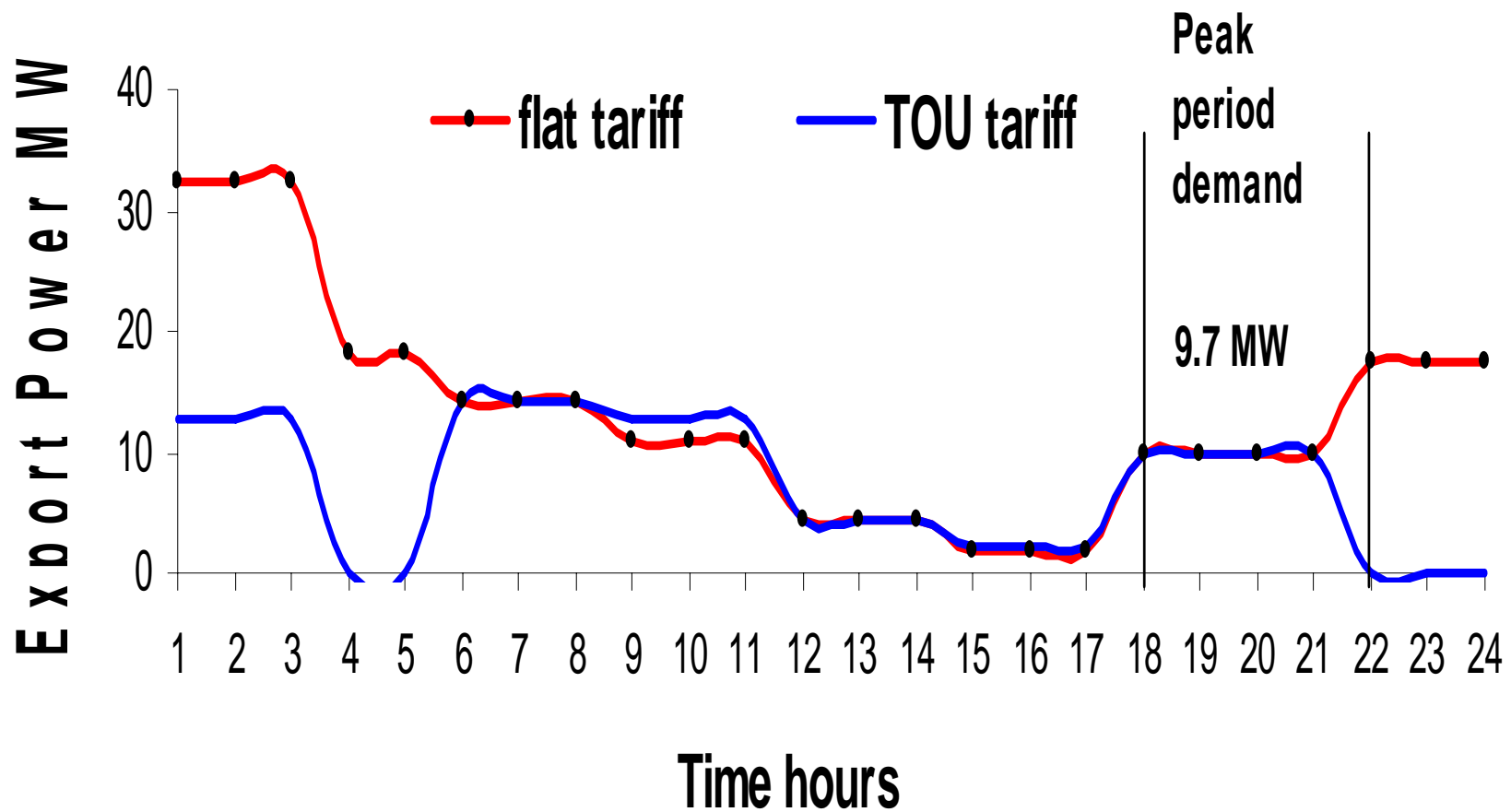

Industrial Load Management

- Integrated approach

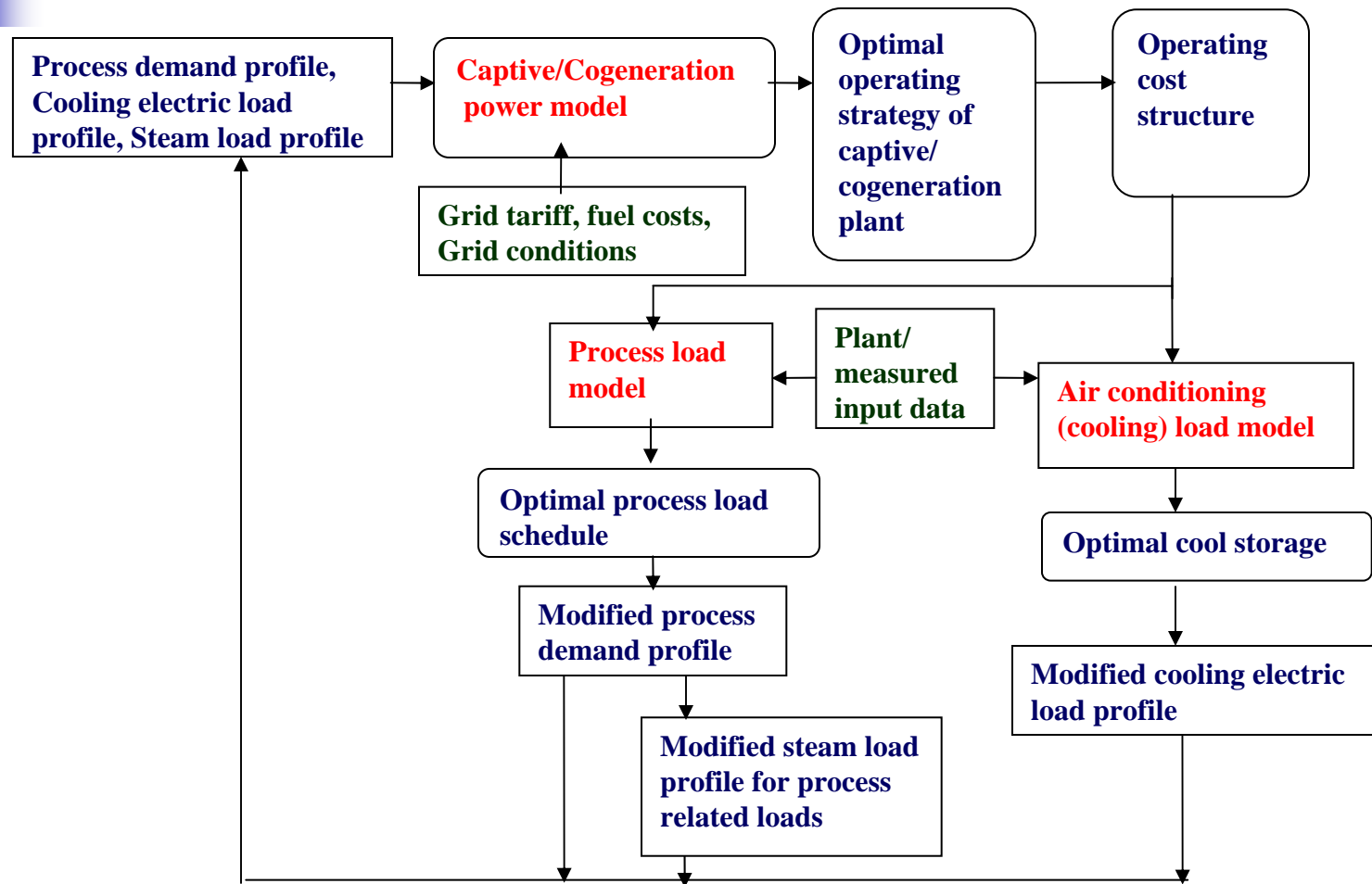

Glass furnace

Regenerator

Doghouse (raw material feeding section)

Melting end

Throat (processed glass outlet)

Working end

Checker work

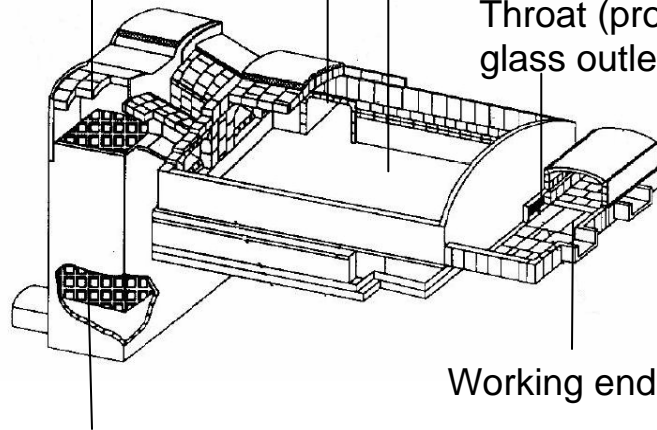

- Classification of furnace
 - Type of firing (Cross fired / end fired)
- Raw material
 - Batch material (like silica, soda ash etc.)
 - Cullet (recycled glass)
- Heat source
 - Flame direct contact with glass
- Minimum energy requirement
 - Heating of raw material up to reaction temperature
 - Endothermic heat of reaction for batch material



Modeling practices for glass furnace

- Continuum Process model
 - Commonly used
 - Glass furnace process in continuum equation
 - Three dimensional Navier-Stokes Equation and Hottel's zone method for radiation
- Process models used mainly troubleshooting and screening variables
- Limitations of process models
 - Data intensive inputs
 - Needs specialized skills and computational facilities to use
 - Energy performance not studied
 - Not easy to link operating parameters and impact on energy performance

Approach for study

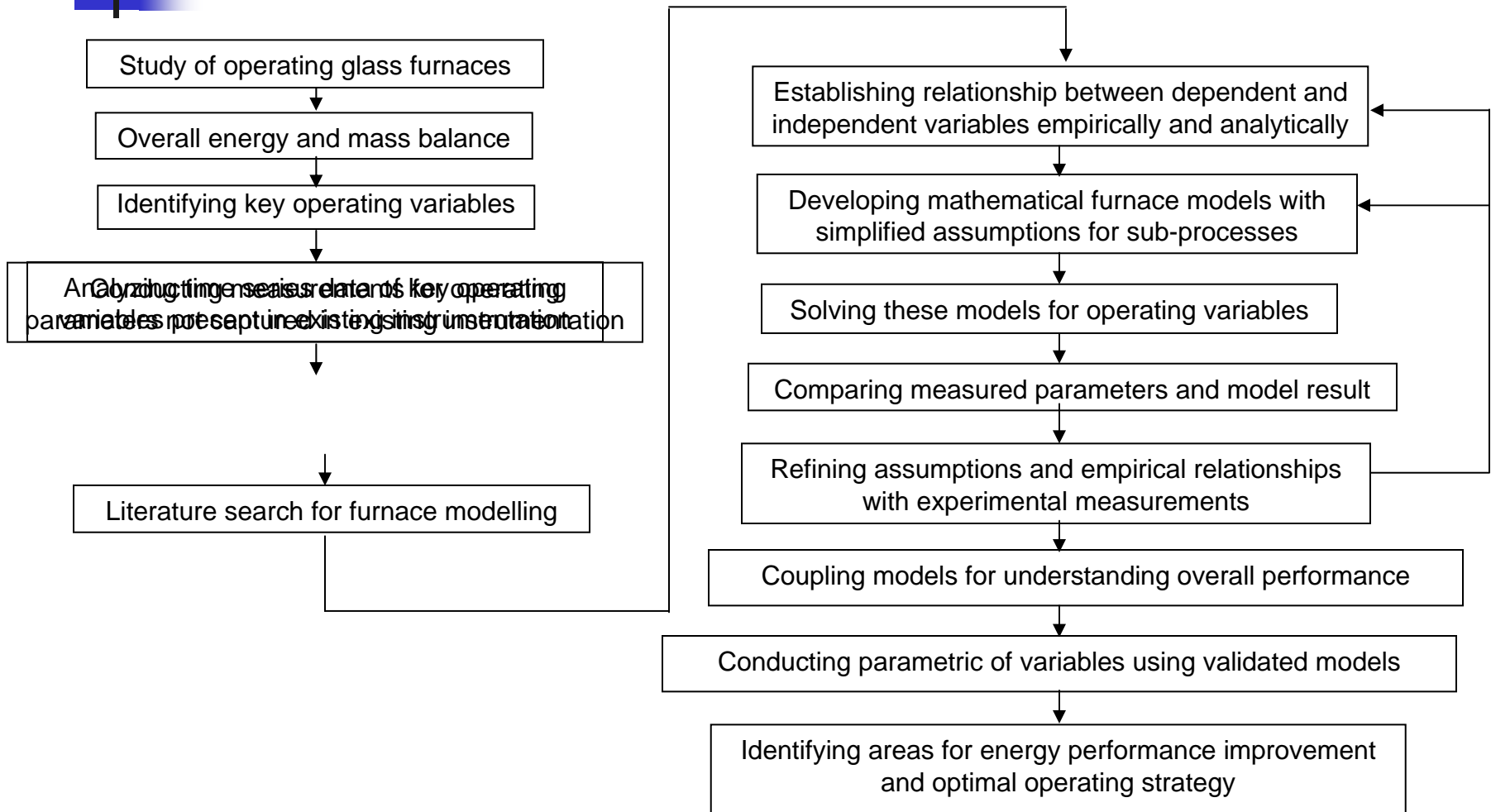

Control volume

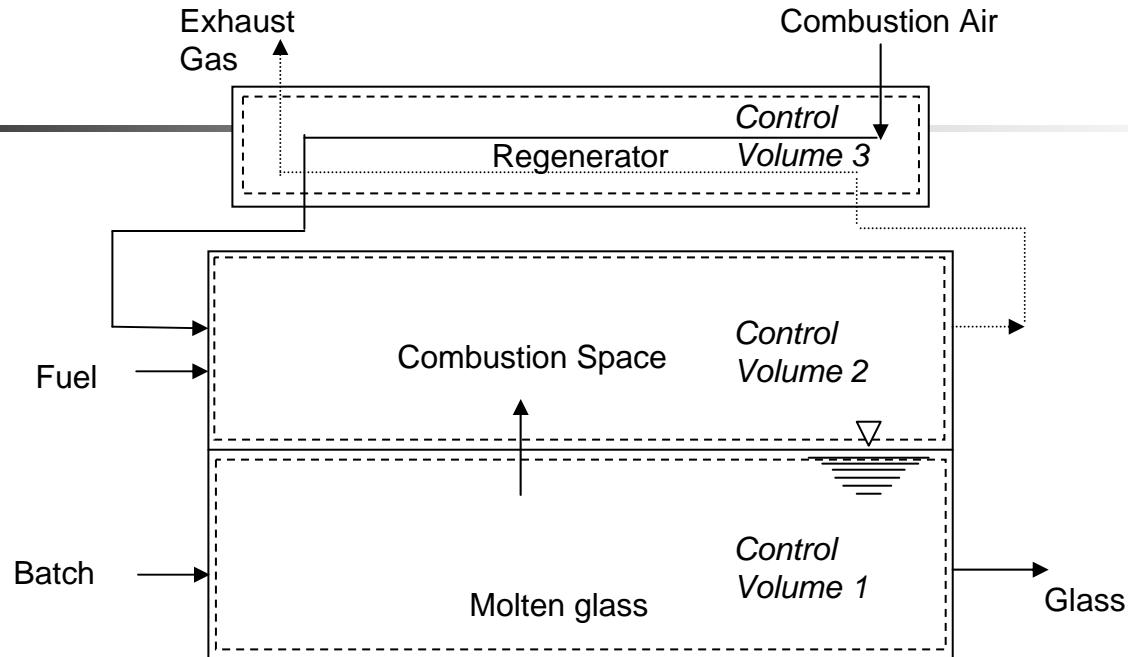

$$\dot{m}_{bh} \times h_{bh} + \dot{Q}_g = \dot{Q}_{l,wall,g} + \underbrace{\dot{m}_g \times h_g}_{\dot{Q}_{g,sensi}} + \underbrace{\dot{m}_g \times \sum h_{rk}}_{\dot{Q}_{g,rk}} + \underbrace{\dot{m}_{bh,f} \times h_{bh,f}}_{\dot{Q}_{bh,f}} + \underbrace{\dot{m}_w \times (h_{w,100^\circ C} + h_{w,lat})}_{\dot{Q}_w} \quad \text{Eq. 1}$$

$$\underbrace{\dot{m}_{fu} \times CV}_{\dot{Q}_{fu}} + \underbrace{(\dot{m}_{comb,air,nonreg} + \dot{m}_{noncomb,air,nonreg}) \times h_{air,\infty}}_{\dot{Q}_{air,nonreg}} + \underbrace{\dot{m}_{air,comb,reg} \times h_{air,comb,reg}}_{\dot{Q}_{air,reg}} = \dot{Q}_{l,wall,comb} + \dot{Q}_g + \underbrace{\dot{m}_{tot,f} \times h_f}_{\dot{Q}_{l,reg,f}} \quad \text{Eq. 2}$$

$$\dot{m}_{f,tot,in} \times h_{f,in} + \dot{m}_{air,leak,reg} \times h_{air,leak} = \dot{m}_{f,tot,out} \times h_{f,out} + \dot{Q}_{l,wall,reg} + \dot{m}_{air,comb,reg} \times (h_{air,comb,reg,out} - h_{air,comb,reg,in}) \quad \text{Eq. 3}$$



Mass balance of furnace

- Input streams

- Batch material
 - Cullet (recycled glass)
 - Raw material
 - Moisture
- Fuel
- Combustion air (from regenerator)
- Air leakage (Any air other than inlet from regenerator)

- Output streams

- Molten glass
 - Cullet
 - Glass from raw material
- Flue gas to regenerator
 - Combustion products
 - Glass reaction products
 - Water vapors
 - Air (Not reacted in combustion)
- Flue gas leakage from furnace

Mass balance estimation

Estimation of flue gas formation

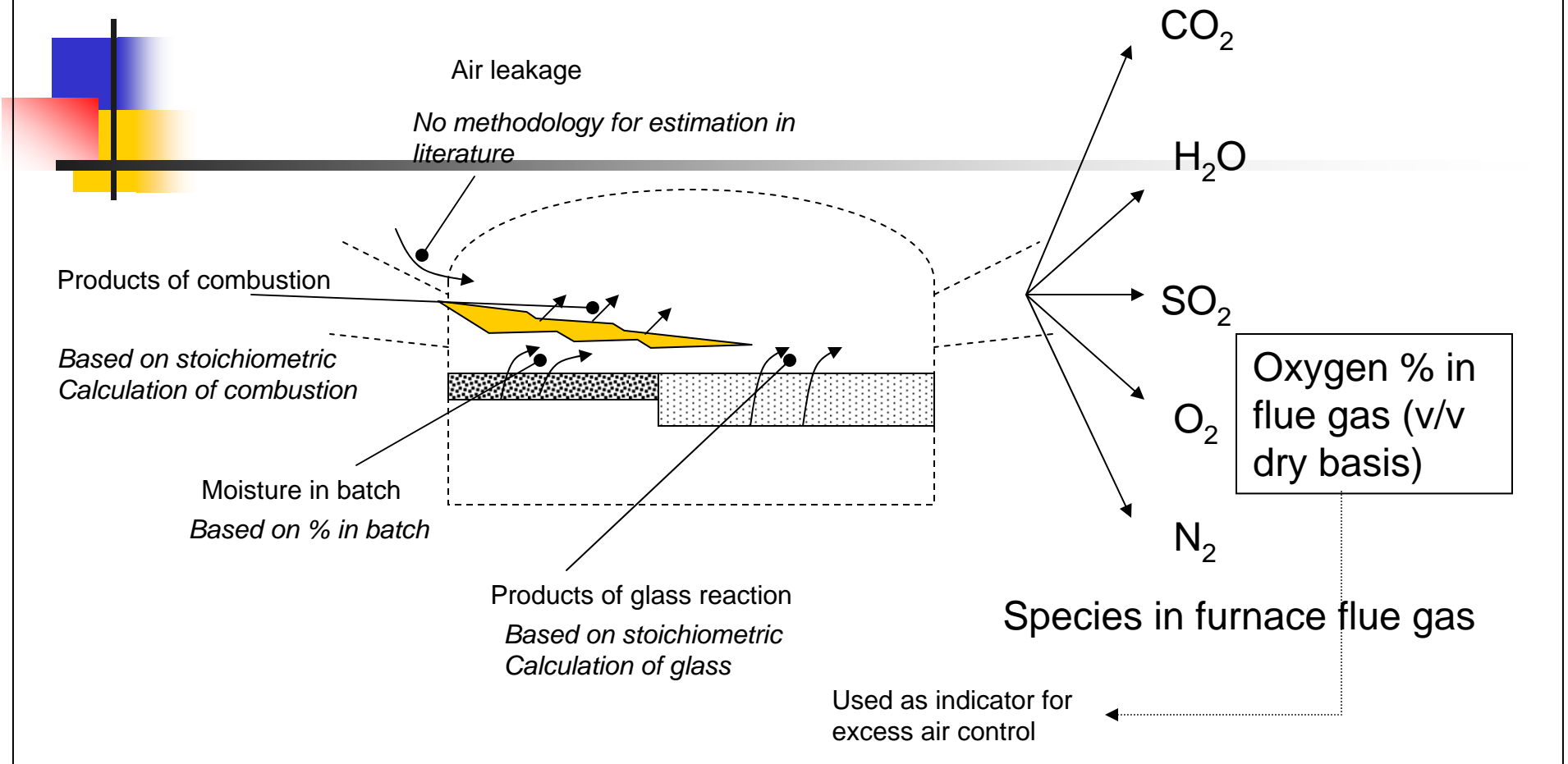

Air leakage estimation

- Furnace operates positive pressure
 - Air leakage in local negative pressure area
 - Air leakage due to higher pressure on air side
 - Air supplied for atomization and flame length control

Air for fuel atomization / flame control during firing and tip cooling air during non firing

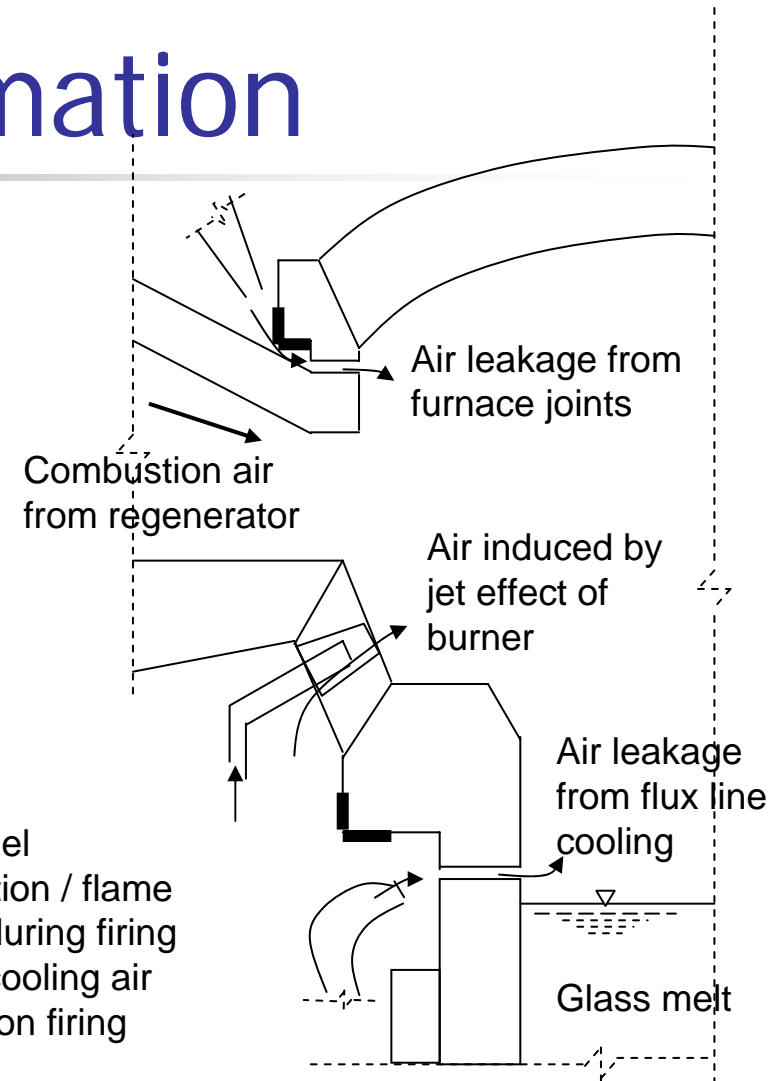



Energy balance for furnace

- Input streams

- Energy from fuel
- Energy from preheated combustion air
- Energy from batch material
- Energy from air leakage

- Output streams

- Energy carried in glass
 - Heat of reaction
 - Sensible heat of glass
- Energy carried in flue gas
 - Energy for air leakage
 - Energy for batch gases
 - Energy for moisture
 - Energy for combustion air
- Energy loss from walls
 - Surface heat loss from walls
 - Radiation losses (due to opening)

Energy balance glass melt

- Heat of reaction for glass
- Heat carried by glass
- Heat carried by batch gas

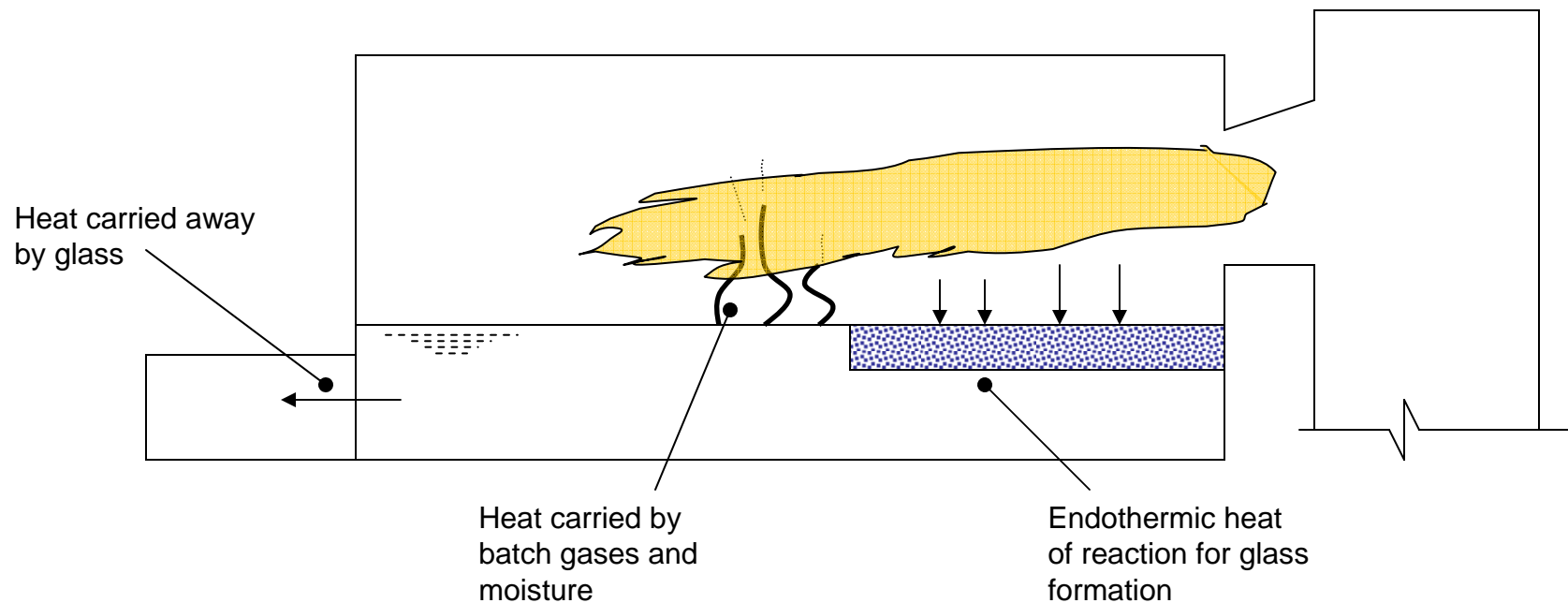

Furnace wall losses

Zones along furnace crown and superstructure side wall length

Flux line

Zones along furnace sidewall depth

Zones along furnace melter sidewall length

Glass flow direction

Molten Glass

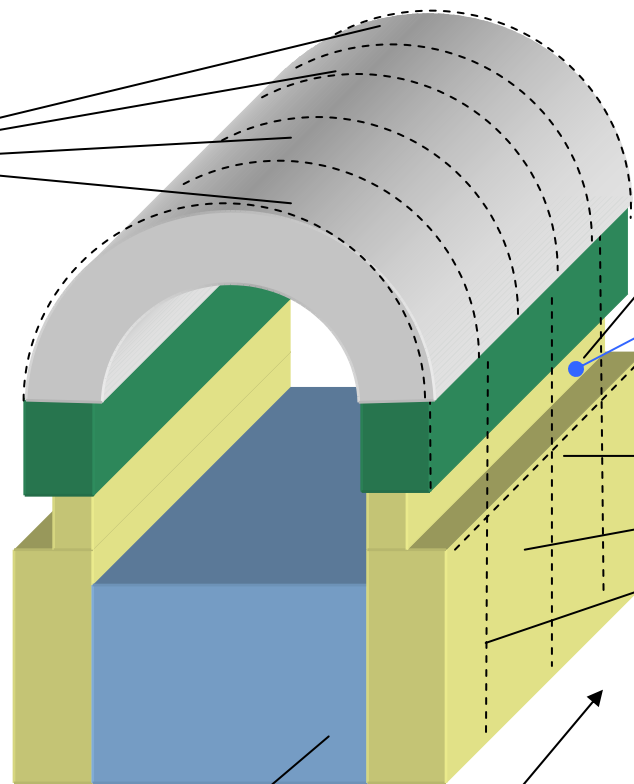



Furnace model input parameters

- Design parameter
 - Design capacity of furnace
 - Melting area
 - Length to width ratio
 - Height of combustion volume
 - Refractory and insulation details
- Operating parameters
 - Furnace draw
 - Type of fuel
 - Batch to cullet ratio
 - Moisture in batch
 - Furnace pressure
 - Oxygen at furnace outlet
 - Atomization pressure
 - Reversal time
 - Flux-line and burner tip cooling air pressure

Model flow diagram

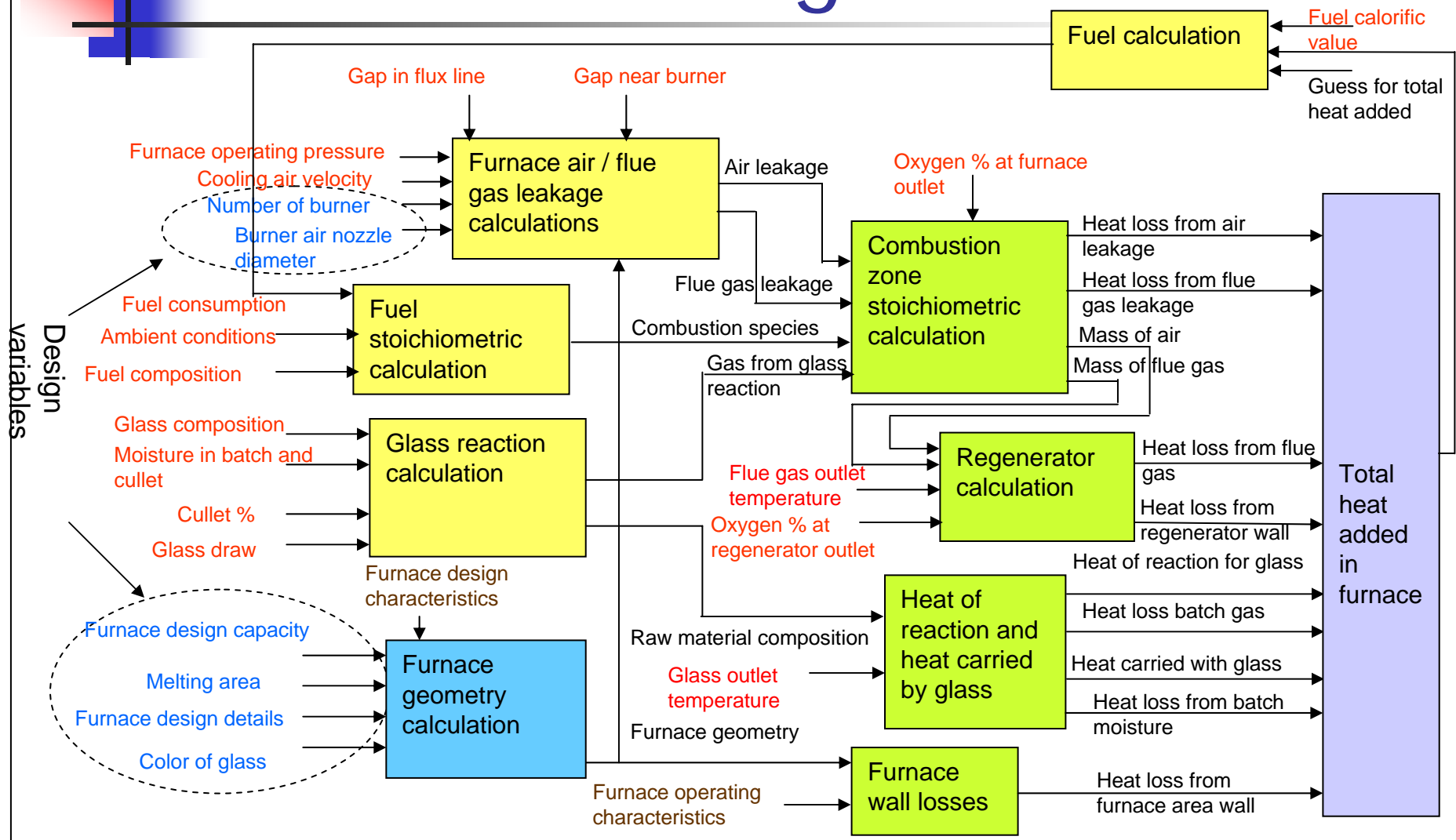

Furnace measurement

Measurement location	Type of measurement
1	Oxygen % , Pyrometer checkers surface temperature
2	Oxygen % , Flue gas temperature
3	Oxygen % , Flue gas temperature
4	Oxygen % , Skin temperature
5	Pyrometer checkers surface temperature
6	Velocity of air at the suction of blower
7	Outside wall temperature for crown and side wall
8	Pyrometer glass surface temperature

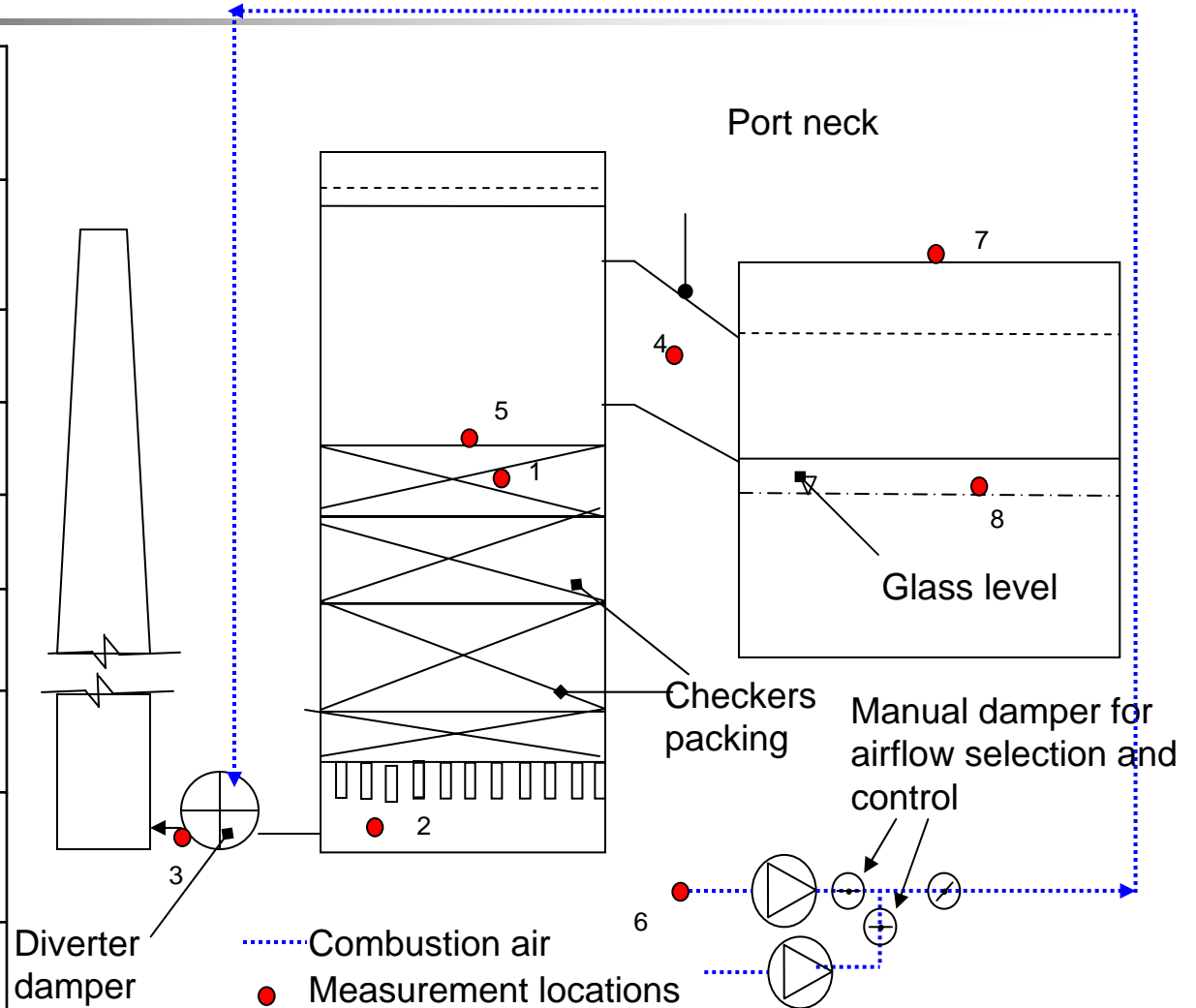

Model results: Actual SEC

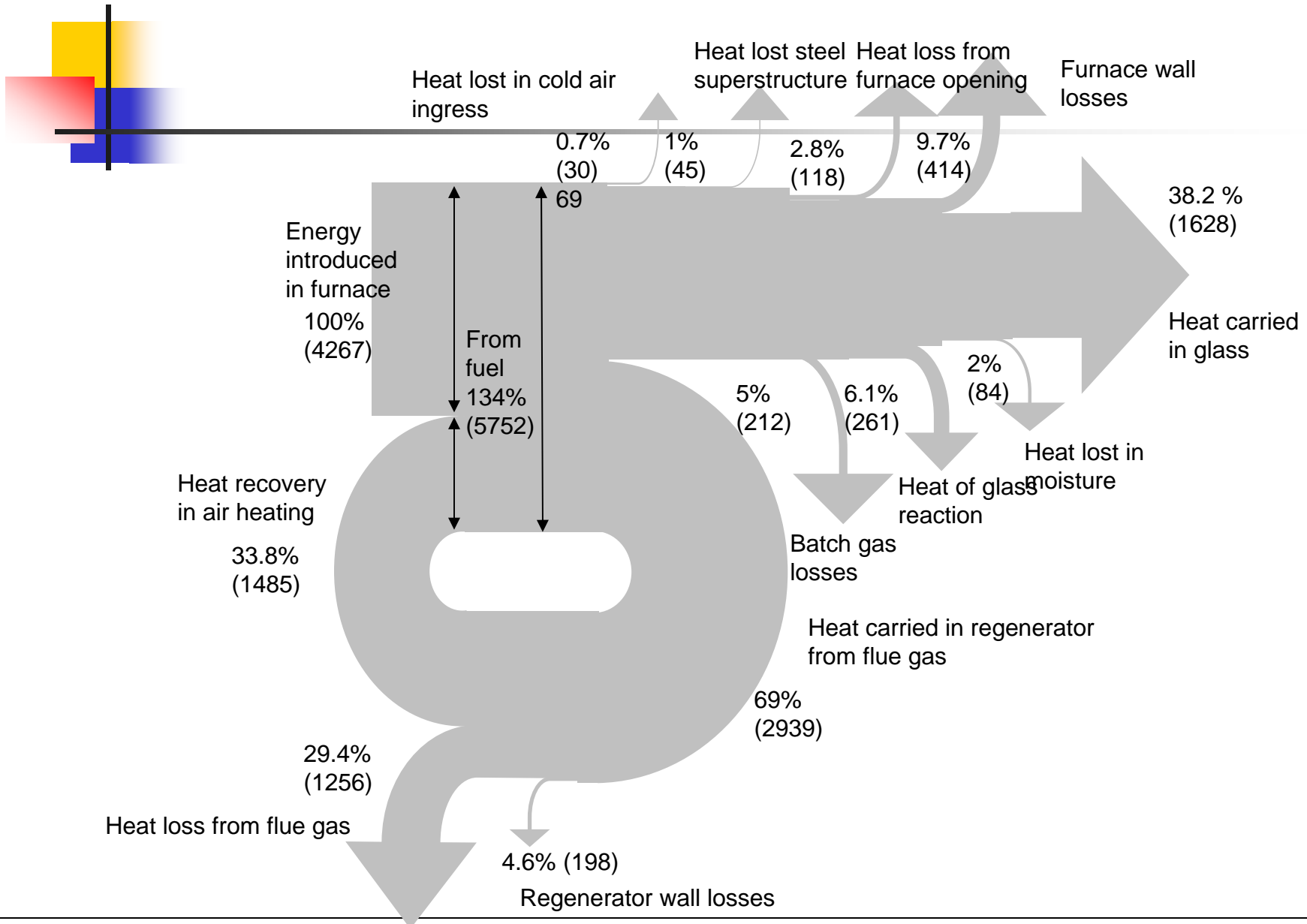

Model results: Target SEC

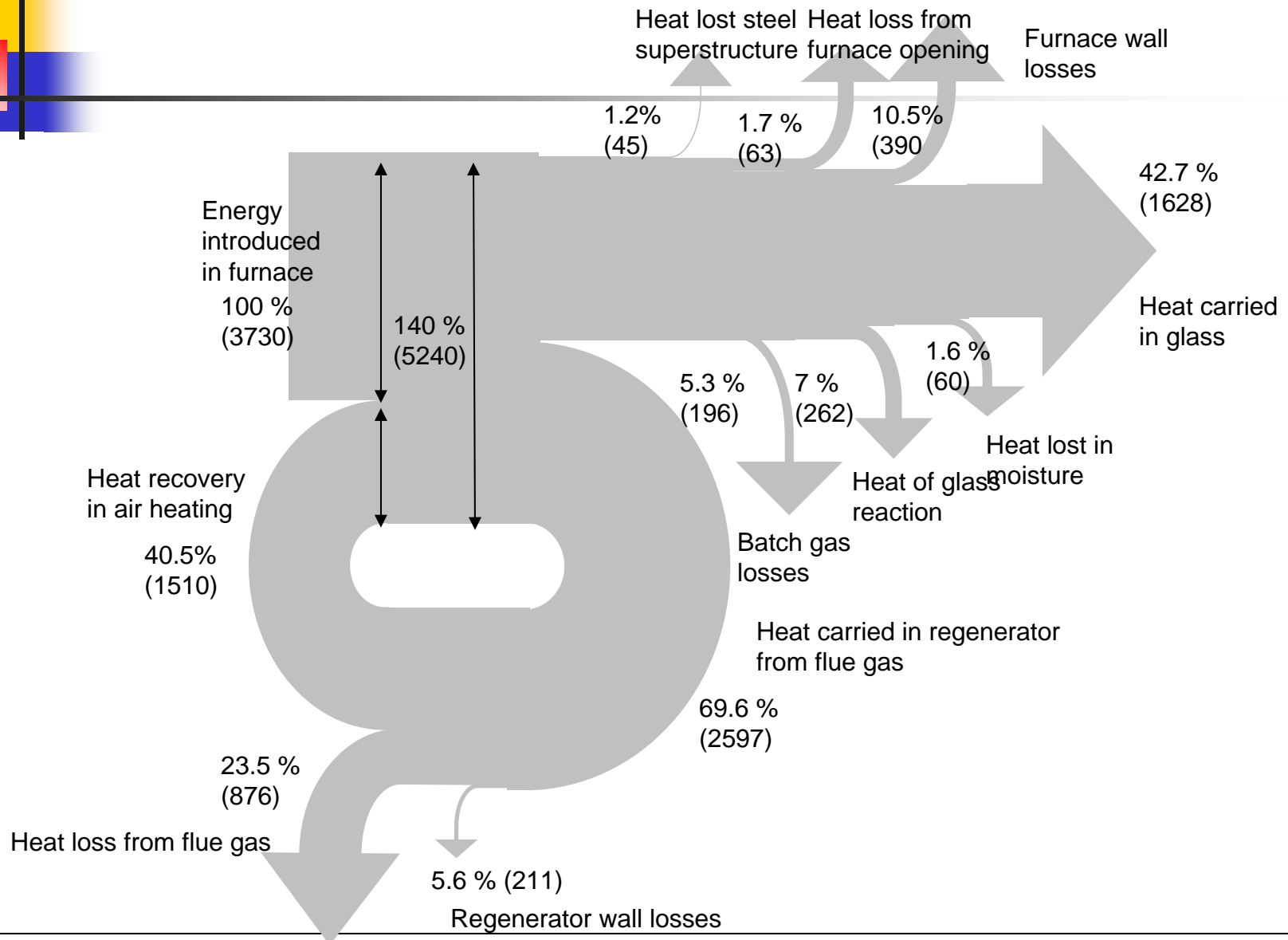

Conclusions

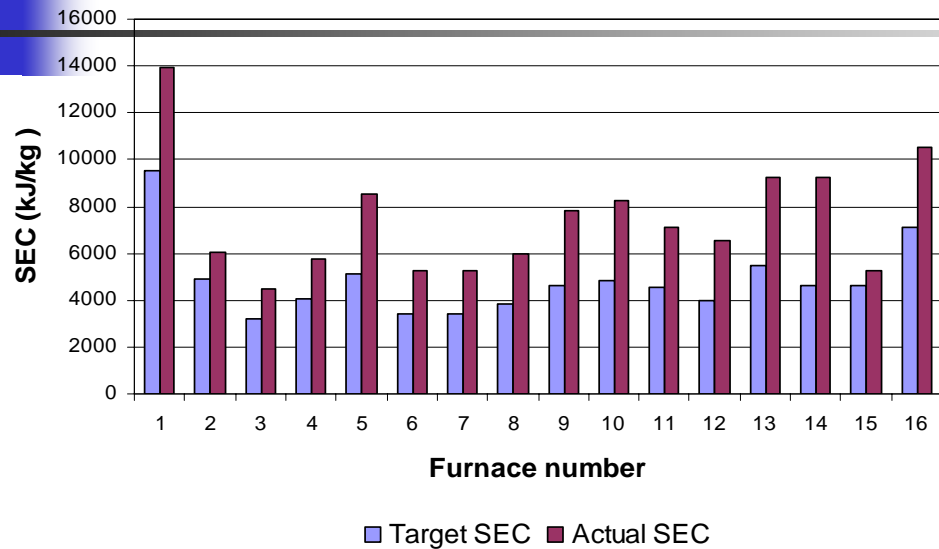

- Target SEC estimated for 16 industrial furnaces
- Effect of furnace draw on target SEC is demonstrated

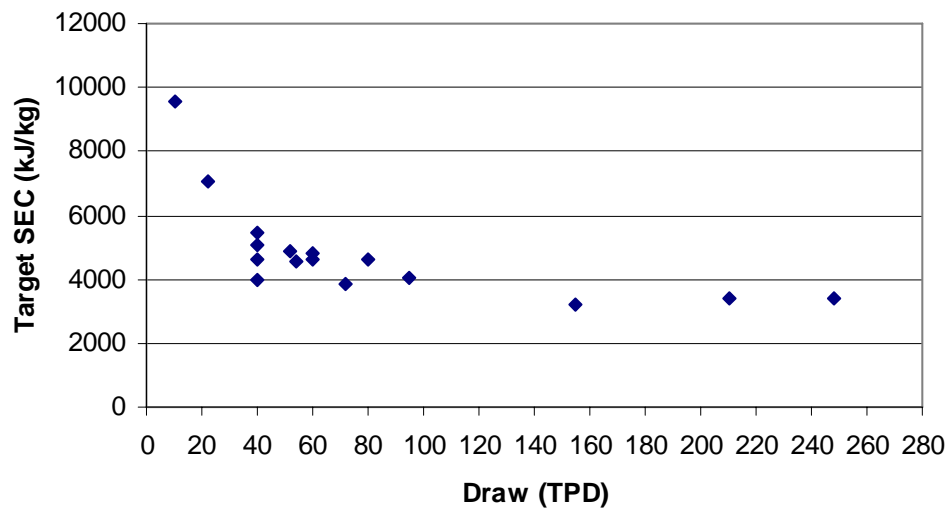

Generalized approach for model based benchmarking

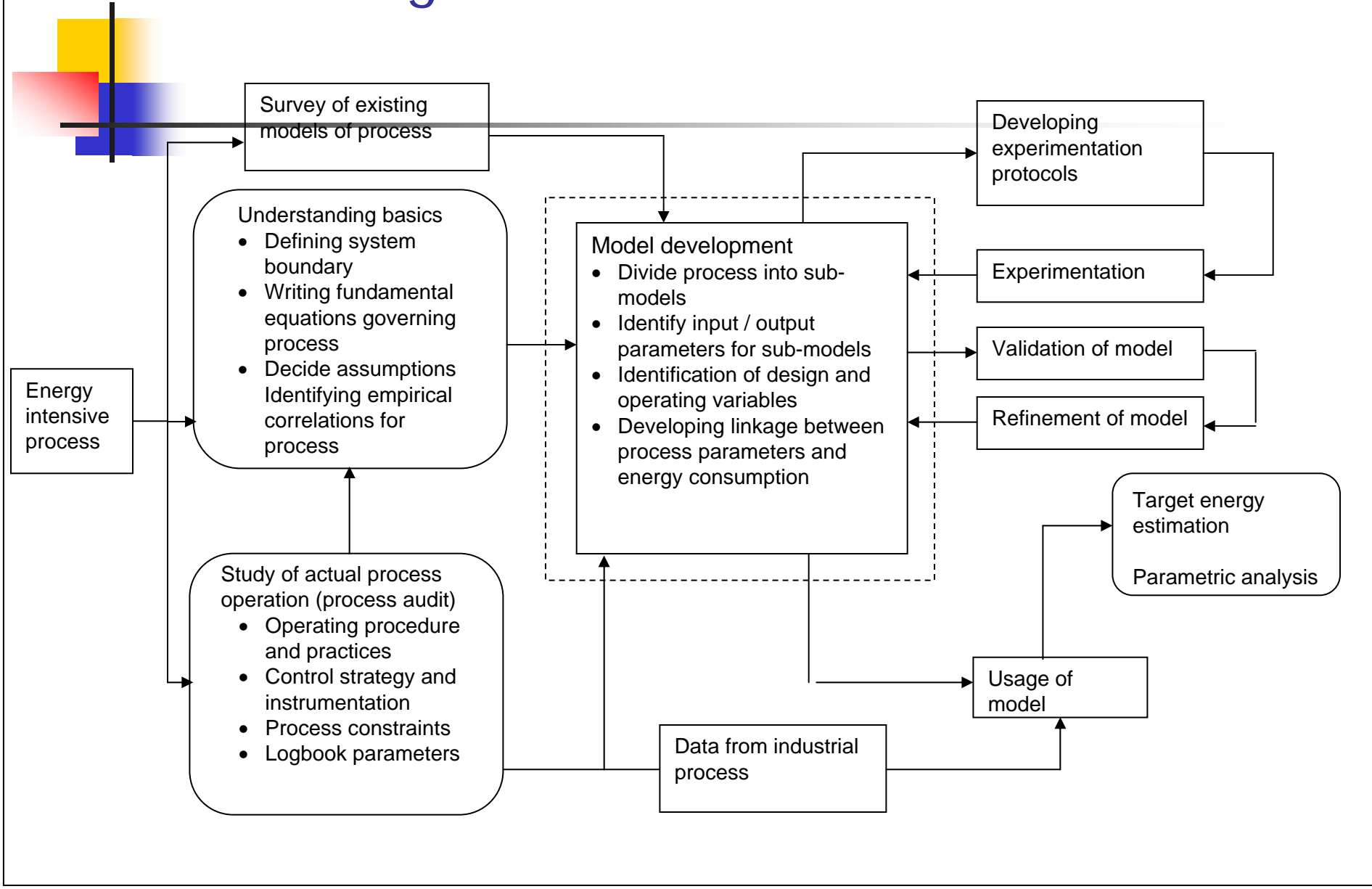

Sizing of Photovoltaic-Battery Systems

Objective:

- To arrive at the set of all feasible configurations (Array rating and Battery capacity) to meet a given demand following a time-series simulation of the system

Schematic of the System

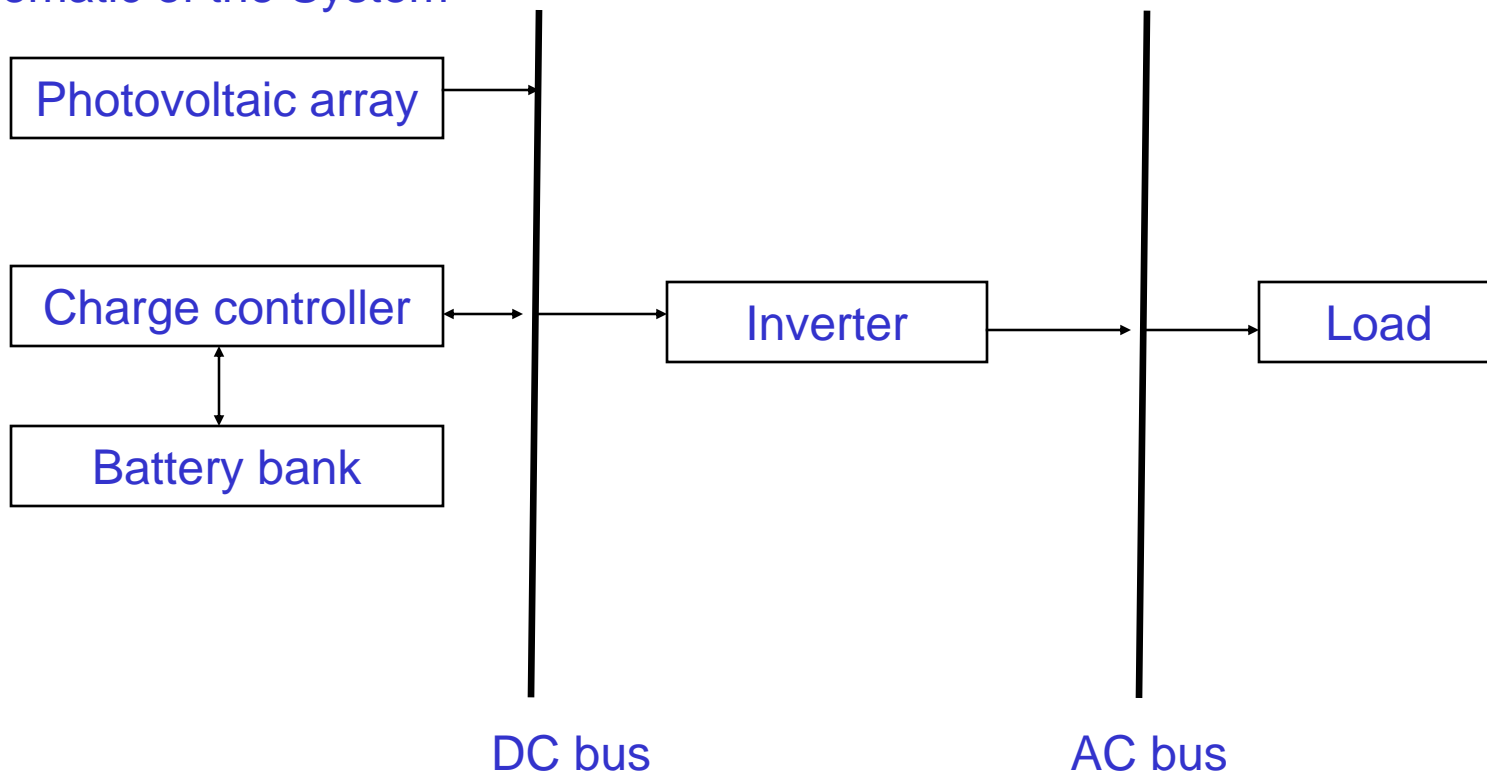

Mathematical model

➤ Energy balance

$$\frac{dQ_B}{dt} = (P_P(t) - D(t))f(t)$$

Power from the photovoltaic array

➤ For a small time step, battery energy:

$$Q_B(t + \Delta t) = Q_B(t) + (P_P(t) - D(t))f(t)\Delta t$$

Hourly energy balance

$$Q_B(t = 0) = Q_B(t = T)$$

Repeatability of battery energy

$$Q_B(t) \geq 0$$

Non negativity of battery energy

$$B_r = \frac{\max\{Q_B(t)\}}{DOD}$$

Battery storage requirement

Photovoltaic-Battery System Sizing (Deterministic Approach)

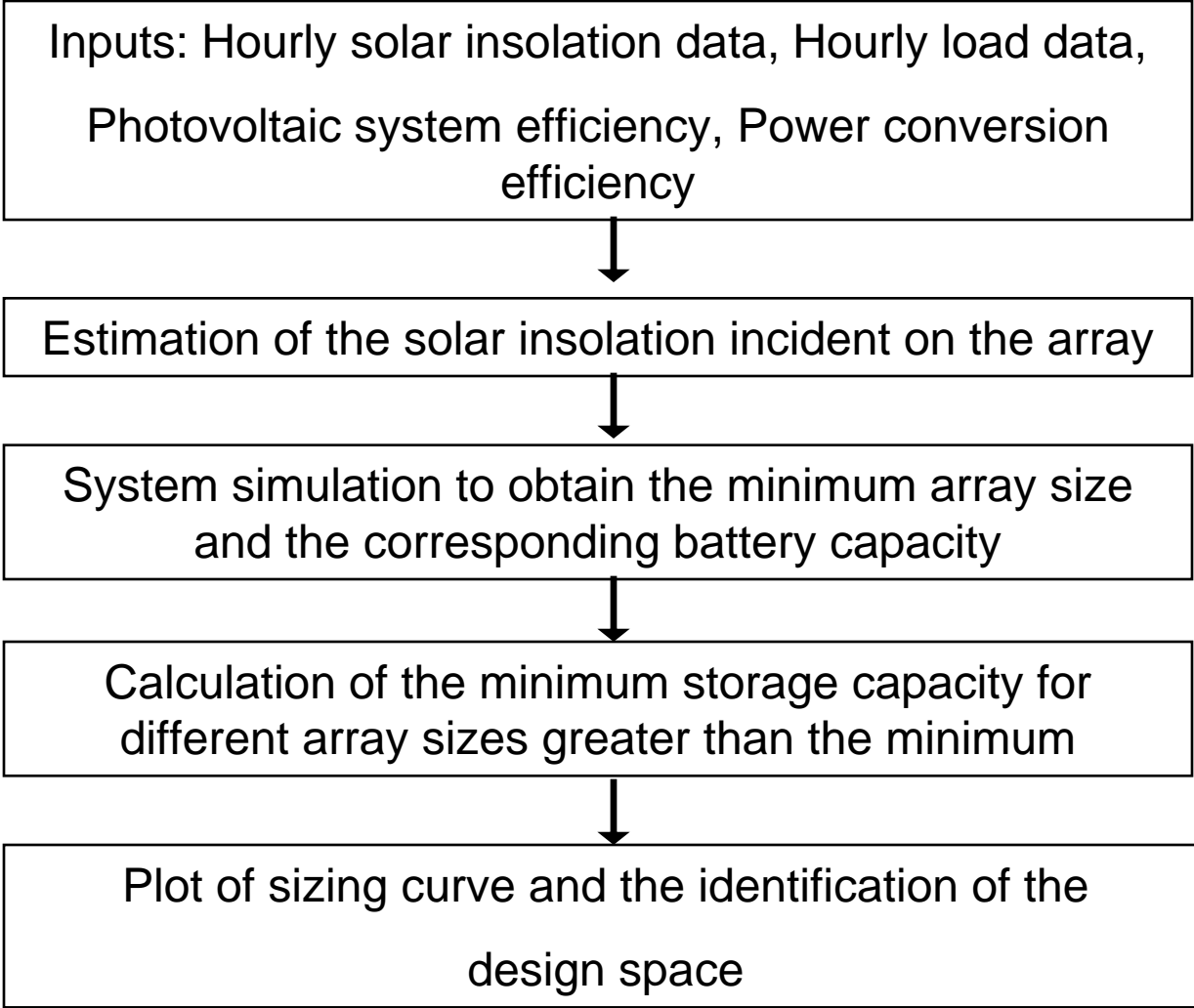

Graphical representation

- Sizing curve for given solar insolation profile, load curve and system characteristics

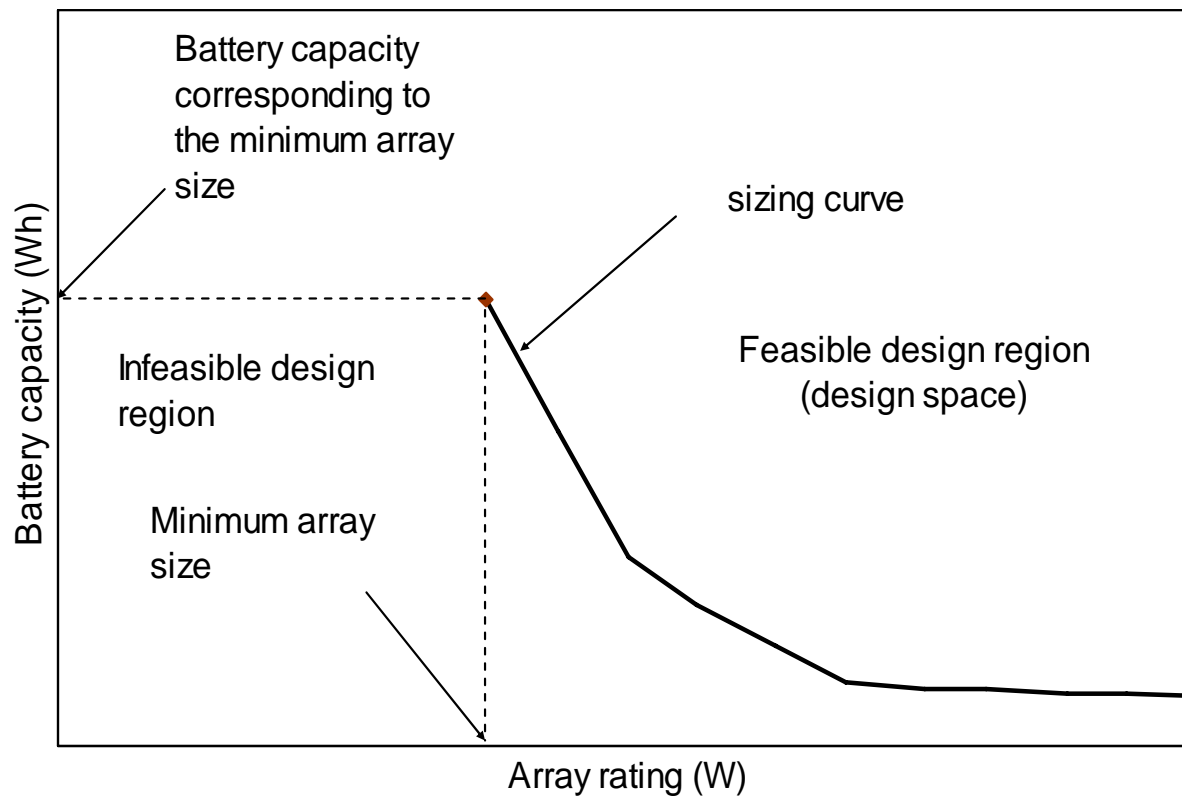

Photovoltaic-Battery System Sizing (Example)

For a remote location in Sagar island, West Bengal

➤ Solar insolation profile

Averaged values for the month of December

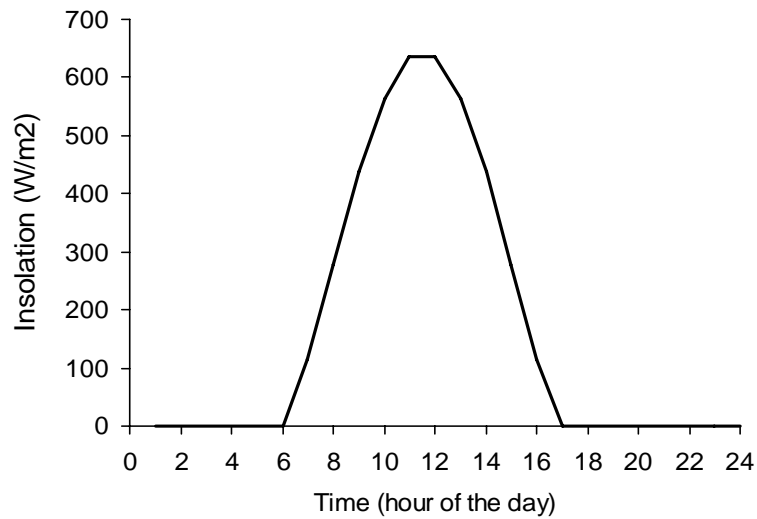

➤ Demand profile

For an average day

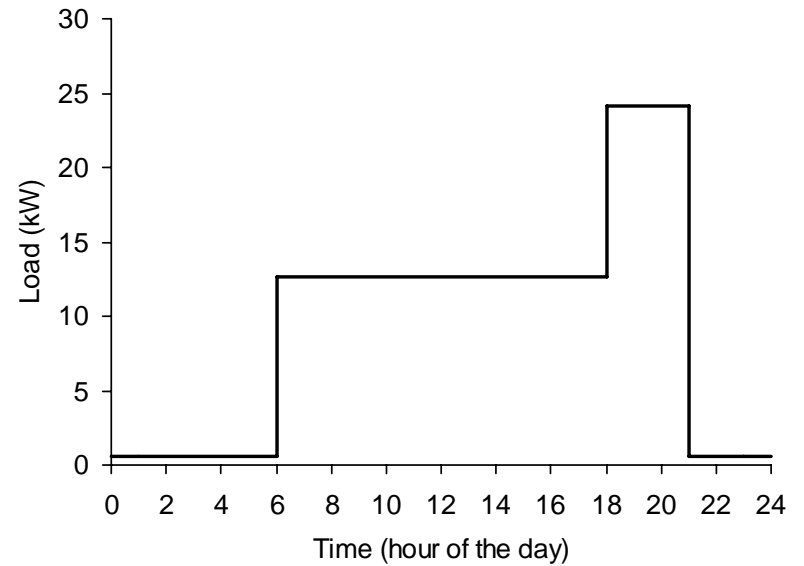

Sizing curve and Design-space for the example

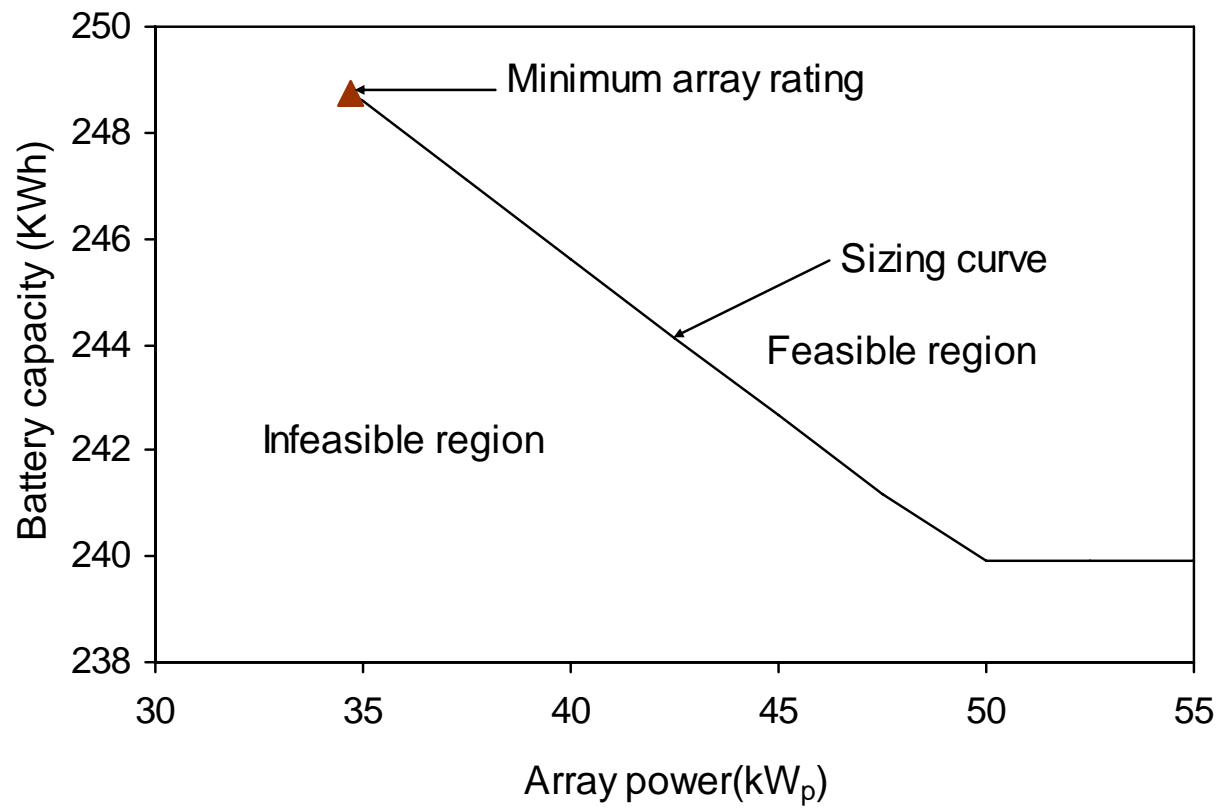



Energy Planning Research Objective

- Energy Planning - Aggregated at National Level
- Sectoral Planning - Oil, Electricity
- Limited Efforts in Local Level Energy Planning
- Energy critical input for development
- Need for micro level energy planning

Objective: Develop a tool for improving local level energy decisions



DSS Modules

- Energy Models in Literature – aggregate , homogenous unit, optimisation, no linkage with decision structure
- Study of decision structure, proposed an accounting framework
- Disaggregation by sector, end-uses
- DST-UNDP project – Bankura district in West Bengal

Analysis **District level – with block as an unit**
Block level- with village as an unit



Energy decisions for district officials

District Magistrate	Ratifying departmental decisions
Zilla Parishad Sabadhipati	Sanctioning/selecting schemes
Manager, DIC	Sanctioning industries, biogas plant, Priority list of industries.
DE, WBSEB/Addnl CE (Rural Elec)	Mouza electrification
Controller food, civil supplies	Distribution of kerosene, coal.
Lead Bank Officer	Preparation of District credit plan
District forest Officer (DFO, working plan)	Managing forest area
District Planning Officer	Prepares district plan



Typical Energy Decisions

- **District** – Fund Allocation to blocks, Mouza electrification, Industrial devpt., Coal – elect., fuel / ration shops Sanctions.
- **Block**– Fund Allocation to GPs, Kerosene allocation, industry promotion, marketing support.
- **Gram Panchayat** – Agriculture / irrigation schemes, Co-op industry, request for fuel/ration shop, electricity.
- **Household** – Fuel choice, Device choice.

DSS Frame Work

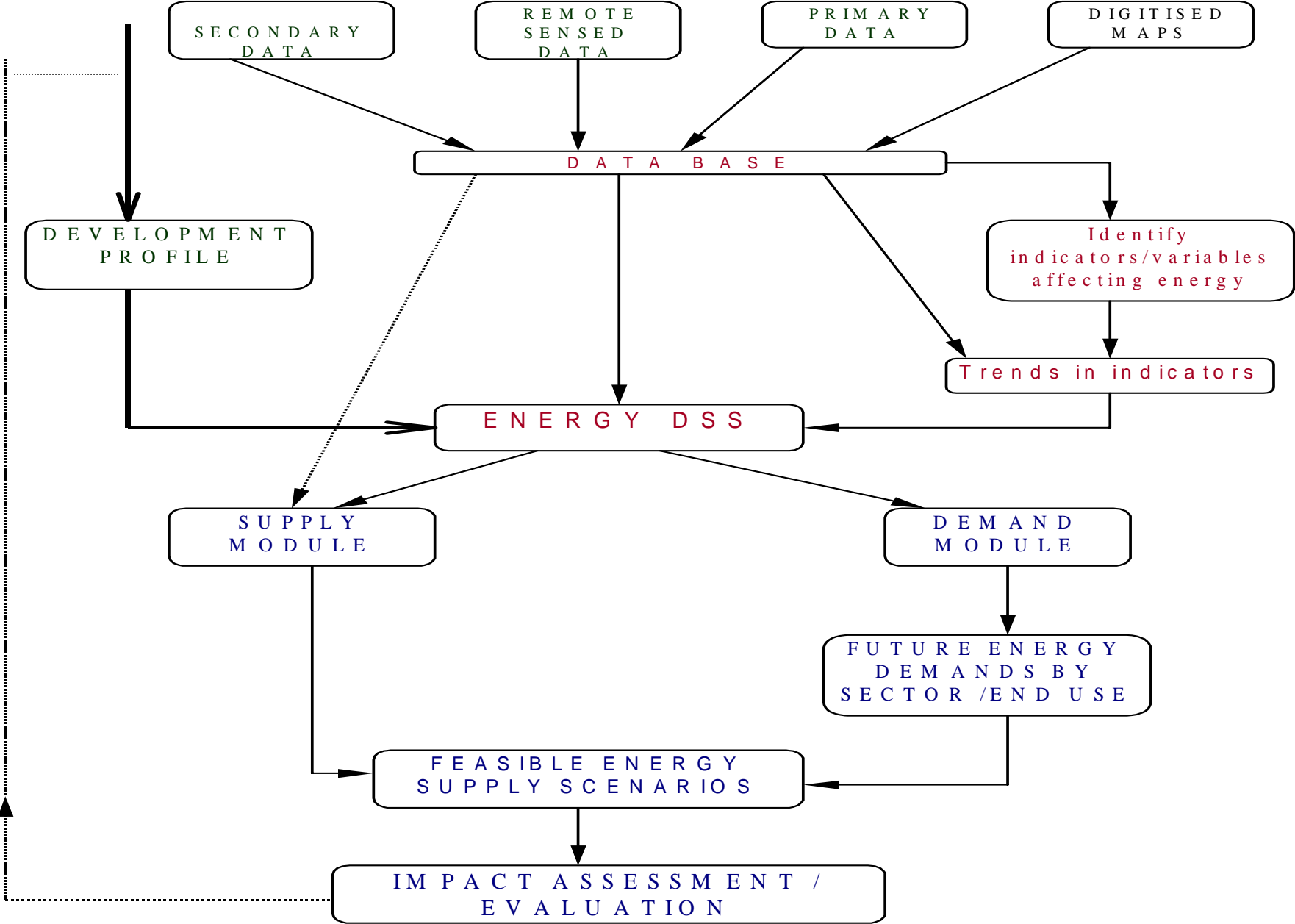

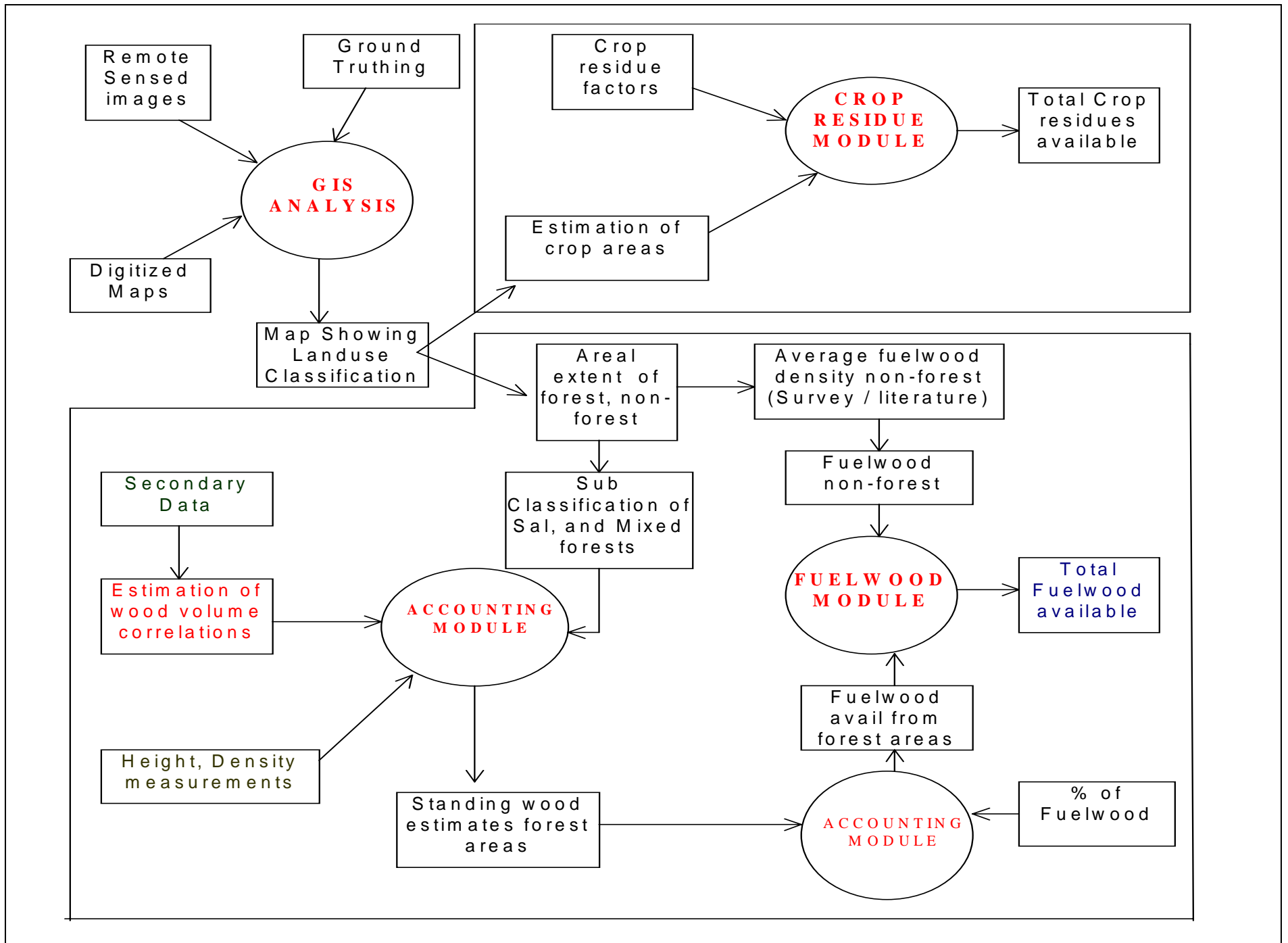

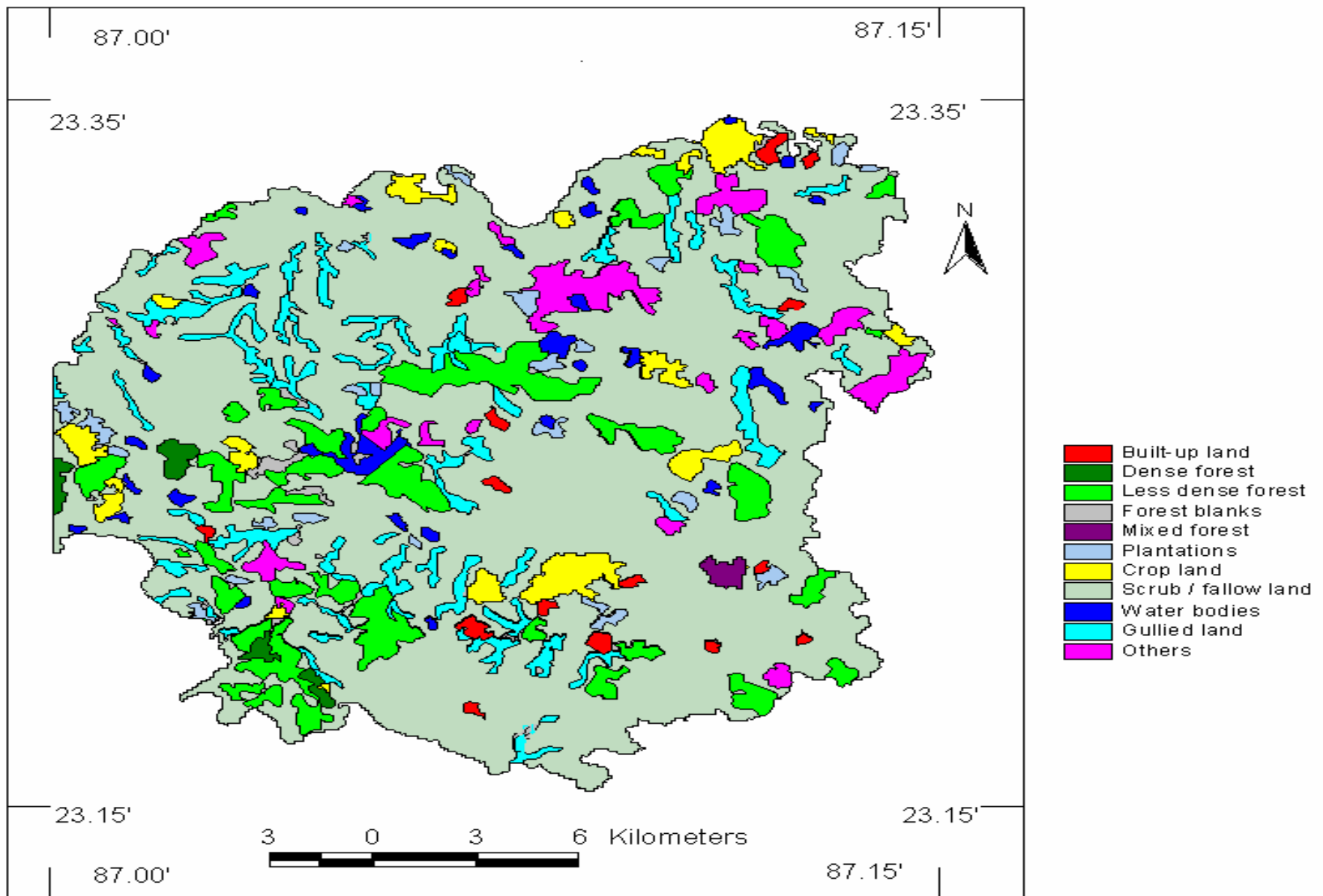

Source: IRS-1B LISS-II Satellite data(28.Feb.96)

Landuse / landcover map of Gangajalghati block, Bankura district



Drivers for Demand Scenarios

	Residential cooking	Residential Non-cooking	Agriculture	Industrial
Drivers	Population Low-Med-High (L-M-H) Income No Transition(NT)/ Transition(T)	Population (no of Households) Low-Med- High (L-M-H) Income NT-T Electrification NE-ME-AE	Rainfall Low-Med-High LR – MR – HR Irrigation NI – LI- MI – HI Crop Pattern NTC/TC1/TC2 Pump Electric NE/ME/AE	Growth Low-Med-High LG/MG/HG *Rice mills linked to agricultural scenarios
No of combinations	6	18	108	3+

Select Scenario cases

	Population	Income	Village Electrification	Rain	Irrigation Land	Crop Pattern	Pump Electrified	Ind. Growth
SC1	L	NT	NE	HR	NI	NTC	NE	LG
SC2	H	T	AE	LR	HI	TC2	AE	HG
SC3	M	T	ME	MR	MI	TC2	ME	MG
SC4	L	T	AE	HR	HI	TC1 TC2	AE	HG
SC5	L	T	ME	HR	MI	TC1	ME	MG



Electricity Demand in 2005

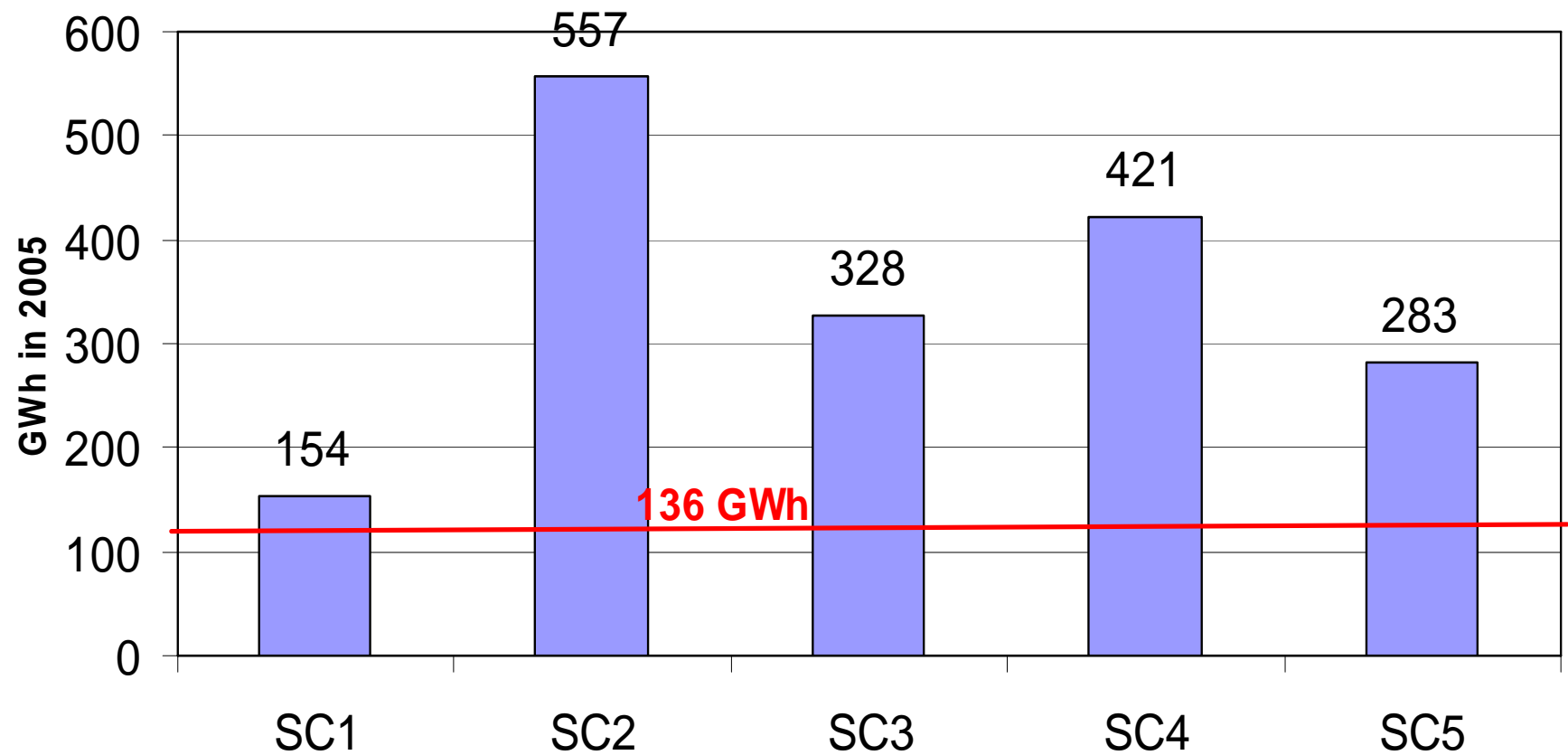

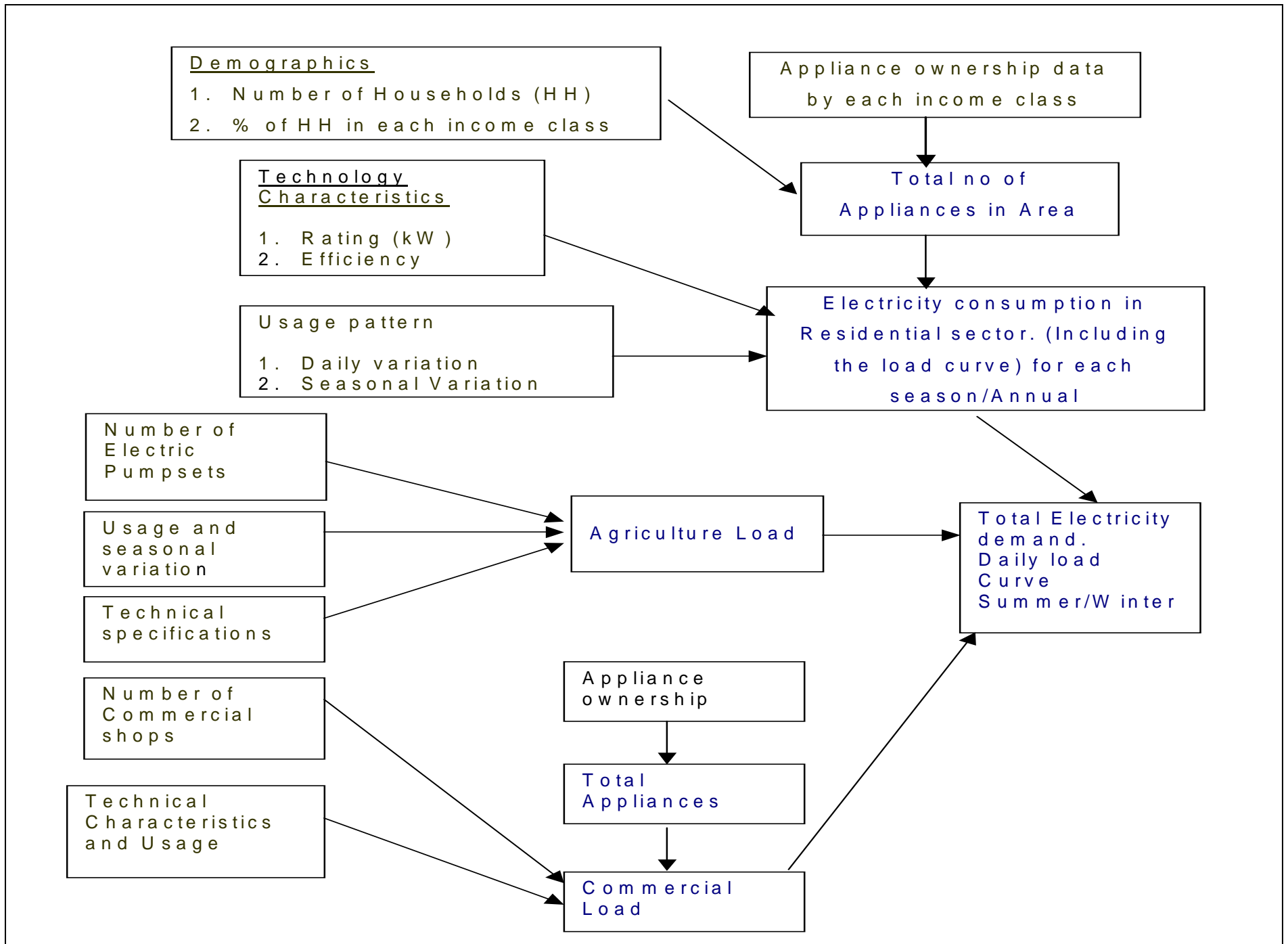

Village Electrification example

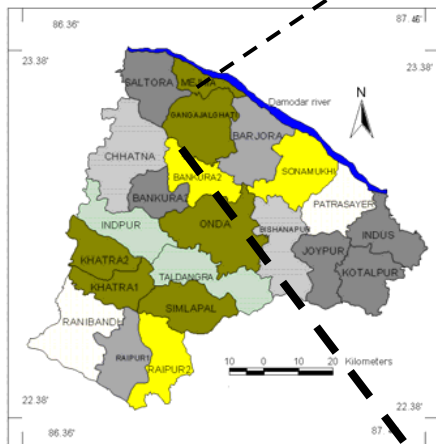

Administrative map of Bankura district, West Bengal.

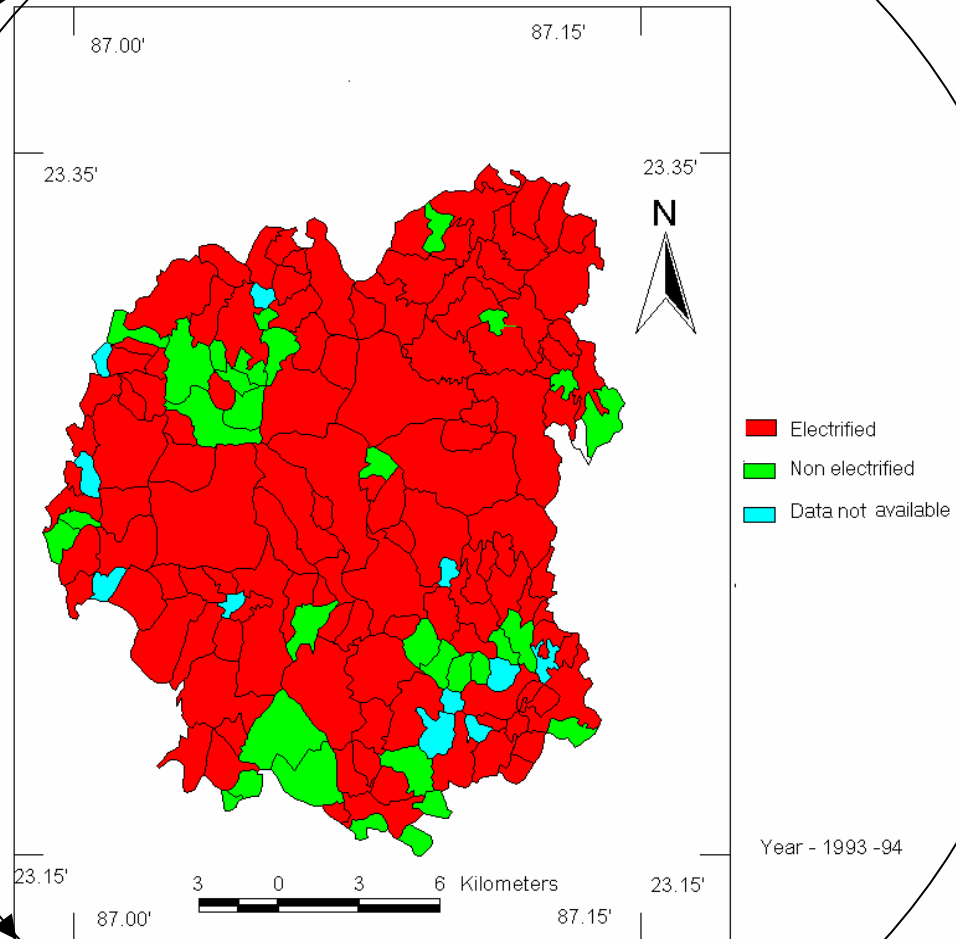

Year - 1993 -94

Source - Village level indicator

Map showing electrified and not electrified villages in Gangajalghati block

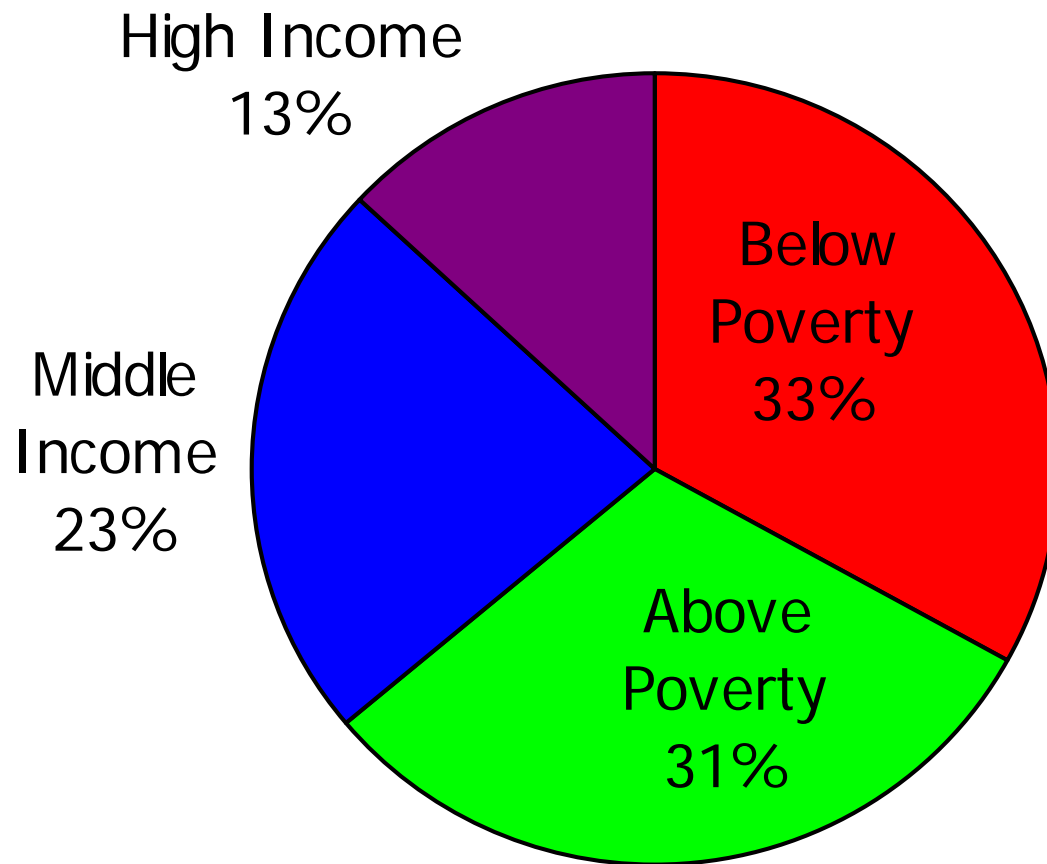

Income class distribution in Rajamele in 1994.

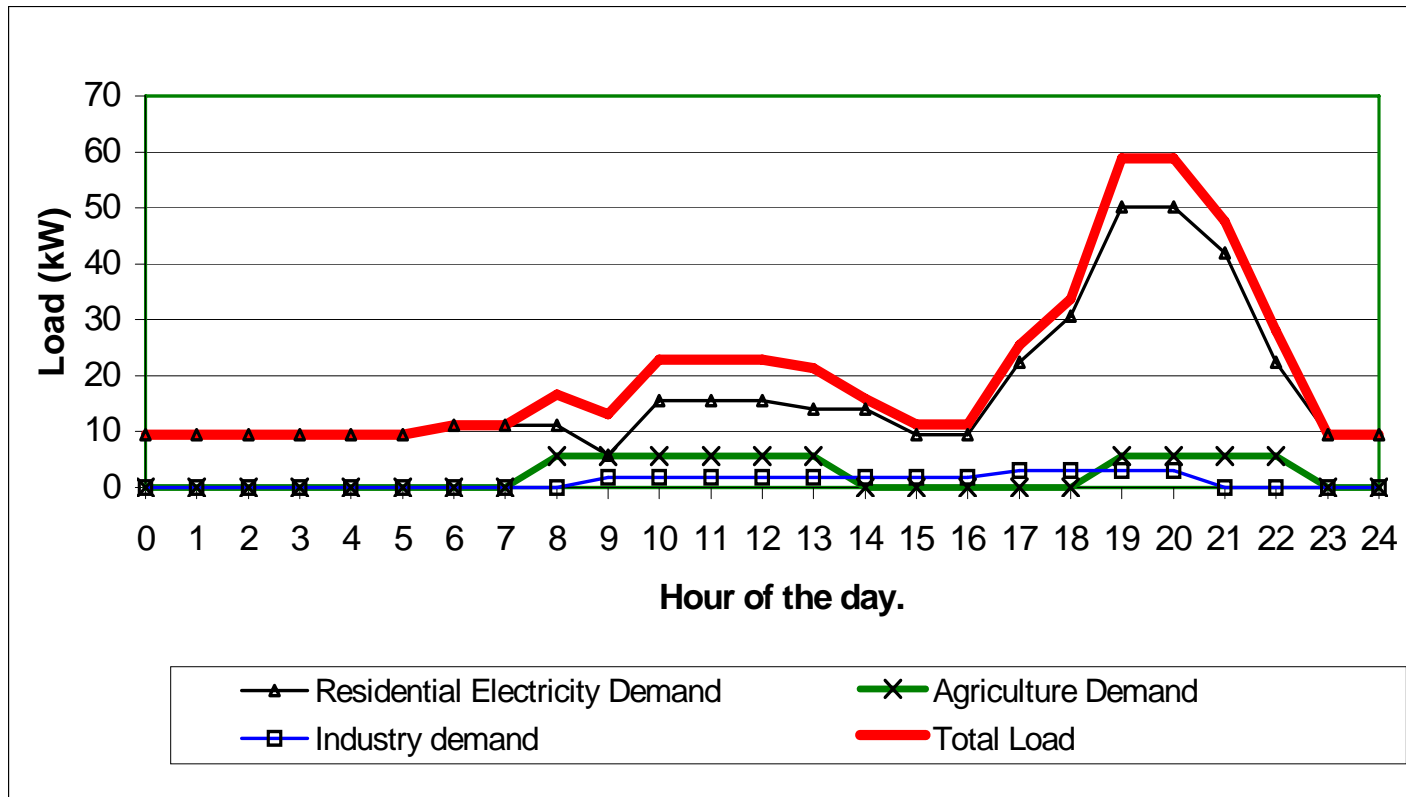

Daily load curve for Rajamele village in Summer in 2005



DSS Capability/Use

- Energy Quantification- from data already available/collected by Govt
- Assess impacts of development paths
- Quantify future commercial fuel demands – elec/coal/LPG/kerosene
- Rural Electrification- Load Profile Estimation, Sizing, Option Selection, Impact Assessment
- Spatial Representation of results
- Classification of areas as biomass surplus/deficit



Solar Water Heaters

- Estimate potential for solar water heaters in a given area
 - Develop generic framework
- 'Diffusion of Renewable Energy Technologies'



Factors Affecting Diffusion Of SWHS

- Location- Insolation
- Water Usage Pattern
- Cost of electricity
- Capital Cost
- Reliability
- Potential savings
- Subsidies/ Financial Incentives

Micro Level Decision Model (Parametric Analysis)

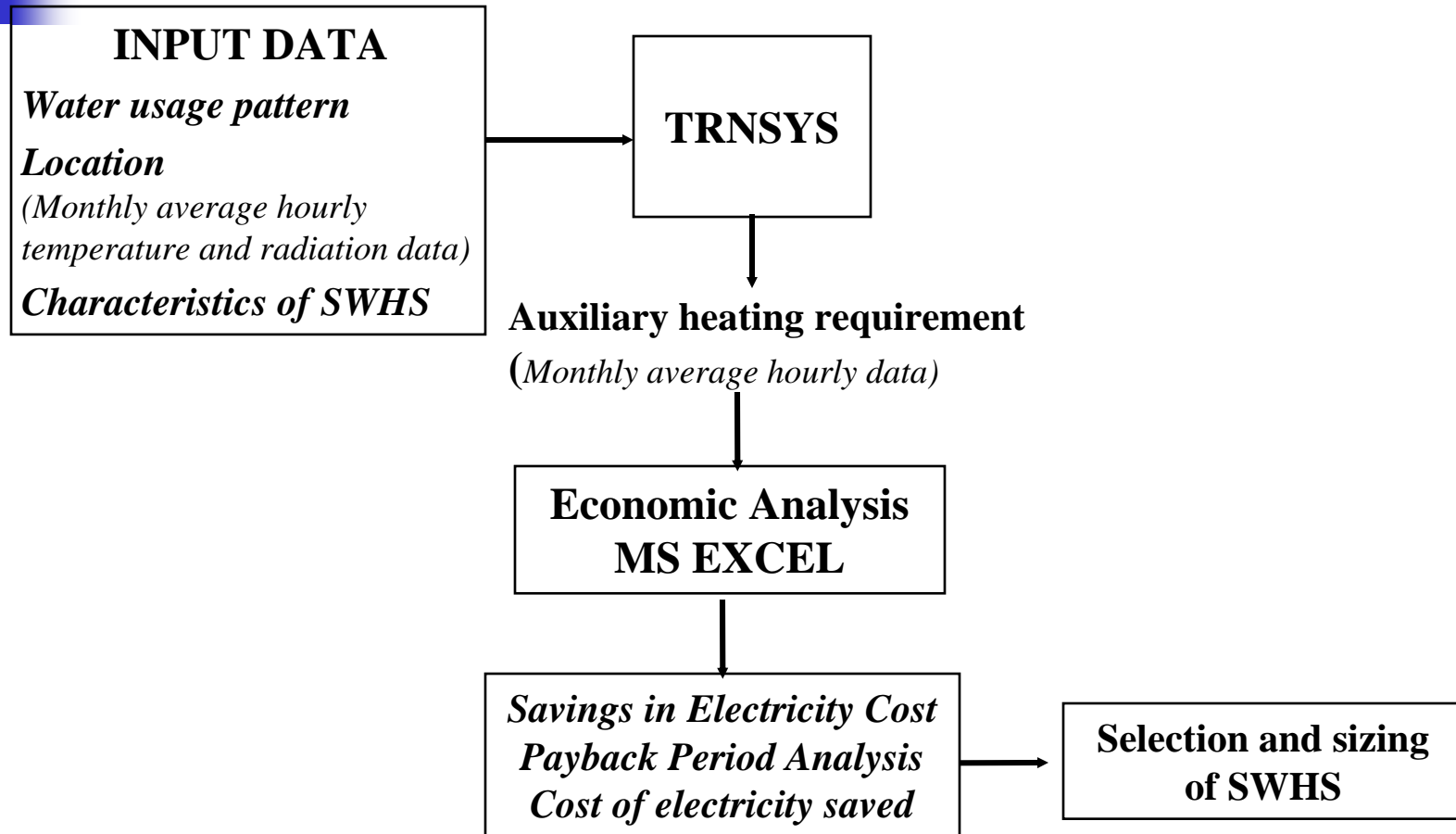

TRNSYS (Transient System Simulation Program developed at SEL, University of Wisconsin)

Information Flow Diagram of Micro – simulation for SWHS

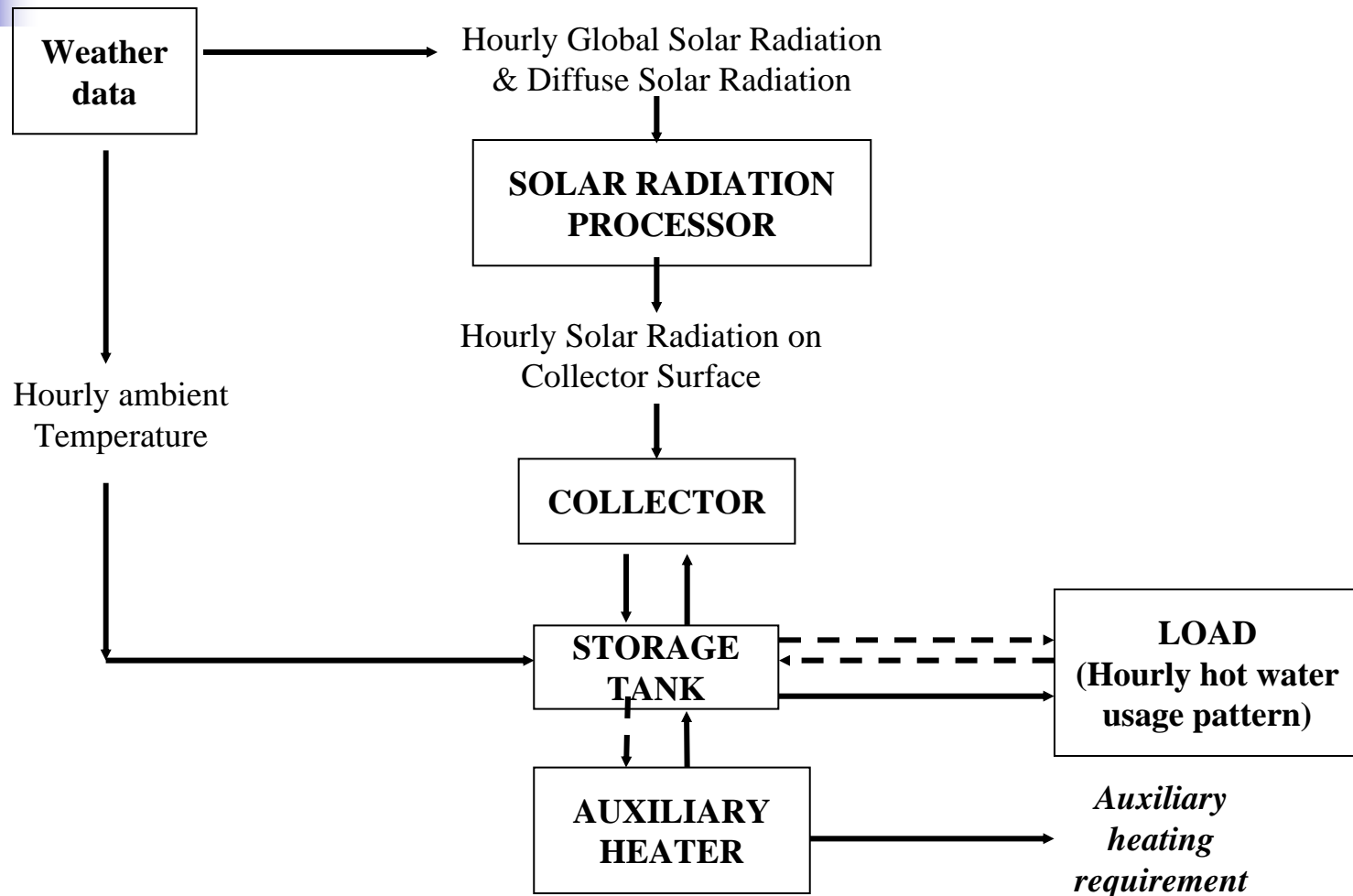

Model for Potential Estimation of Target Area

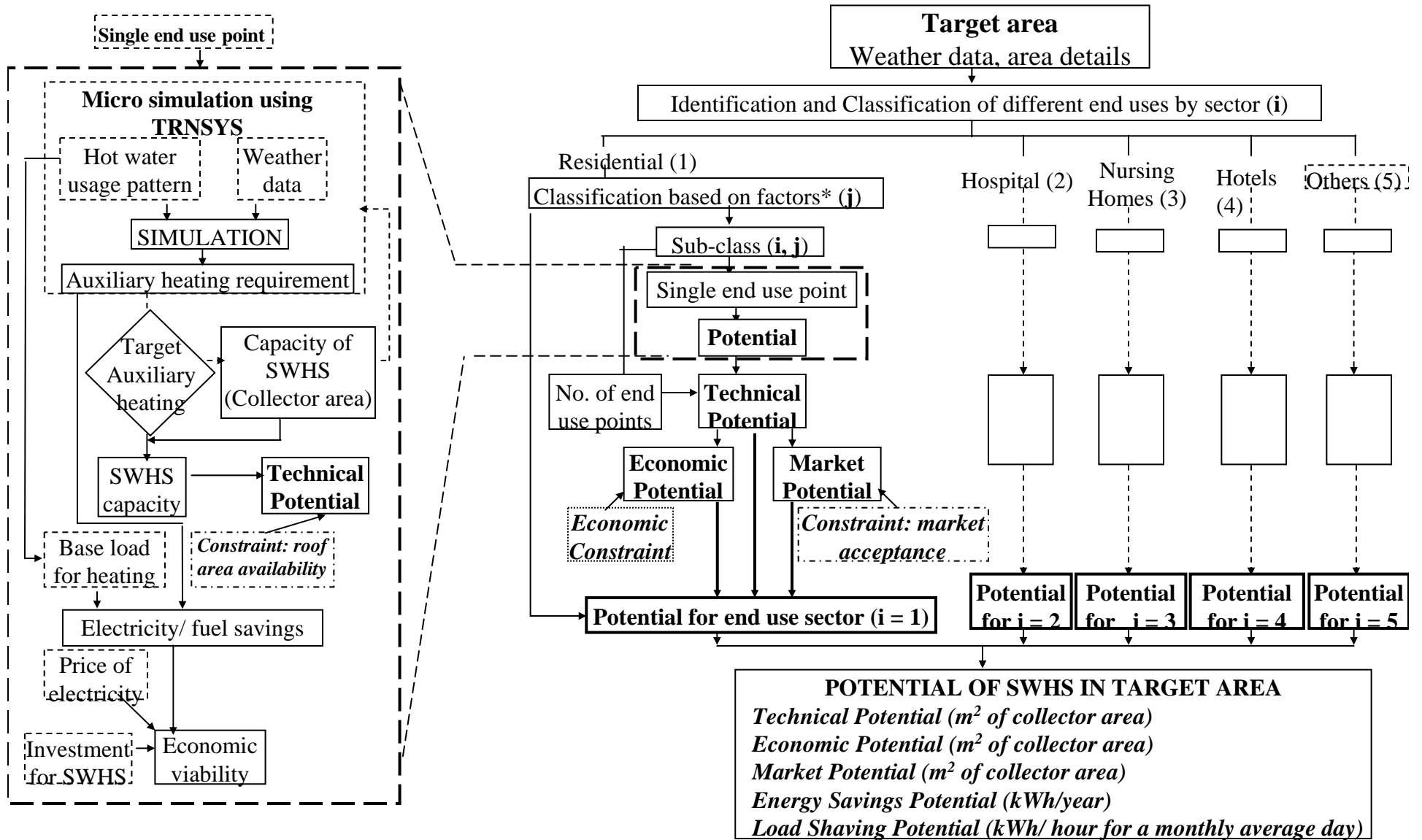

* Factors affecting the adoption/sizing of solar water heating systems



Potential Of SWHS

Technical potential P_{ij} for sub-class j in sector i is

$$P_{ij} = f_j f_{aj} N_i P_{sj}$$

where j denotes sub-class of end use points in sector i .

P_{sj} is the simulation output for a single end use point

f_j denotes fraction of the end uses

m is the total number of sub-classes.

f_{aj} is fraction of roof area availability

N_i is the number of end uses points in sector i

Technical Potential for sector i is

$$P_i = \sum_{j=1}^m P_{ij} \quad \text{where } i \text{ denotes sector}$$

Technical Potential of SWHS $P(T)$ in the target area is

$$P(T) = \sum P_i$$



Economic Potential

Economic potential of SWHS

$P(E)$: subset of technical potential

$$P(E)_{ij} = v_e P_{ij}$$

$v_e = 0$, if payback period $>$ maximum acceptable
limit

$v_e = 1$, if payback period $<$ maximum acceptable
limit

Payback Acceptance Schedule

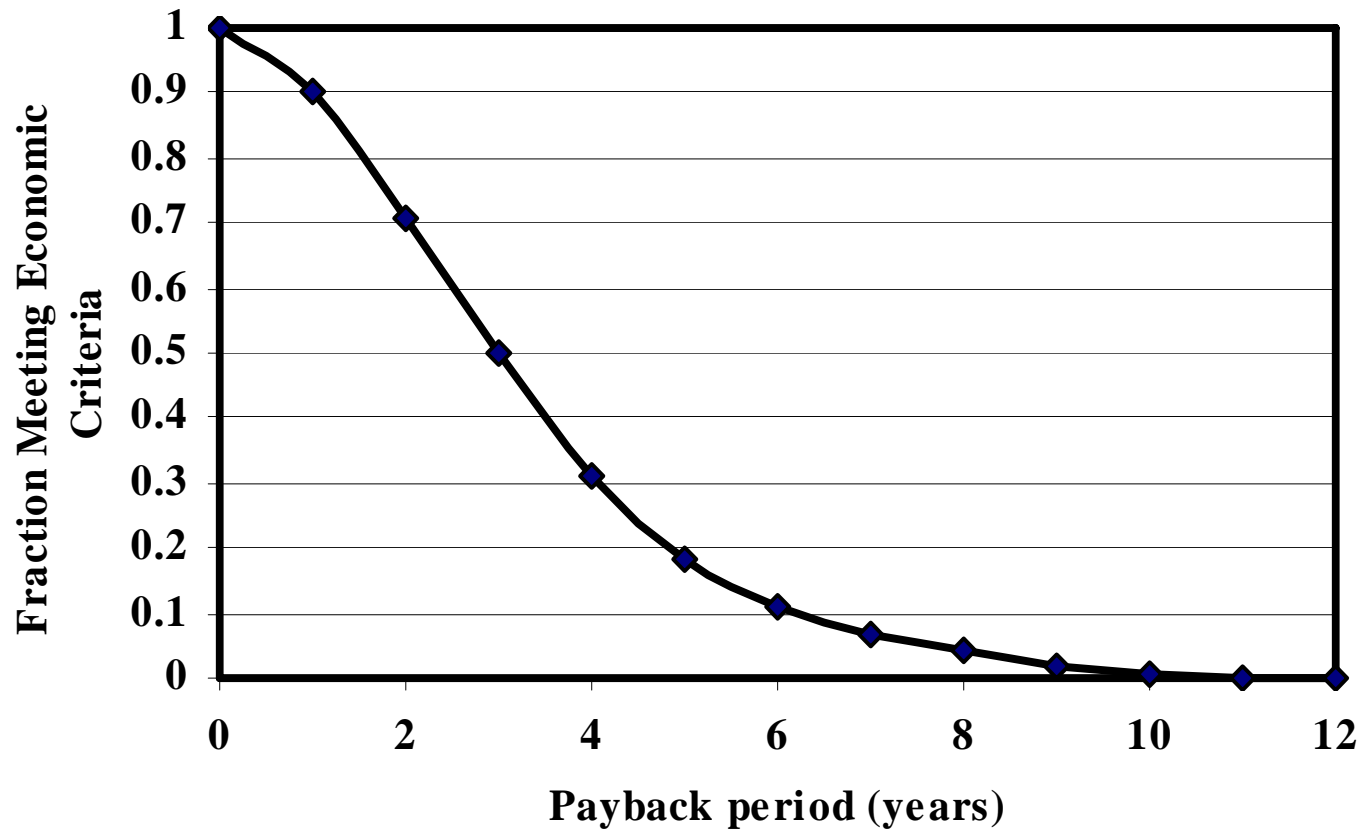

MARKET POTENTIAL

$$P(M)_{ij} = f_{pj} P_{ij}$$

$f_{p,j}$ is fraction of potential adopters meeting economic criteria.

Input Data For Potential Estimation Of SWHS in Pune

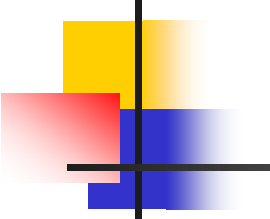

Target Area		Pune	
Area		138 sq.km	
Total Number of households		5.17 lakhs	
Number of households with more than three rooms		1.41 lakhs	
Average number of persons in each household		5	
Number of hospitals		394	
Capacity range of hospitals		1-570 beds	
Number of nursing homes		118	
Capacity range of nursing homes		1-50 beds	
Number of hotels		298	
Capacity range of hotels		10-414 inmates	
Number of households residing in single ownership houses		35250	
Number of buildings (4 flats in each floor)		6 floors	1400
		10 floors	880
		11 floors	840
Cost of electricity (Rs./kWh)	Residential	2.80	
	Commercial	4.00	

Hot Water Usage Patterns (Pune)

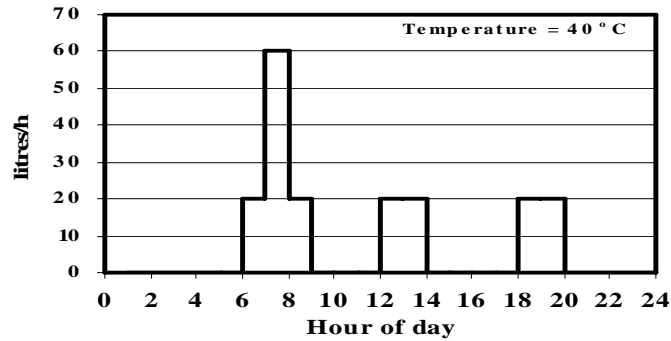

(a) Residential (1) [Gadgil, 1987]

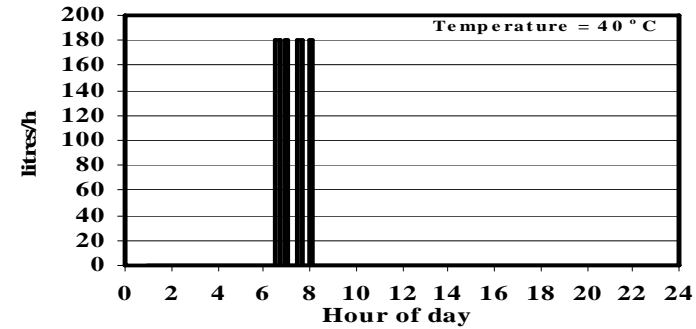

(b) Residential (2) [Narkhede, 2001]

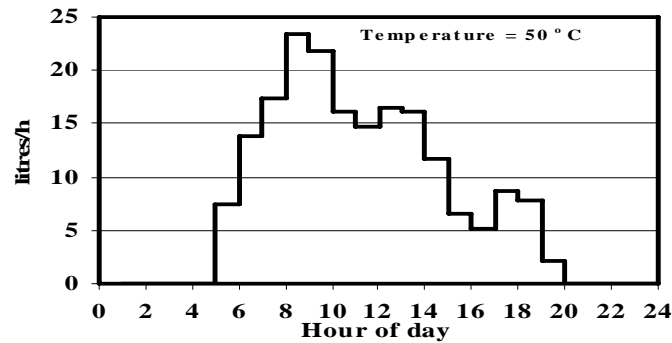

(c) Hospital (1 bed)

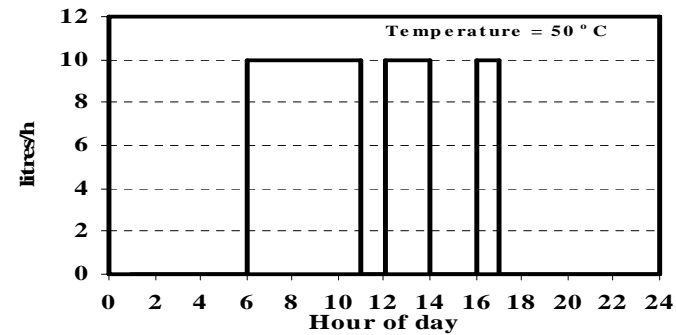

(d) Nursing Home (1 bed)

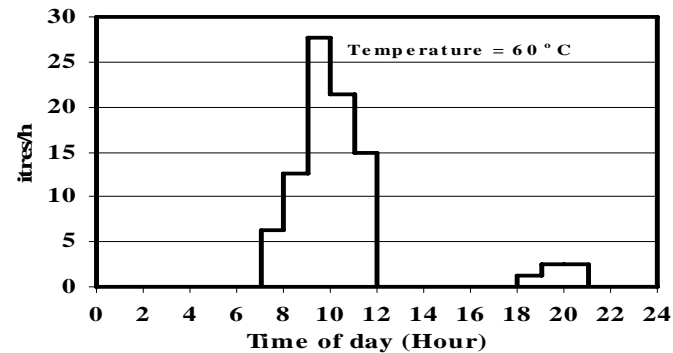

(e) Hotel - 1 guest

Monthly Average Ambient Conditions in Pune

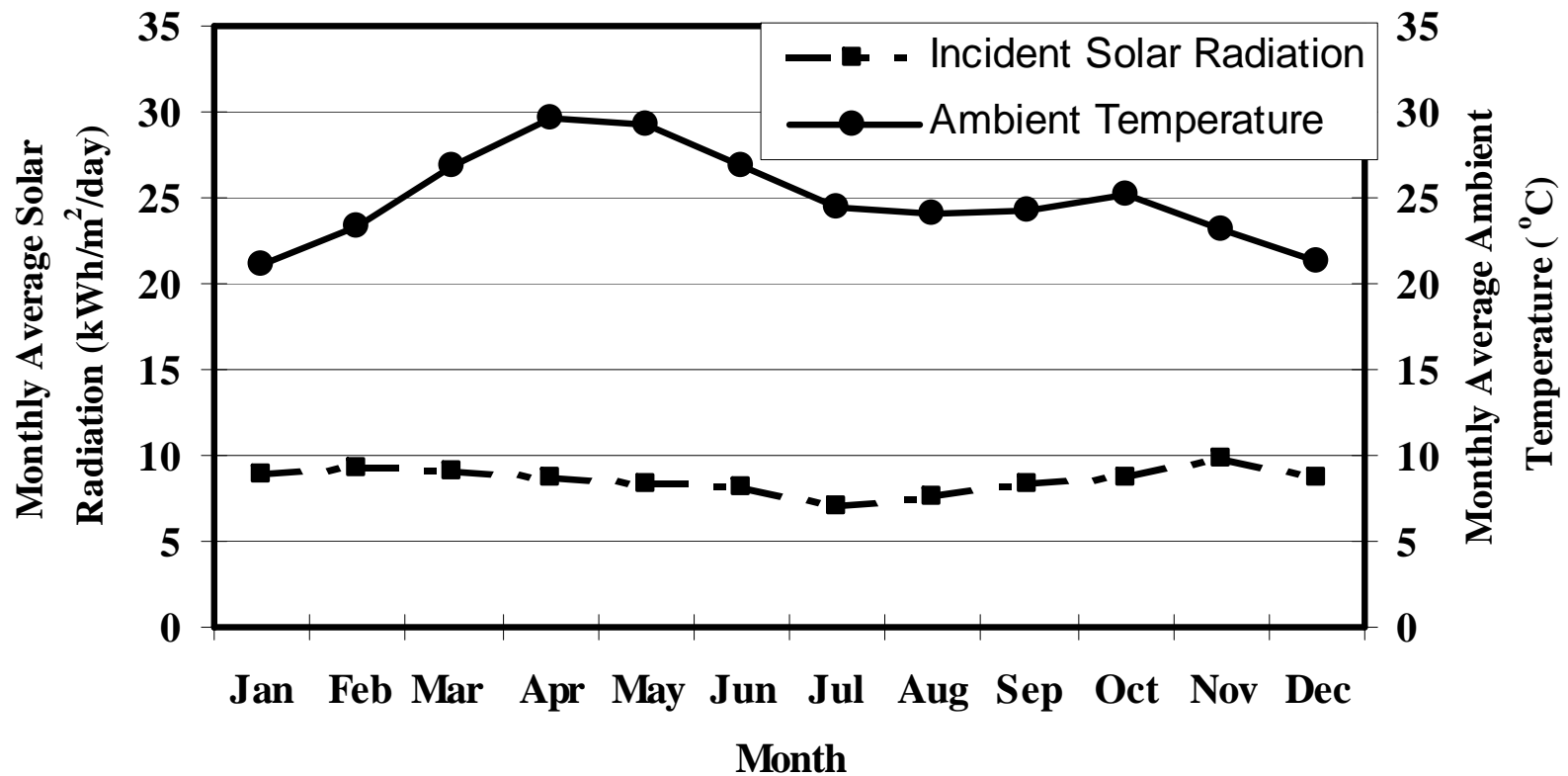

Mani, A. (1980) 'Handbook of solar radiation data for India'.

Sample simulation output and potential estimation for hospital with 5 beds

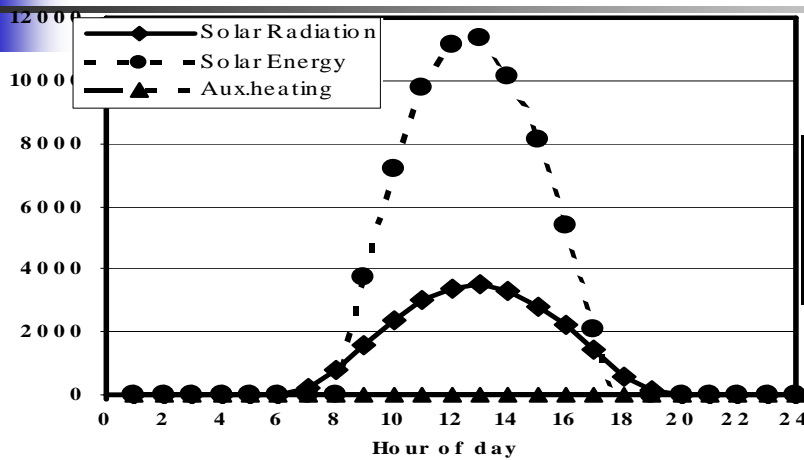

(a) Energy flow/ Solar Radiation for a typical day

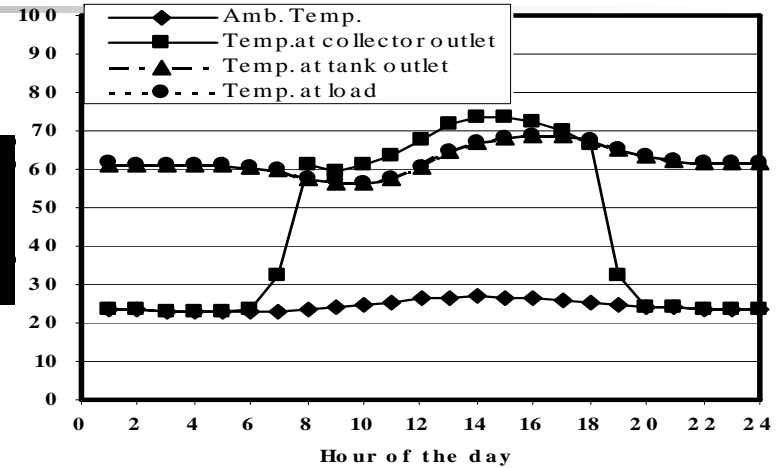

(b) Temperature profiles for a typical day

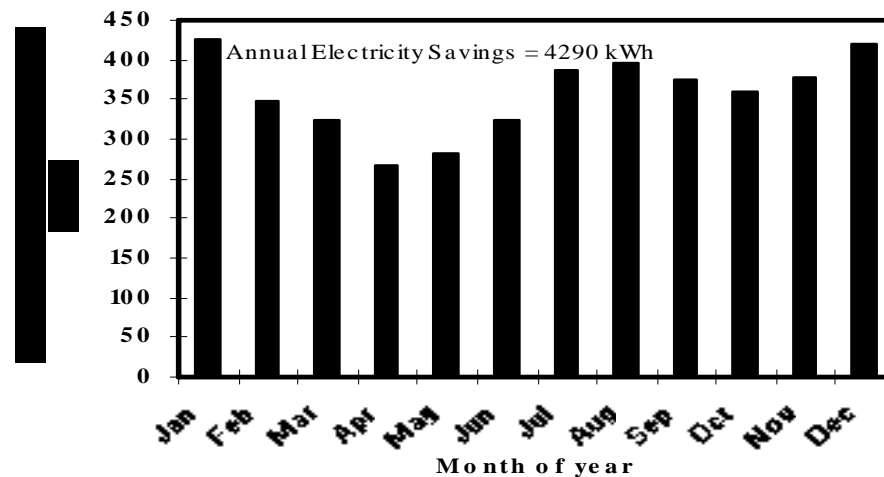

(c) Monthly variation in electricity savings

Potential Estimation of Sectors (Pune)

Sector		Technical Potential		Market Potential	
		Collector area (m ²)	Annual Electricity savings (kWh)	Collector area (m ²)	Annual Electricity savings (kWh)
Residential	Single houses	106000	37200000	2100	740000
	Multi-storeyed	227400	165000000	41000	29700000
Hospitals		5500	5900000	1700	1600000
Nursing homes		600	500000	300	280000
Hotels		13800	15900000	9300	10740000
TOTAL		353300	224500000	54400	43100000

Load Curve Representing Energy Requirement for Water Heating

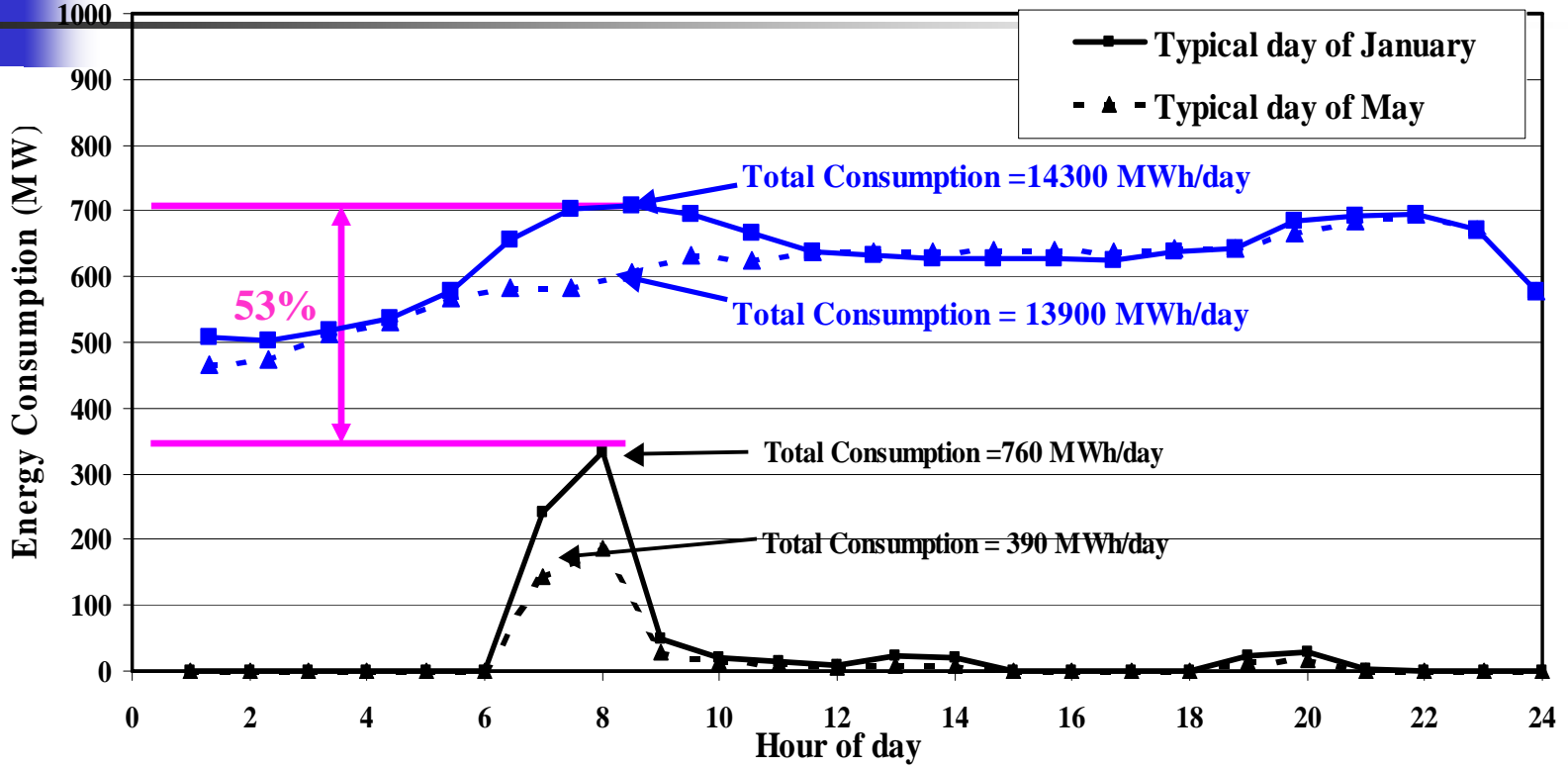

■ *Total Electricity Consumption of Pune*
■ *Electricity Consumption for water heating of Pune*

Achievable Potential Of SWHS For Different Payback Periods (Pune)

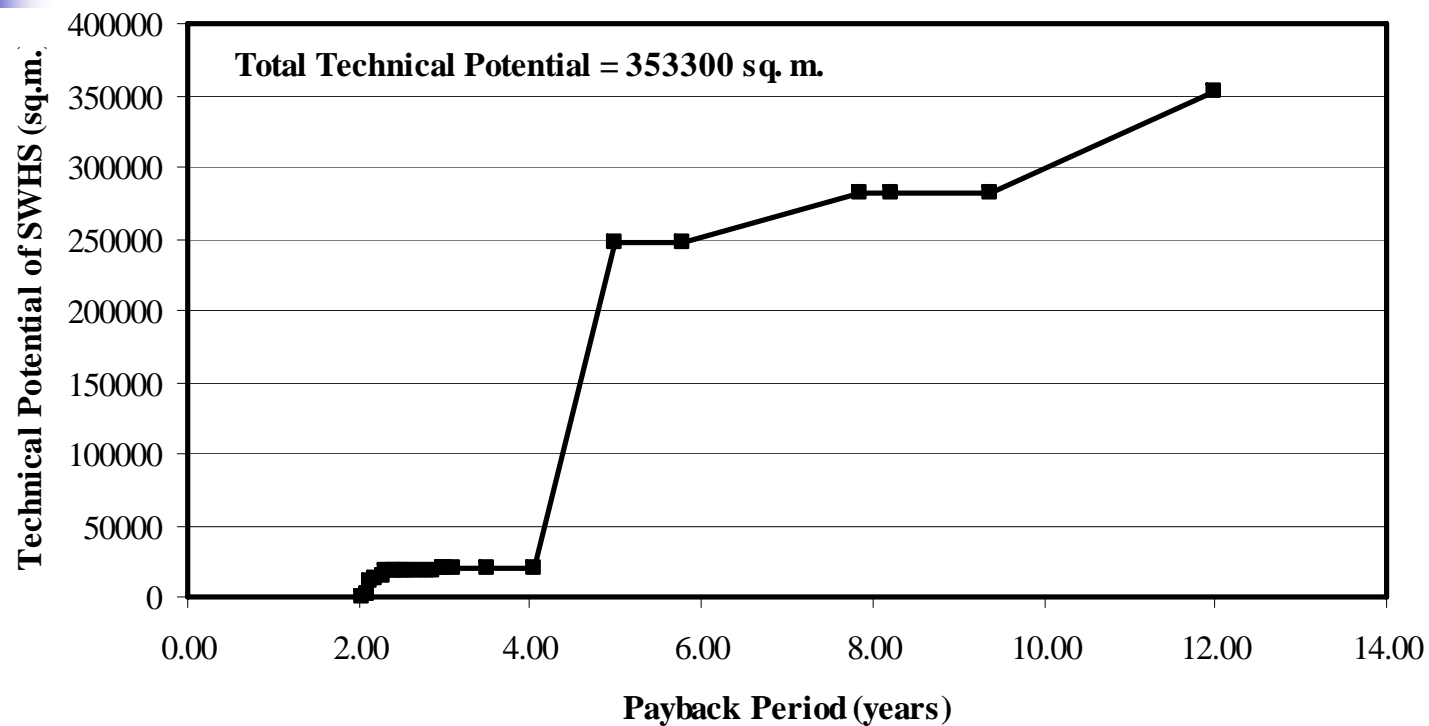

Economic potential (limit=payback period of 5 years) =19700 m² collector area

Framework for Potential Estimation of Solar Water Heating Systems in a Country

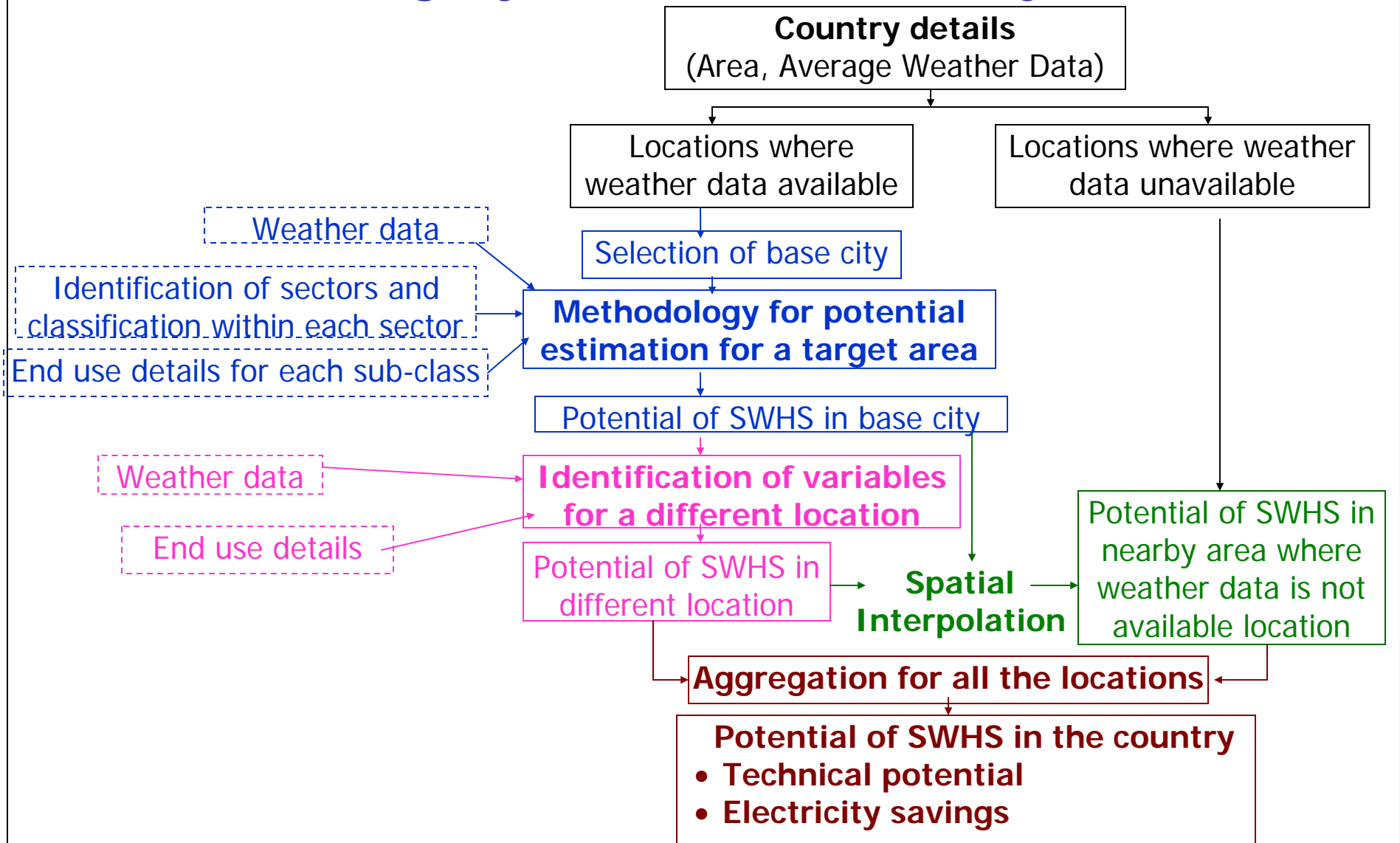

Diffusion of SWH

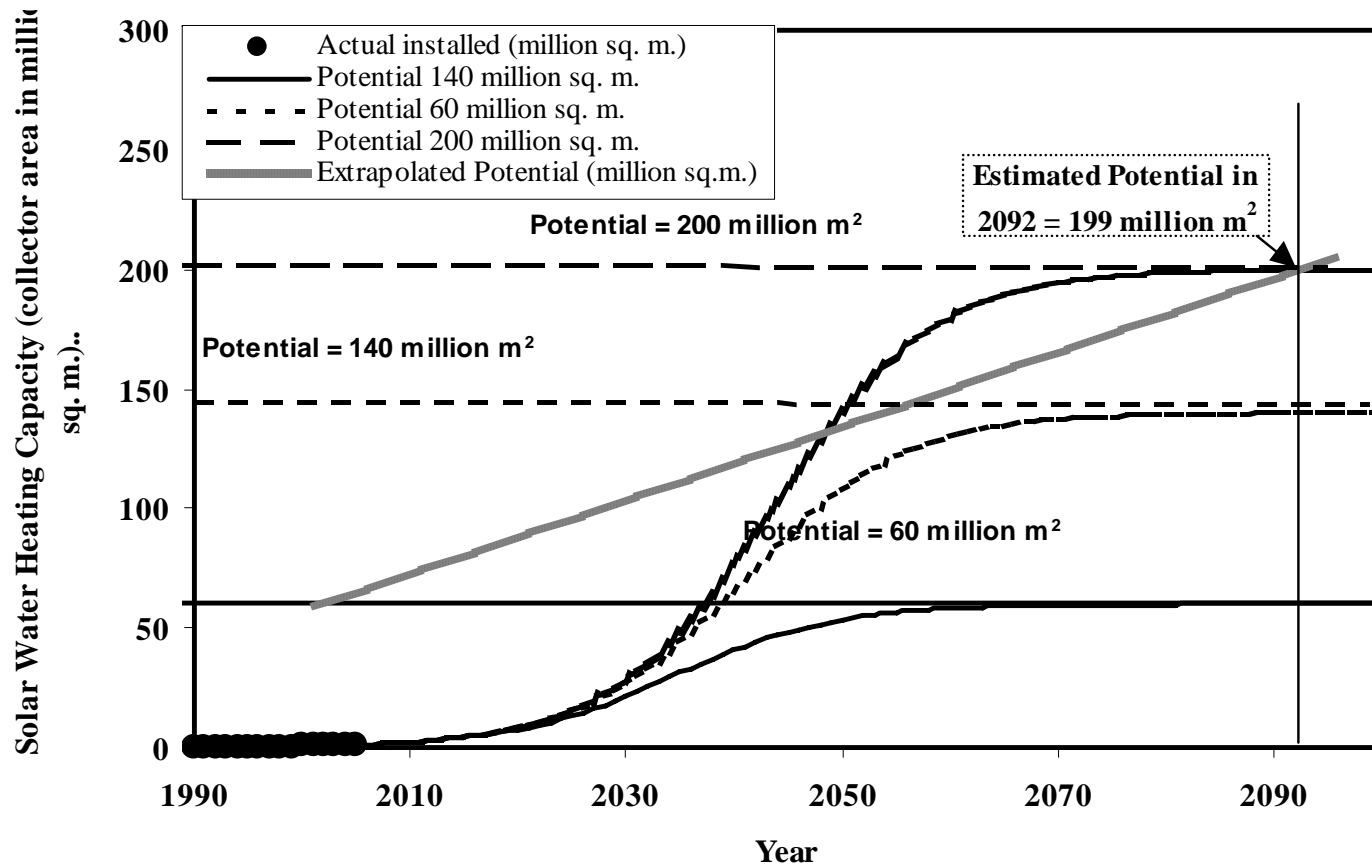



Summing Up

- Examples – illustrate variety of optimisation/ simulation models for energy sector
- Decision context and model formulation critical
- Generalisation important but..
- Data intensity and uncertainty

Acknowledgment



S. Ashok
Ph.D - 2003



Indu Pillai
Ph.D - 2008



Vishal S.
Ph.D. - 2008



U.N. Gaitonde
Faculty



Arun P.
Ph.D. - Ongoing



Santanu B.
Faculty

Sandeep Phulluke, Sagar Kasar,
Abhijit Bhure, Amit Khare, Jagdish
DSS Project Staff
(2004-2006)



Balkrishna Surve
Project Assistant

Thank you



References

- Ashok.S and R. Banerjee , “An Optimisation model for Industrial Load management”, IEEE Trans on Power Systems, Vol.16, No. 4, Nov.2001, pp 879-884.
- Ashok S and R. Banerjee , Optimal Operation of Industrial Cogeneration for Load Management, IEEE Trans on Power Systems, Vol. 18, No. 2, MAY 2003.
- Ashok.S and R.Banerjee, Optimal cool storage capacity for load management , Energy, Vol. 28, pp 115-126, 2003.
- Vishal S, U.N.Gaitonde,R Banerjee., “Model based energy benchmarking for glass furnace”, Energy Conversion and Management, Vol.48, pp 2718-2738, 2007.
- R. Banerjee, A. B. Inamdar, S. Phulluke, B. Pateriya, “Decision Support System for Energy Planning in a District”, Economic and Political Weekly, Vol. 34, No. 50, pp 3545-3552, 1999.
- R.Banerjee, Rahul Pandey, Abhijit Bhure and Sandeep Phulluke ,“Electricity Demand Estimation for Village Electrification ”, Proceedings of National Renewable Energy Conference , IIT Bombay, Nov. 30-Dec.2 ,2000.
- Rahul Pandey, R.Banerjee, Abhijit Bhure and Sandeep Phulluke ,“Framework for Design and Evaluation of Electric Supply Options for a rural area”, Proceedings of National Renewable Energy Conference , IIT Bombay, Nov. 30-Dec.2 ,2000.
- Arun P., Santanu Bandyopadhyay and R. Banerjee, ‘Sizing curve for design of isolated power systems’, Energy for Sustainable Development, Volume XI, No. 4, December 2007.
- Indu R. Pillai and R. Banerjee, ‘Methodology for estimation of potential for solar water heating in a target area’, Solar Energy, Vol.8, No.2, pp 162-17, 2007.