

# Energy Performance of Dump Trucks in Opencast Mine

*Lalit Kumar Sahoo, Santanu Bandyopadhyay and Rangan Banerjee*

*Department of Energy science and Engineering, Indian Institute of Technology Bombay, India*

**Abstract:** Dump trucks are used worldwide for handling ore and waste in most of the opencast mines. The energy consumption in dump trucks accounts for about 32 % of the total energy requirement in opencast mines. In this paper a modeling framework is developed to analyse a generic mine transportation problem with multiple dump trucks operating between multiple crushers and excavators. The minimum specific fuel consumption (SFC) of dump trucks for a specified pay load and material handling rate is optimized. The model investigates the variations of SFC with operating parameters like pay load, speed, wind speed etc. A case study of down gradient opencast limestone mine of capacity 2600 t/h shows a fuel savings of 15%. An achievable minimum SFC of 86 g/ton of ore handled is estimated using proposed model.

**Keywords:** Dump truck, opencast mine, energy performance, specific fuel consumption, optimization

## 1. Introduction

Mining processes are basically exploration, excavation, transportation and finishing of ore. Coal, metal and other minerals are excavated from the earth by opencast mining or underground mining. Mining industry consumes both electrical energy and diesel for processes like excavation, transportation and pumping. Dump trucks are used in excavator-truck based opencast mines for transferring ore or waste from the production site to either crushers or waste dump stations. The transportation network of the mine includes a fleet of dump trucks moving between crushers and excavators. The fleet size of dump trucks depends on the payload, material handling capacity of both excavators and crushers. Excavators are used to load the ore into the dump trucks and are movable depending upon the availability of ore. Crushers are stationary mechanical equipment used for sizing and finishing of ore.

Most opencast mines follow the same basic steps to produce the finished minerals. The schematic of opencast mining process is presented in Figure 1:

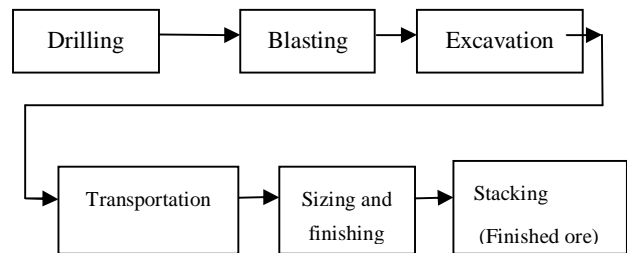

*Fig. 1. Schematic of opencast mining process*

Energy consumption in dump trucks accounts for 32% of total energy consumption in a typical Indian opencast coal mine [1]. The factors affecting specific fuel consumption of dump trucks are distance between crusher and excavator, payload, speed of vehicle and mine topography. The objective of this paper is to develop a mathematical model for calculating minimum energy consumption in dump trucks.

Statistical benchmarking has been used for industrial sectors to calculate minimum energy consumption. The evolution of energy star as an energy performance indicator (EPI) for benchmarking the industrial plant energy usage is discussed [2]. An energy benchmarking model [3] is developed for calculating minimum energy consumption for glass industries.

Corresponding Author: Lalit Kumar Sahoo, Email: lalitsahoo@yahoo.co.in

Studies for optimization of transportation have been based on linear programming approach. The optimization of loading and transport system in open cast mine has been done based on mathematical model [4] to optimize number of trucks required serving at loading point, number of trips per hour and theoretical output of dump trucks. Optimization of journey schedule of high capacity dump truck has been done to reduce the travel time of dump truck based on random variables with given expectation [5]. Constant speed profile minimizes the fuel consumption [6] in land transport vehicles. Fuel consumption increases as mass increases and is different for different combination of fuel and transmission type [7].

The literature reveals that there is no model that can be used to assess energy performance of dump truck operating in mines with variation of mine gradient, topography and payload. The objective of this paper is to develop a generic model for dump trucks operating in an opencast mine.

## 2.0. Problem statement

The objective is to develop a generic model for calculating minimum specific fuel consumption of dump trucks operating in opencast mine for different payload, gradient and varying mine topography.

### 2.1. Model development

The present model is developed for multiple dump trucks operating between multiple crushers and excavators for an opencast mine. When a vehicle moves, the engine has to deliver power against air, friction, rolling and gradient resistances. Theoretical power requirement for movement of both empty and loaded dump truck is calculated using mass balance and theory of vehicle dynamics. Fuel consumption per trip is calculated considering loading, unloading and travel time. Theoretical material handled is estimated from number of trips based on cycle time. Specific fuel consumption is calculated as the ratio of fuel consumption to the theoretical output

## 2.2. Governing equations of model

### 2.2.1. Mass balance of dump truck

The gross mass of dump truck ( $W_G$ ) is the sum of the weight of empty dump truck ( $W_E$ ) and the

payload ( $W_L$ ). The payload is defined as the material transferred by a dump truck in a single trip.

The mass balance of dump truck is given as

$$W_G = W_L + W_E, \quad (1)$$

Pay load depends on volumetric capacity of dump truck ( $S_L$ ) and the density of ore ( $\rho_{ore}$ ) to be transferred and is given as

$$W_L = S_L \rho_{ore}, \quad (2)$$

The pay load is restricted by the maximum capacity of truck as given in (3).

$$W_L \leq W_{L, \max} \quad (3)$$

### 2.2.2. Power requirement of dump truck

The equations for power requirement for empty truck moving from crusher to excavator ( $P_{ce}$ ) and loaded dump truck moving from excavator to crusher ( $P_{ec}$ ) are given in (4) and (5).

$$P_{ce} = V_{ce}(aV_{ce}^2 + bW_E), \quad (4)$$

$$P_{ec} = V_{ec}(aV_{ec}^2 + cW_G), \quad (5)$$

Where a, b and c are constants for drag resistance; rolling, friction and gradient resistances for down gradient mine and are given as (6) to (8)

$$a = \frac{1}{2} C_d \rho_{air} A_F, \quad (6)$$

$$b = g \cos \theta (f + C_{rr}) + g \sin \theta, \quad (7)$$

$$c = g \cos \theta (f + C_{rr}) - g \sin \theta, \quad (8)$$

$$V_{ce, ec} \leq V_{\max}, \quad (9)$$

$$P_{ce, ec} \leq P_{\max}, \quad (10)$$

The gradient resistance increases with an increase in gradient in case of up gradient mine and decreases in case of down gradient mine. ( $\pm$ ) sign is considered depending on mine topography. (+) sign is taken for all up gradient mines and (-) sign is considered for

all down gradient mine or hill mines for loaded dump trucks and vice versa for empty trucks.

### 2.2.3. Engine Characteristics

The engine power of internal combustion engine is the function of angular velocity as

$$P = \sum_{i=1}^3 P_i w_{e,i}^i, \quad (11)$$

Where,  $P_1, P_2, P_3$  for direct injection diesel engine are  $P_1 = 0.87 P_m/w_m$ ,  $P_2 = 1.13 P_m/w_m^2$  and  $P_3 = - P_m/w_m^3$

Power supplied by engine are presented as (12) and (13) by converting angular velocity to linear velocity using equation (14).

$$P_{ce} = a_1 V_{ce} + a_2 V_{ce}^2 - a_3 V_{ce}^3, \quad (12)$$

$$P_{ec} = a_1 V_{ec} + a_2 V_{ec}^2 - a_3 V_{ec}^3, \quad (13)$$

Where,

$$V_{ce, ec} = \frac{R_w W_e}{G_R} \quad (14)$$

And,  $a_1, a_2, a_3$  are constants .

Limiting speed for empty and loaded dump trucks  $V_{ce}$  and  $V_{ec}$  are obtained by equating (4, 5) and (12, 13) at the condition of maximum power that engine can deliver.

#### Brake specific fuel consumption

The brake specific fuel consumption ( $B_F$ ) is a function of speed of vehicle for empty and loaded truck and are presented as (15) and (16)

$$B_{F, ce} = b_1 V_{ce}^2 - b_2 V_{ce} + b_3, \quad (15)$$

$$B_{F, ec} = b_1 V_{ec}^2 - b_2 V_{ec} + b_3, \quad (16)$$

Where  $b_1, b_2, b_3$  are constants and are obtained from engine characteristic curve.

### 2.2.4. Fuel consumption per trip

Fuel consumption in dump truck moving between crusher and excavator s is given in (17), (18).

$$m_{f, ce} = P_{ce} B_{F, ce} \quad (17)$$

$$m_{f, ec} = P_{ec} B_{F, ec} \quad (18)$$

Now travel times from  $i^{\text{th}}$  crusher to  $j^{\text{th}}$  excavator and return journey are calculated using (19), (20).

$$t_{ij} = \frac{L_{ij}}{V_{ce}} \quad (i = 1, 2, \dots, M; j = 1, 2, 3, \dots, N), \quad (19)$$

$$t_{ji} = \frac{L_{ji}}{V_{ec}} \quad (i = 1, 2, \dots, M; j = 1, 2, 3, \dots, N), \quad (20)$$

The generalized equation for fuel consumption per trip of dump truck moving between  $i^{\text{th}}$  crusher and  $j^{\text{th}}$  excavator considering travel time , load and un load time , waiting or delay time is written as (21).

$$M_{f, ij} = m_{f, ce} t_{ij} + m_{f, ec} t_{ji} + m_{f, idle} (t_{load, UL} + t_{wait}), \quad (21)$$

$$\text{For optimization, } t_{wait} = 0 \quad (22)$$

### 2.2.5. Theoretical material handling output

Theoretical material handling output per hour of mine is calculated from cycle time and maximum pay load of dump truck.

#### Cycle time

Cycle time of dump truck is defined as the time required for complete cycle of dump truck movement from one excavator to one crusher or waste dumping station. Mathematically, the travel time and cycle time are given in (23), (24)

$$t_{travel} = t_{ce} + t_{ec}, \quad (23)$$

$$t_{d, cycle} = t_{load, UL} + t_{travel} + t_{wait}, \quad (24)$$

#### Trip Frequency

The trip frequency of dump truck directly affect the production output of opencast mine. The trip frequency should be maximized to achieve minimum fuel consumption per ton of ore handling. The trip frequency is calculated using (25)

$$x_{ce} = \frac{1}{t_{d, cycle}}, \quad (25)$$

#### Theoretical handling output dump truck

Now theoretical output per hour of single dump truck is calculated using (26)

$$q_d = W_L x_{ce}, \quad (26)$$

### 2.2.6. Specific fuel consumption

Specific fuel consumption of dump truck on hourly basis is calculated using (27)

$$SFC_{dumptruck} = \frac{M_{f, ij} x_{ce}}{q_d} \quad (27)$$

### 3. Optimization of specific fuel consumption

The objective is to minimize fuel consumption of dump trucks moving between multiple crushers and excavators. In solving optimisation problem speed of empty and loaded truck are taken as decision variables. The optimization problem is formulated to calculate minimum specific fuel consumption for specific material handling demand and payload as (28) to (34) including equation (1) to (27).

Minimize

$$SFC_{dump\ truck} = \frac{\sum_{i=1}^M \sum_{j=1}^N HX_{ij}M_{f,ij}}{\sum_{i=1}^M D_i} \quad (28)$$

Subject to

$$\sum_{j=1}^N X_{ij}W_LH \geq D_i (i=1,2,3...M) , \quad (29)$$

$$\sum_{j=1}^N X_{ij}W_L \leq Q_{c,i} (i=1,2,3...M) , \quad (30)$$

$$\sum_{j=1}^M X_{ij}W_L \leq Q_{e,j} (j=1,2,3...N) , \quad (31)$$

$$\sum_{j=1}^N n_{dj} = \sum_{i=1}^M n_{di} , \quad (32)$$

Where,

$$n_{dj} = \frac{t_{d, cycle, ij}}{t_{load}} \quad (j=1,2,3.....N) \quad (i=1,2,3...M) , \quad (33)$$

$$X_{ij} = n_{dj}X_{ij} \quad (34)$$

All variables are positive

### 4. Case study of downgrade opencast mine

A case study of downgrade opencast limestone mine of M/s Shree cement Ltd, Rajasthan, India is considered for optimization and simulation of model.

#### 4.1. Input Parameters of Model

Design data and operating parameters of dump trucks, crushers and excavators are taken as input data of model and shown as Table No. 1- 3[9].

Table 1: Design specification of engine of dump truck

Parameter	Specifications
Type	Water cooled, Turbocharged , 4 stroke
No. of cylinder	6
Bore x Stroke	159 x 159 mm
Cylinder displacement	19 Litres
Rated power	522 kW @2100 RPM
Idle speed	750 RPM
T max	2731 Nm @1500 RPM

Table 2: Rated Physical parameters of dump truck

Parameters	Designed	Actual
Net vehicle mass	41t	
Rated Pay load	45.5t	52t,65t
Gross Vehicle mass	86.5t	93t,106t
Wheel radius	0.812m	
Frontal area	15.408 m <sup>2</sup>	

Table 3: Mine Topography and Resources

Parameters	Mine operating condition
Mine topography	Downgrade mine
Distance between crusher and excavator	
Minimum distance	1km
Maximum distance	2 km
Gradient	1:14 (4°)
Material	Limestone
Ore density (Limestone)	1550 kg/m <sup>3</sup>
Total no. of dump trucks	21
Capacity of dump trucks	52t,65t
Total no. of excavators	5
Capacity of excavators	1200 ton/h
Total no. of crushers	2
Capacity of crushers	1400 ton/h

#### 4.2. Solution Procedure and simulation

Fig.A.1 shows the information flow diagram for energy performance model of dump truck. The model is solved using excel solver with minimising SFC as objective function by changing  $V_{ce}$  and  $V_{ec}$ . The optimum speed is found to be 7.62 m/s (28 km/h) and 7.04 m/s (25 km/h) for empty and loaded dump truck respectively.

##### 4.2.1. Parametric analysis

The model capability is investigated for down gradient mine by parametric analysis and shown in Table 4. Variations of SFC with input parameters are presented in Fig no. 2-5. The effect of mine gradient and wind speed on SFC is not significant.

Table 4: Parametric analysis of input parameters

Parameters	Designed	Actual
Pay load	65t	30-65 t
Material handling	360 t/h	150-400 t/h
Distance	1.5 km	1.45 -1.7km
Mine gradient	4°	1-15 °
Wind speed	0 m/s	0-8 m/s

#### 4.2.2. Single Dump truck application

The optimal SFC of dump truck is 81.5 g/ton as shown in Fig.2 for a payload of 65t and handling of 360 ton/h in a distance of 1.5km. The corresponding fuel consumption is 29.3 kg/hr. The minimum cycle time estimated is 10.8 minute. Increasing the material handling rate will result in further increase of SFC as shown in Fig.3 and material handling per truck is limited up to 400 ton/h. The minimum SFC for 52t and 65t payload dump trucks is 93.7 g /ton and 81.5 g /ton respectively.

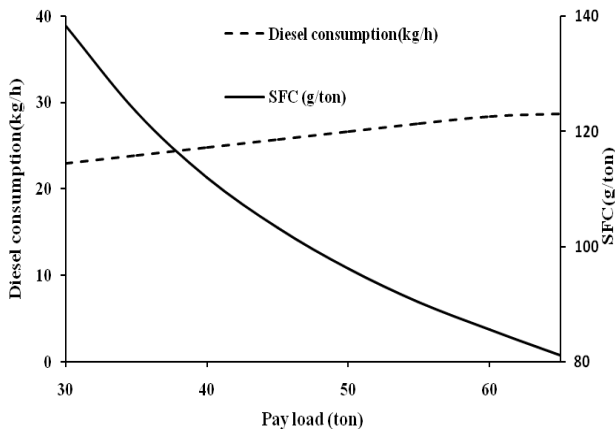

Fig. 2. Variation of diesel consumption and SFC for 65t payload

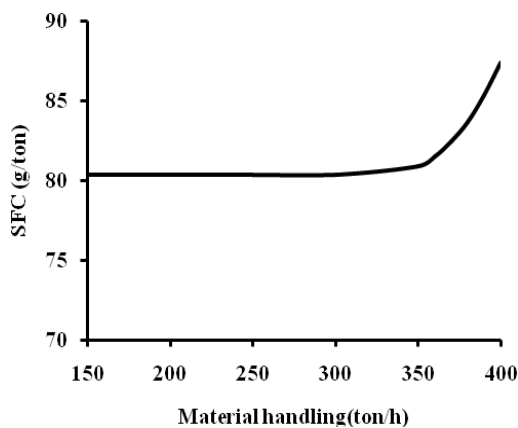

Fig. 3. Variation of SFC with handling due to increase in speed

#### 4.2.3. Multiple dump trucks

The optimal SFC variations with different material handling rate is shown in Fig.4 for single and multiple dump trucks. The maximum number of trucks allocation per excavator is 3 for a distance of 1.5km. The variation of SFC with distance shown in Fig.5 confirmed that the trend is linear for multiple excavator models located at different locations. The material handling of 1114 ton/h remains constant as an increase in distance decreases trip frequency and increases number of truck required to serve at loading point. The optimization problem as shown in (28) to (34) is solved by linear programming method. The solution of optimization problem yields SFC of 86 g/ton for ore handling of 2600 ton/h and pay load of 65t. The locations of excavators from crushers are 1.45km, 1.5km, 1.6 km, 1.65km and 1.7km.

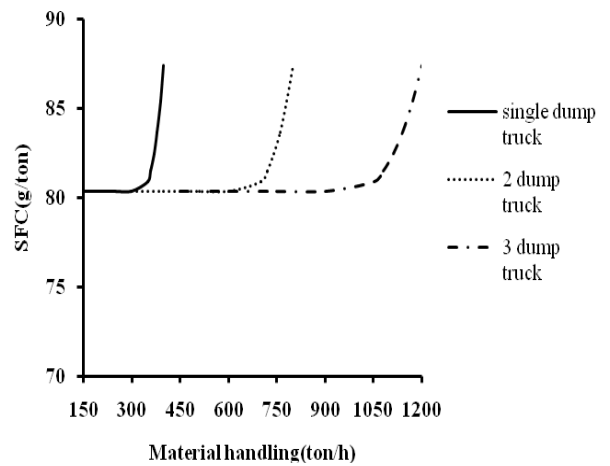

Fig. 4. Effect of multiple dump trucks on overall SFC

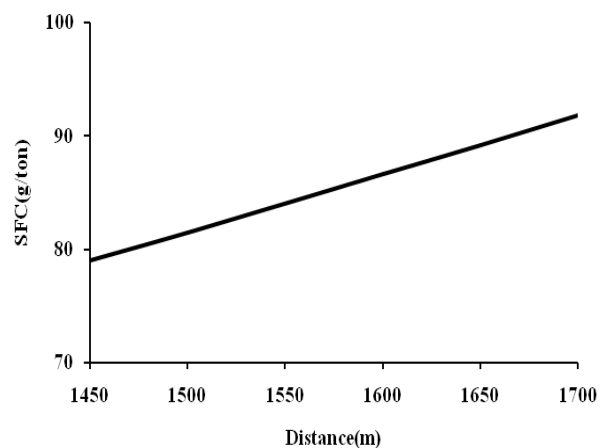

Fig. 5. Variation of SFC with distance for 65t dump truck

### 4.3. Experimentation and comparison of model result

Field studies have been conducted for experimentation for 1 hour at Nimbeti opencast mines of M/s Shree cements Ltd, Rajasthan, India and model results are compared with experimental results obtained from sample of 10 dump trucks. The full load diesel consumption was measured with calibrated dip-stick along with the corresponding number of trips to calculate the specific fuel consumption. There are two different capacities of dump trucks operating in the mine with same engine of 522 kW. The standard BH50M dump trucks of with Cummins engine has been converted to 52t and 65t capacity dump trucks by extending the body. The trend of diesel consumption shows that average hourly fuel consumption is 26.35 kg/h for material handling of 260 ton/h. The average SFC is 105 g/ton whereas minimum SFC using model is calculated to be 86 g/ton for pay load of 65t .The fuel saving potential estimated is 15 %.

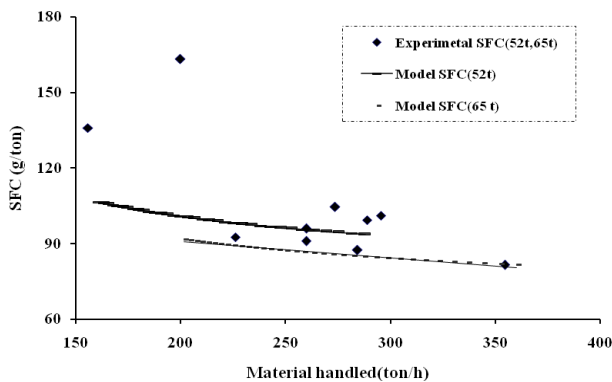

Fig. 6. Variation of SFC for 52t and 65t dump truck model and comparison with experimental data

### 4.4. Assumptions and limitations

#### 4.4.1. Assumptions taken in model

Model is based on steady flow of dump truck which moves at constant speed. Initial acceleration and final deceleration may change the fuel requirement. However as reported by Chang et al. [6] such changes are negligible and hence this aspect is neglected in this paper. Loading time is presently assumed as constant. Model is developed considering fixed locations of crushers and excavators. The distance between crusher and excavator is taken as mean of maximum and minimum distances for assessing energy performance of dump trucks based on the mine layout.

#### 4.4.2. Limitations of Model

Uncertainty of loading time that depends on ore hardness, density and digging geometry is not considered. Therefore it is difficult to assess the exact fuel consumption. Hence model can assess average energy performance of dump truck.

### 5. Results and discussions

The minimum specific fuel consumption calculated for a simple mine transportation system of 2 crushers and 3 excavators for Nimbeti opencast mine of Shree cement is 86 g/ton. The annual material handling demand is 10.4 million ton and the dump truck operating hour is 4000h. Experimental results of 52t and 65t dump truck operating in an opencast mine result in average SFC of 105 g/ton. The optimum path and number of trips/h are E1-C2 (18), E2-C1 (18), E3-C1 (2) and E3-C2 (2). E1, E2, E3 and C1, C2, C3 are specified excavators and crushers in the mine site respectively. The sensitivity analysis is done for the model and given in Table A.1.

### 6. Conclusion

An energy performance model for dump trucks in opencast mine has been developed. The model is used for predicting the minimum fuel consumption of mine transport with multiple dump trucks. The model is used for recommending speed required for empty and loaded truck, optimal allocation of number of trucks and optimum trip frequency. The optimal speed is 28 km/h for empty dump truck and 25 km/h for loaded dump truck.

The minimum SFC is 86g/ton for present case of down gradient mine and the fuel saving potential is 15%. The model can be extended for evaluating minimum SFC for different mine gradient and topology. The model can be applied for other end use opencast mines like coal, lignite, manganese, iron etc. The model can be used to assess energy performance of other truck transport system. The model is useful to predict the optimum number of dump truck required and expected fuel consumption of new opencast mine during mine planning.

### Nomenclature

- $A_F$  Frontal cross sectional area of dump truck,  $m^2$
- $B_F$  Brake specific fuel consumption,  $gm/kWh$

$C_d$	Drag coefficient
$C_{rr}$	Coefficient of rolling resistance
$D$	Annual demand of material handling/crusher, tons
$f$	Coefficient of friction between tyre and soil
$g$	Acceleration due to gravity, $m/s^2$
$G_R$	Gear ratio of dump truck
$H$	Annual operating hours of dump truck
$L$	Distance between crusher and excavator, m
$m_f$	Mass of fuel consumption during dump truck movement, kg/h
$m_{f, idle}$	Mass of fuel consumption during engine idling of dump truck, kg/h
$M_f$	Mass of fuel consumption in one trip, kg
$n$	Number of dump trucks
$P$	Power required by dump truck, kW
$q_d$	Theoretical material output, ton/h
$Q$	Maximum Capacity of crusher or excavator
$R_w$	Wheel radius of dump truck, m
$SFC$	Specific fuel consumption, kg/ton
$S_L$	Volume of dump truck, $m^3$
$t$	Time taken, h
$t_{load, UL}$	Loading and unloading time, h
$t_{wait}$	Waiting time, h
$t_{load}$	Loading time of dump truck, h
$t_{travel}$	Travel time during empty and loaded cycle, h
$t_{d, cycle}$	Cycle time of dump truck, h
$V$	Average speed of dump truck, m/s
$W_E$	Weight of empty dump truck, ton
$W_L$	Rated Pay load, ton
$W_G$	Gross vehicle mass, ton
$w_e$	Angular velocity of engine, rad/s
$w_m$	Rated angular velocity of engine, rad/s
$x$	Trip frequency of dump truck, $h^{-1}$
$X$	Total number of trips per hour, $h^{-1}$

### Greek symbols

$\rho_{air}$	Density of air, $kg/m^3$
$\rho_{ore}$	Density of ore, $kg/m^3$
$\theta$	Mine gradient, radian

### Subscript and superscript

$c, e, m$  crusher, excavator, maximum  
 $i, j$  demand, supply

### References

- [1] Central Institute of Mining & Fuel Research (CIMFR), 1998, Energy Audit report of Umrer open cast mine, WCL, Nagpur, 201207
- [2] Boyd G., Dutrow E. and Tunnessen W., 2008, 'The evolution of energy star energy performance Indicator for benchmarking industrial plant energy use', Journal of cleaner production, 16, 709-715
- [3] Sardeshpande V., Gaitonde U.N. and Banerjee R., 2008, Model based energy benchmarking for glass furnace, Energy conver. Mgmt., 48, 2718-2378
- [4] Vemba M.M.D.S, 2004, The loading and transport system at SMC-Optimization, The Journal of South African Institute of Mining and Metallurgy, 139-147
- [5] Vasil'ev M. V, Smirnov V. P., 1974, Optimization of the journey schedules of high capacity Quarry dump trucks, The Institute of mining, Ministry of Ferrous metallurgy of USSR, Sverdlovsk., translated from Fiziko-Tekhnicheskii Problemy Razrabotki Poleznykh Isokopaemykh, No.1, 63-69
- [6] Chang D.J, Morlok E.K., 2005, Vehicle speed profiles to minimize work and fuel consumption, The Journal transportation engineering, 173-182
- [7] Tolouei.R., Titcheridge H., 2009, Vehicle mass as a determinant of fuel consumption and secondary safety performance, Transport research Part D
- [8] Jajar R.N., 2009, Vehicle Dynamics: Theory and application, Springer, USA
- [9] M/s Shree cement Ltd, 2009, Data received by correspondence based on CIMFR study on energy efficiency in opencast mine.

### Acknowledgements:

The first author is grateful to Mr. S.C.Suthar of Shree cement Ltd, Dr A.Sinha, Mr A.K.Chowdhury, Mrs Seema Topno of CIMFR and Cummins (India) Ltd for their help.

# Appendix

Table A.1: Sensitivity Analysis of Model

Input parameter	Base value (ton)	% change	Change over base value(ton) (Upper)	Change over base value(ton) (lower)	SFC ,base (g/ton)	SFC,change over(g/ton) base value (upper)	SFC,change over base value(lower) (g/ton)	Sensitivity Index (upper)	Sensitivity Index (lower)
Pay load	65	5%	68.25	61.75	81.5	79.2	84.1	-0.572	-0.630
$V_{ce}$	7.62	5%	8.001	7.239	81.5	83.2	80.0	0.410	0.375
$V_{ec}$	7.04	5%	7.39	6.68	81.5	82.1	81.2	0.141	0.079
Mine gradient	4	25%	5	3	81.5	81.3	81.7	-0.011	-0.008

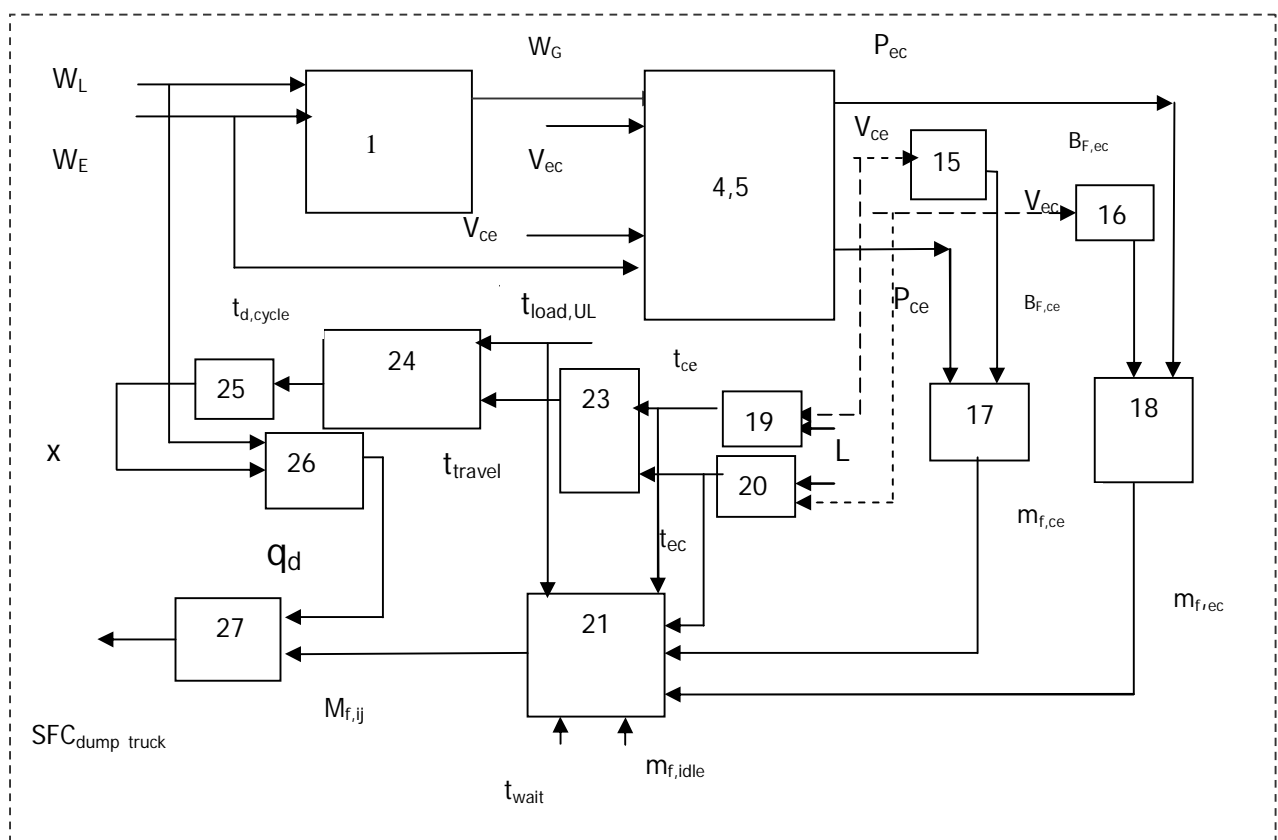

Note : Block numbers in Information flow diagram refers to equations in paragraph 2.2

Fig A.1. Information flow diagram for energy performance assessment model of dump truck