

# Grinding and Finishing

Illegitimi non carborundum

ver. 1



ME 338: Manufacturing Processes II  
Instructor: Ramesh Singh; Notes: Profs.  
Singh/Melkote/Colton

# Overview

- Processes
- Analysis



ME 338: Manufacturing Processes II  
Instructor: Ramesh Singh; Notes: Profs.  
Singh/Melkote/Colton



ME 338: Manufacturing Processes II  
Instructor: Ramesh Singh; Notes: Profs.  
Singh/Melkote/Colton



# Horizontal Grinding

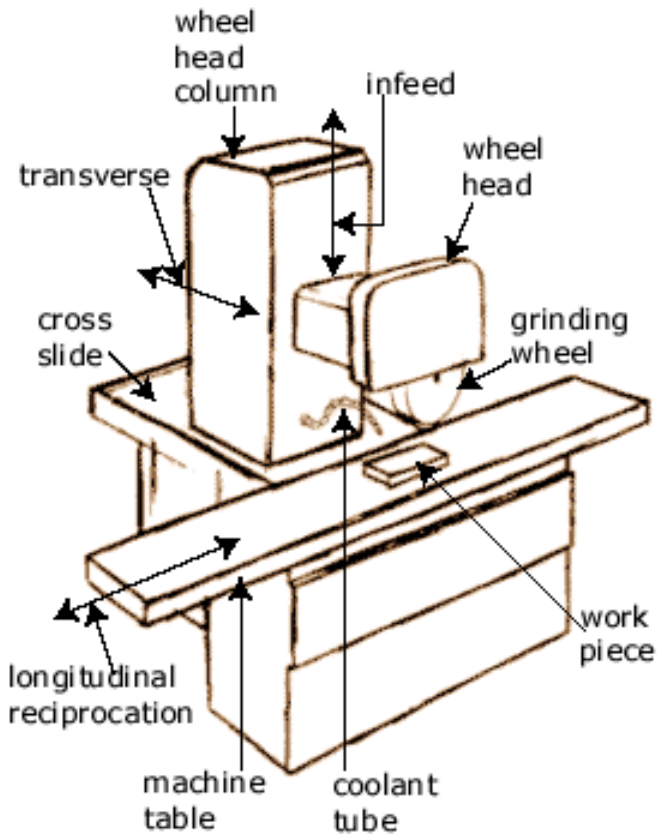



Instructor: Ramesh Singh; Notes: Profs.  
Singh/Melkote/Colton



# Horizontal grinding

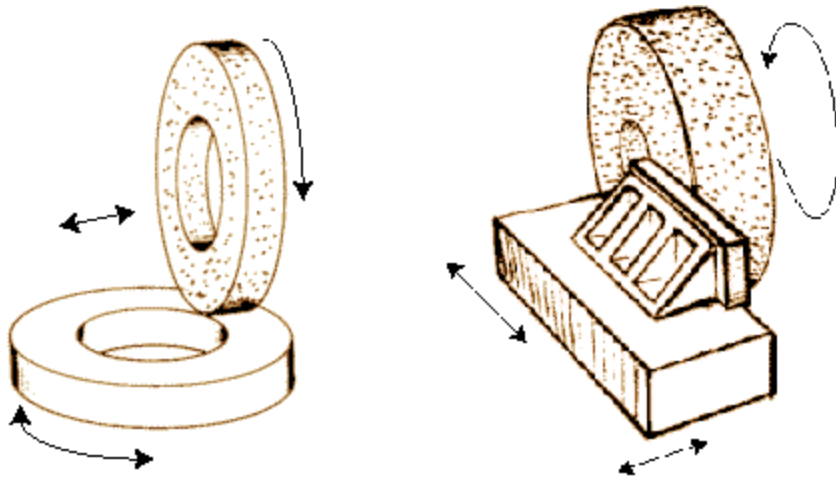
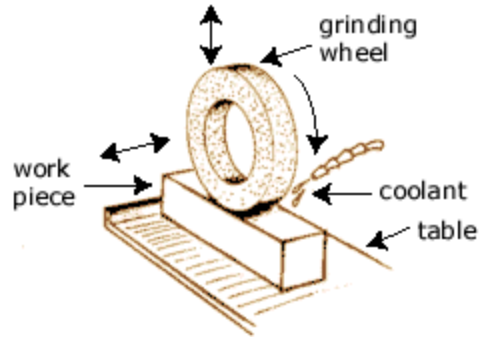

# Vertical grinding

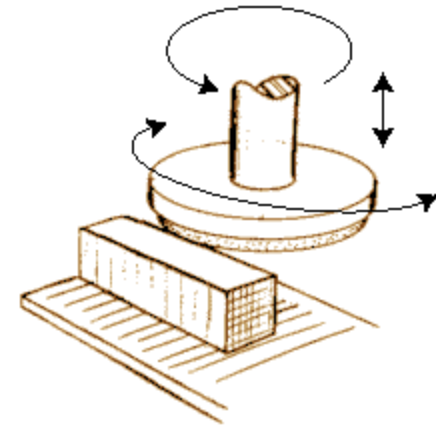
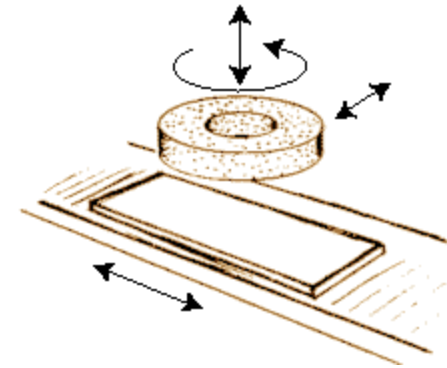

# Centered grinding

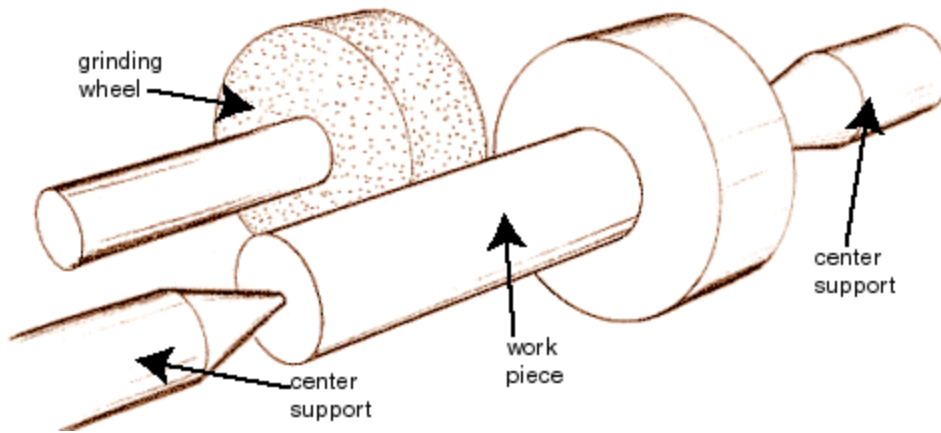

# Centerless grinding

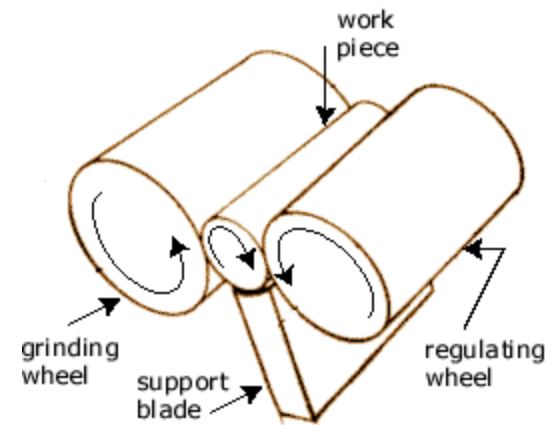

# Creep Feed Grinding

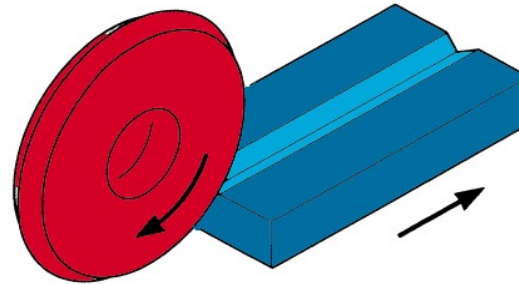
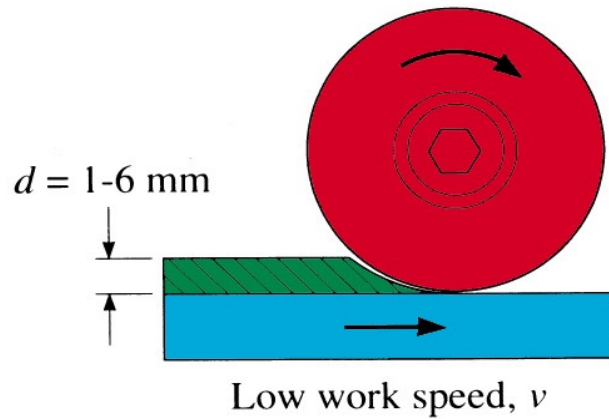

- Full depth and stock is removed with one or two passes at low work speed
- Very high forces are generated
- High rigidity and power

## Advantages

- Increased accuracy
- Efficiency
- Improved surface finish
- Burr reduction
- Reduced stress and fatigue

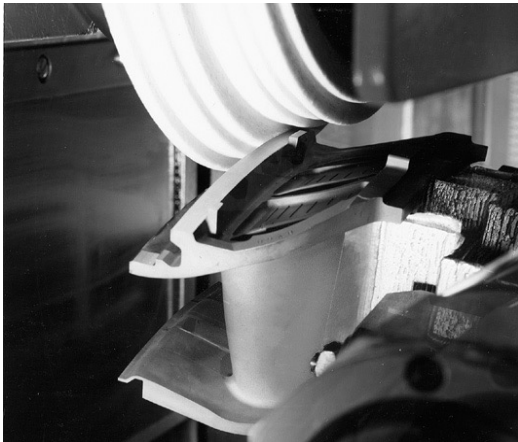



ME 338: Manufacturing Processes II  
Instructor: Ramesh Singh; Notes: Profs.  
Singh/Melkote/Colton



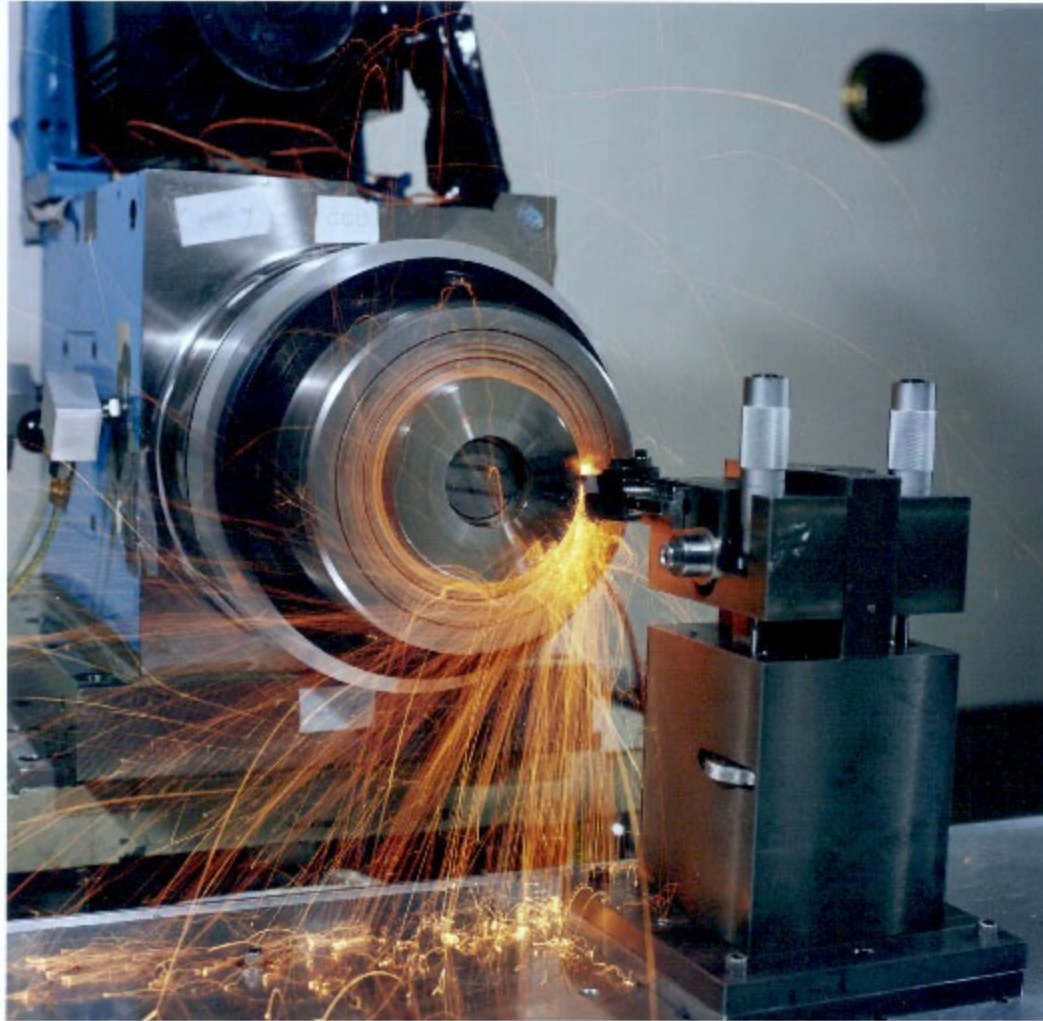

ME 338: Manufacturing Processes II  
Instructor: Ramesh Singh; Notes: Profs.  
Singh/Melkote/Colton





ME 338: Manufacturing Processes II  
Instructor: Ramesh Singh; Notes: Profs.  
Singh/Melkote/Colton





ME 338: Manufacturing Processes II  
Instructor: Ramesh Singh; Notes: Profs.  
Singh/Melkote/Colton

# Grinding Wheels



ME 338: Manufacturing Processes II  
Instructor: Ramesh Singh; Notes: Profs.  
Singh/Melkote/Colton



# Grinding Wheels

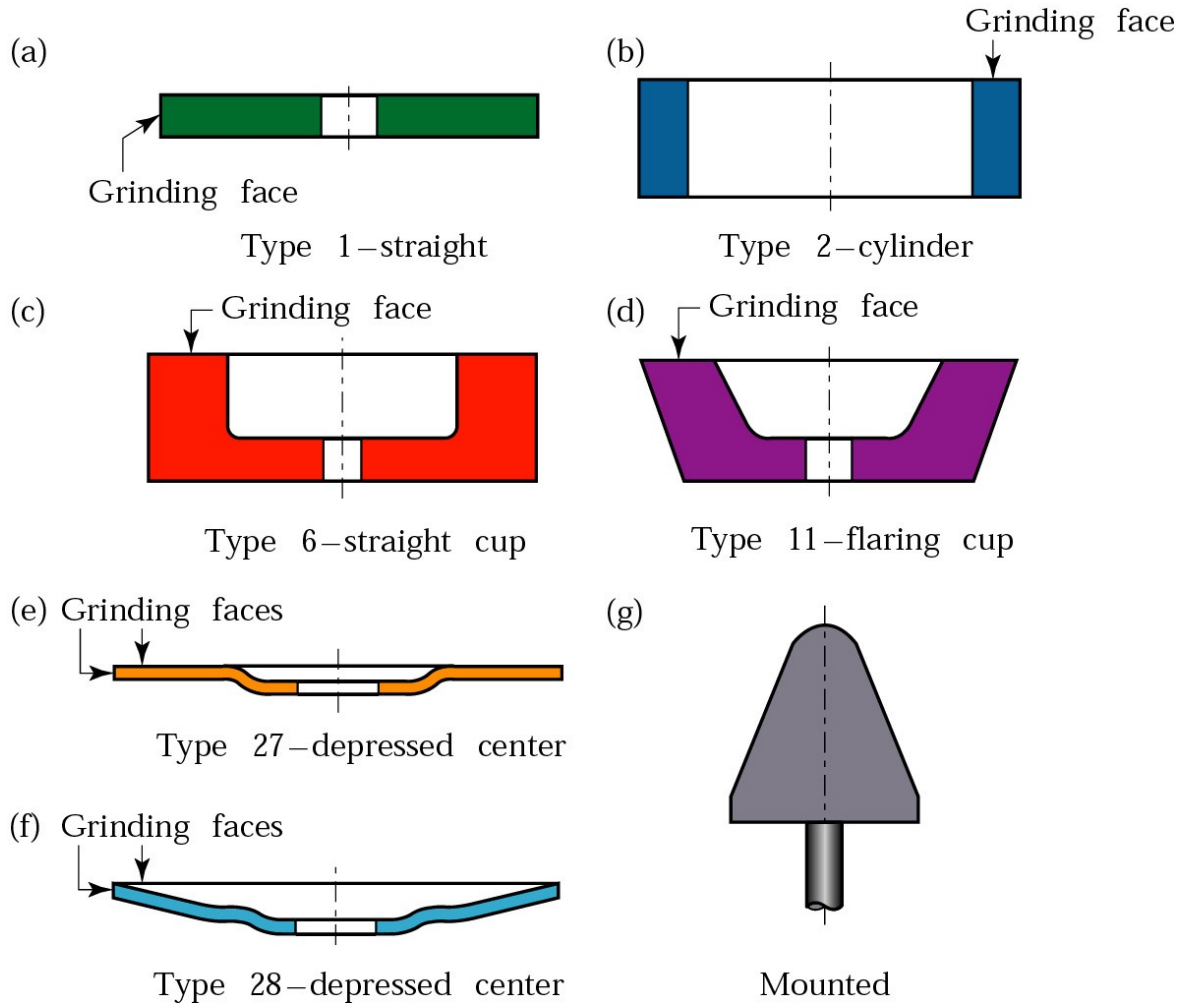

ME 338: Manufacturing Processes II  
Instructor: Ramesh Singh; Notes: Profs.  
Singh/Melkote/Colton



# Grinding Wheel Information



SD 120 - R 100 B 69 1/8

## Type of Manufactured Abrasive

(Optional prefix letter indicates exact type of abrasive)

D = Diamond  
B = Cubic Boron Nitride

### Examples

SD - Friable Diamond  
ASD or A2D - Ni Clad  
ASDC - Cu Clad  
PD - Natural Diamond

Working depth of abrasive

Manufacturer's Code to indicate special bond modification

### Bond Type

B = Resin  
V = Vitrified  
M = Metal

Concentration

A ..... GRADE ..... Z  
(Soft) (Hard)

Grit Size



# Correctly Mounted Wheel

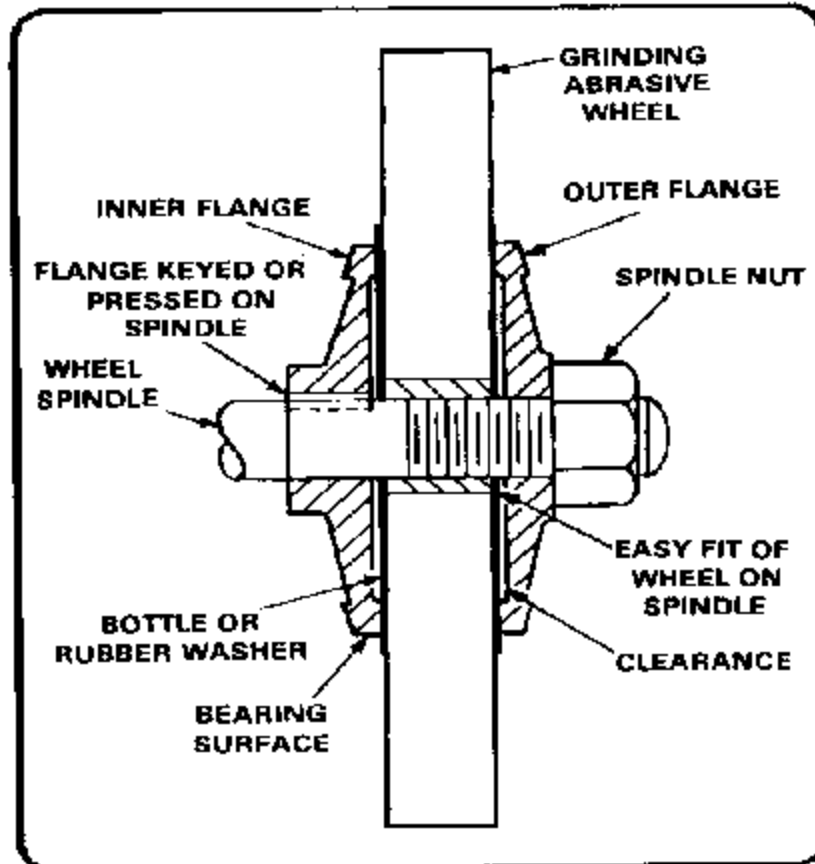
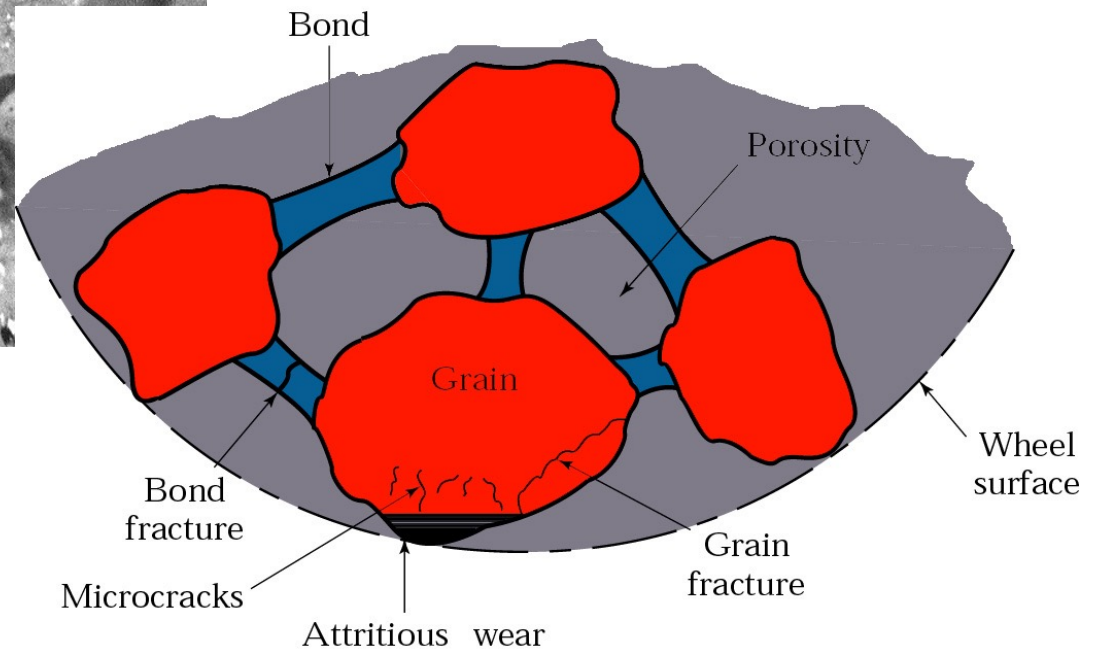
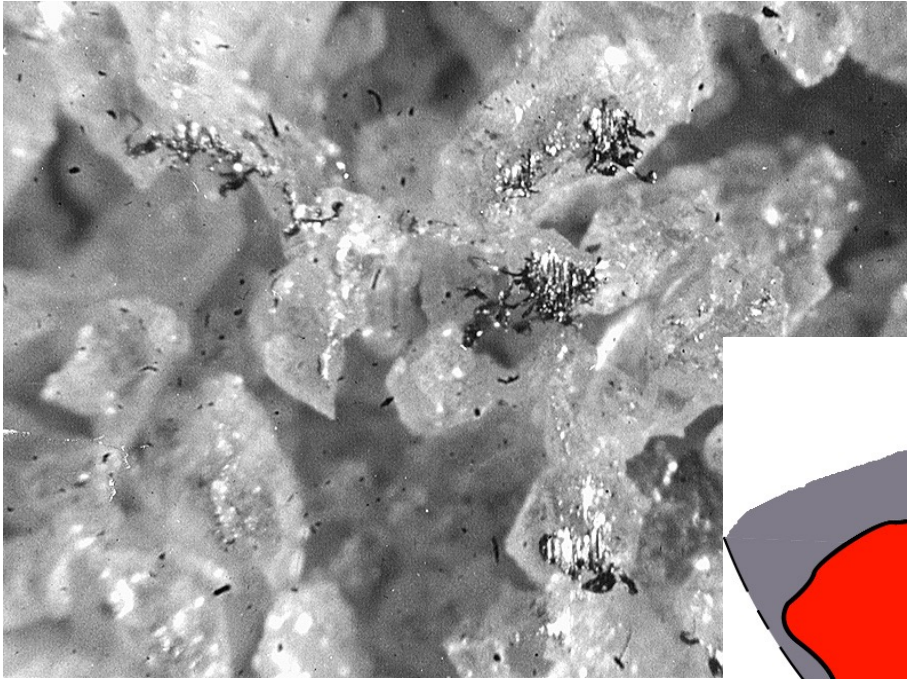

Figure 5-12. Correctly mounted wheel.



# Grinding Wheel Surface



ME 338: Manufacturing Processes II  
Instructor: Ramesh Singh; Notes: Profs.  
Singh/Melkote/Colton



# Grind Wheel Dressing

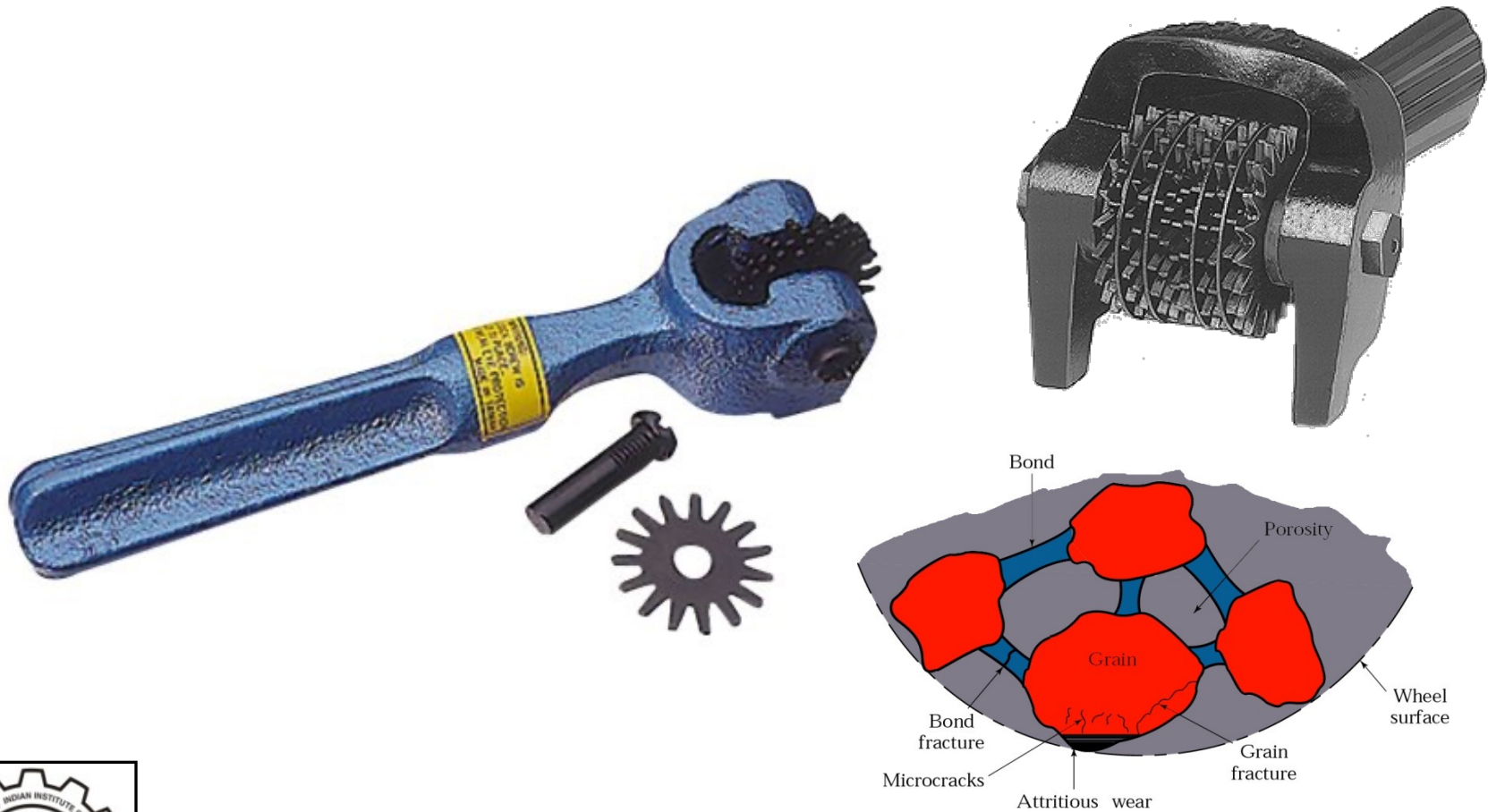

ME 338: Manufacturing Processes II  
Instructor: Ramesh Singh; Notes: Profs.  
Singh/Melkote/Colton



# Grinding Wheel Dressing

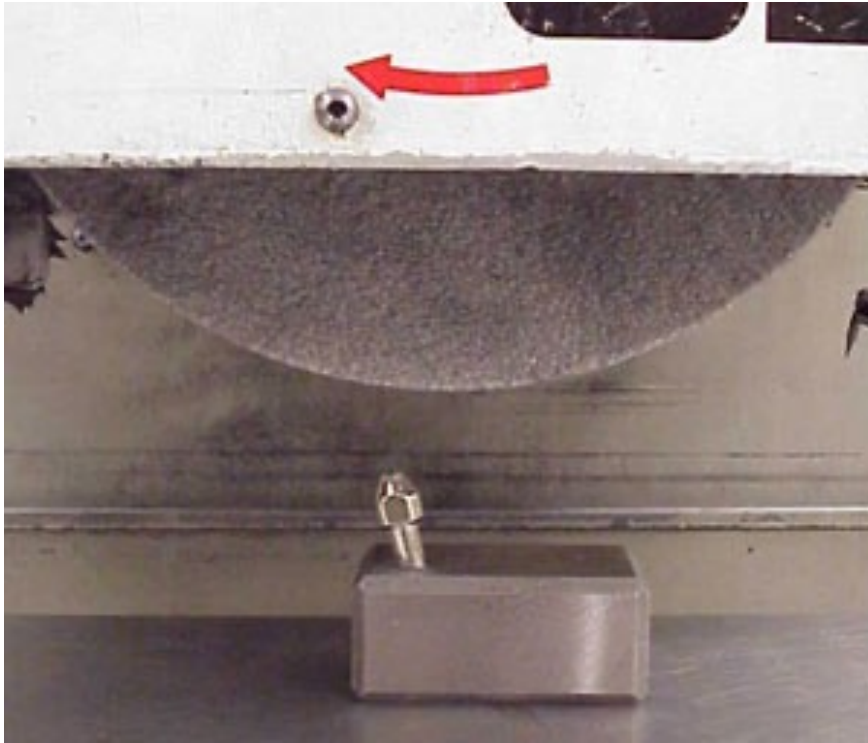

# Grinding Chips

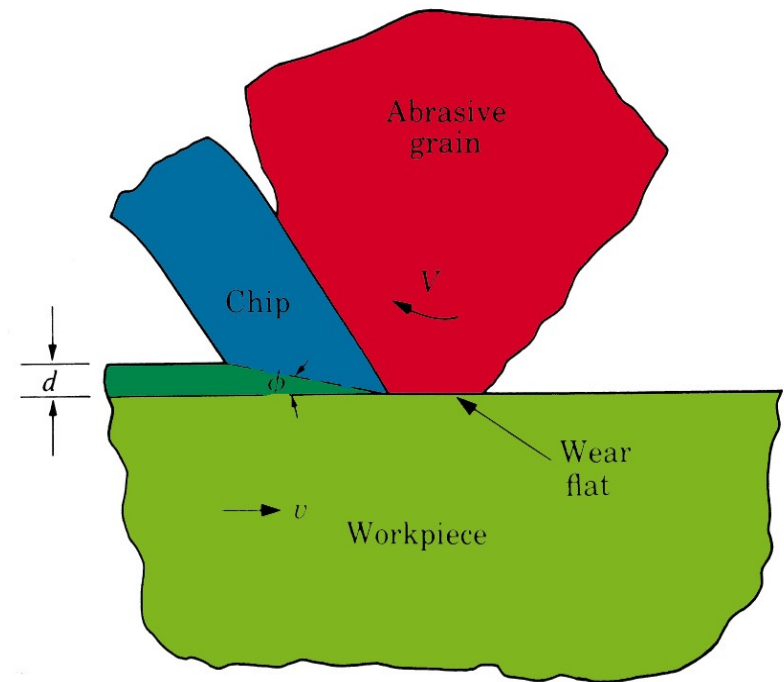
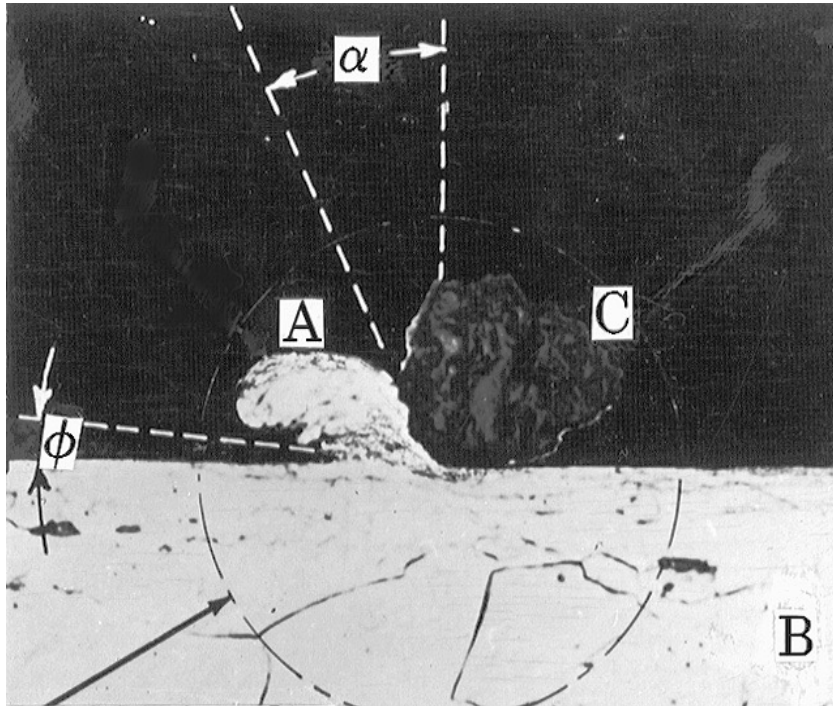

# Chip formation geometry

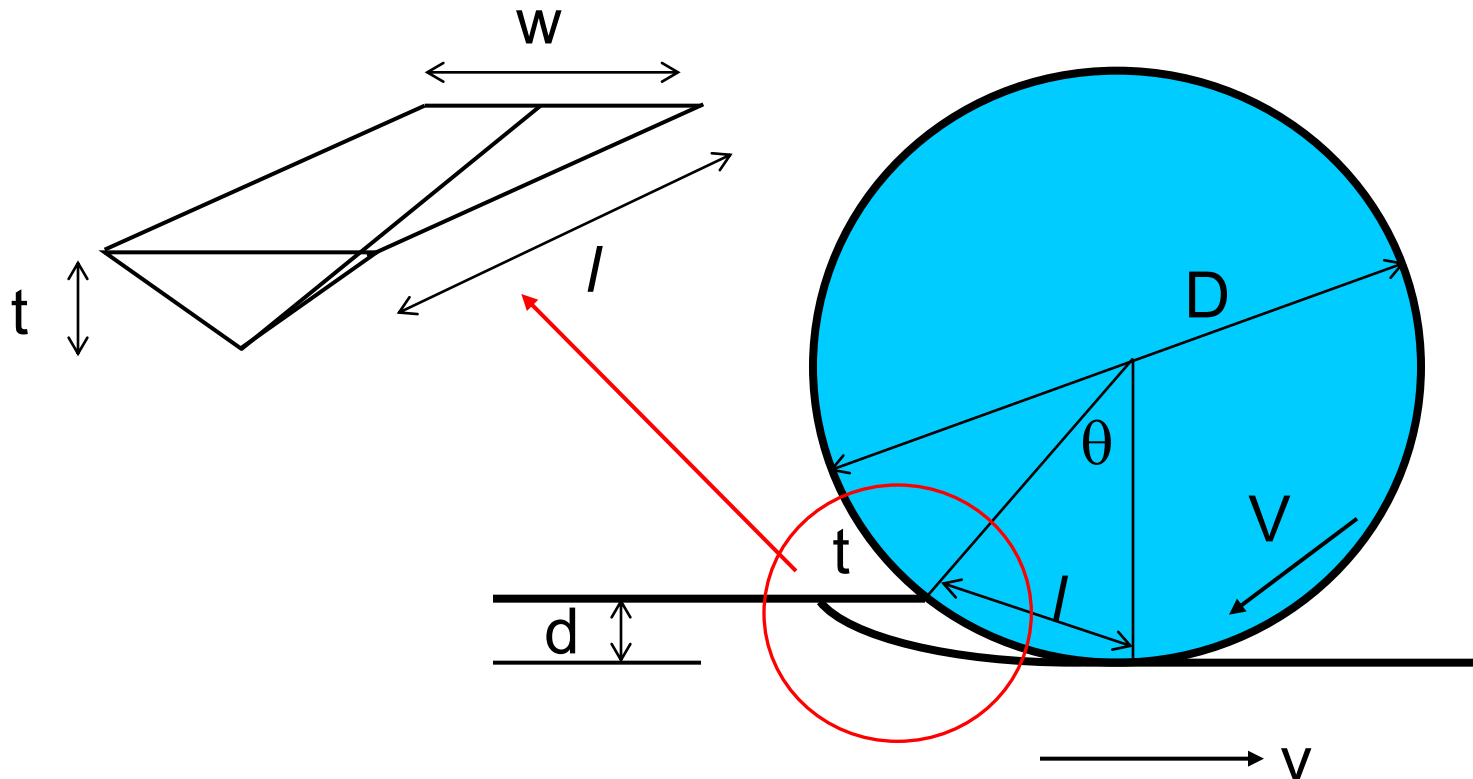

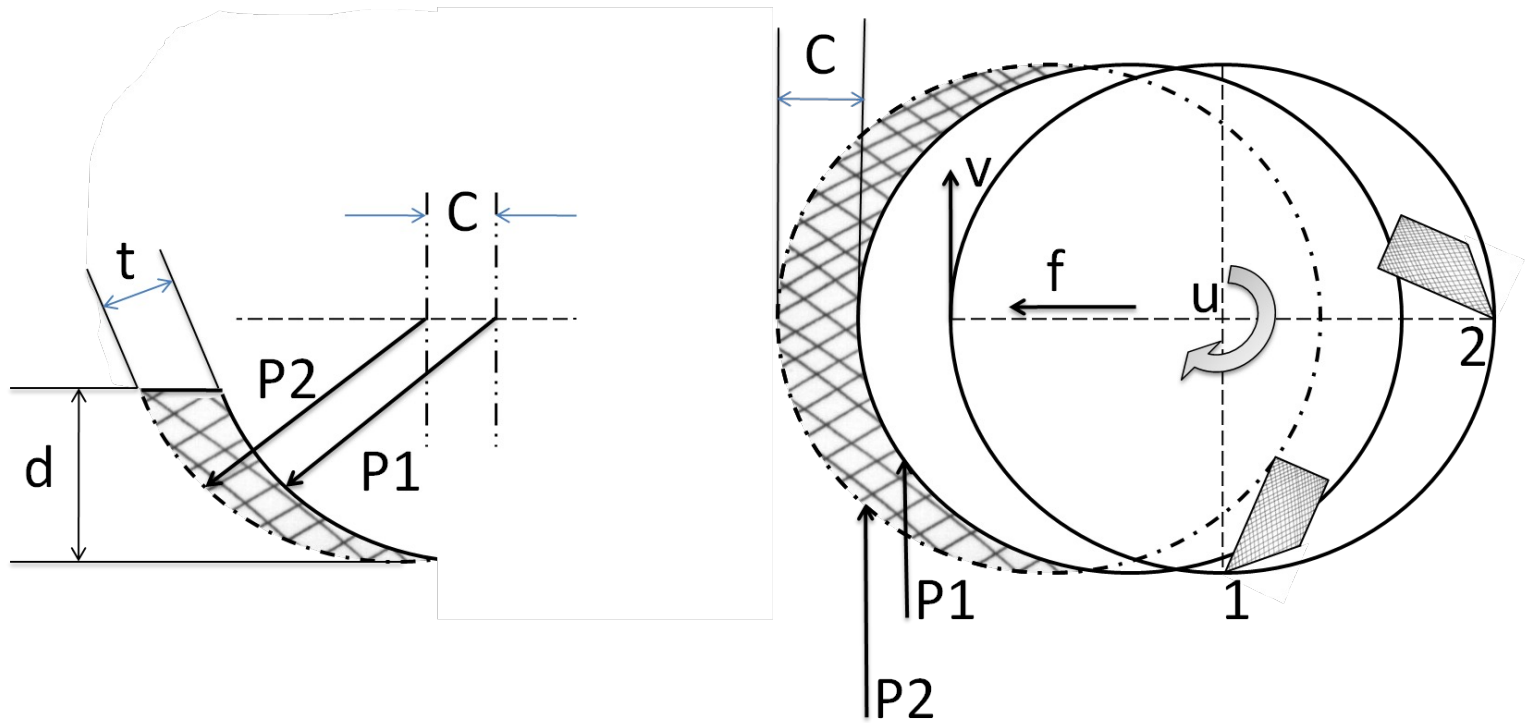

# Chip geometry

- As with rolling contact length, the chip length,  $l$ 
  - $D$  = wheel diameter,  $d$  = depth of cut

$$l = \sqrt{D \cdot d}$$

- Material removal rate,  $MRR$ 
  - $v$  = workpiece velocity,  $d$  = depth of cut,  $b$  = width of cut

$$MRR = v \cdot d \cdot b$$



# Material removal rate

- The chips have a triangular cross-section, and ratio ( $r$ ) of chip thickness ( $t$ ) to chip width ( $w$ )

$$r = \frac{w}{t} \approx 10 \text{ to } 20$$

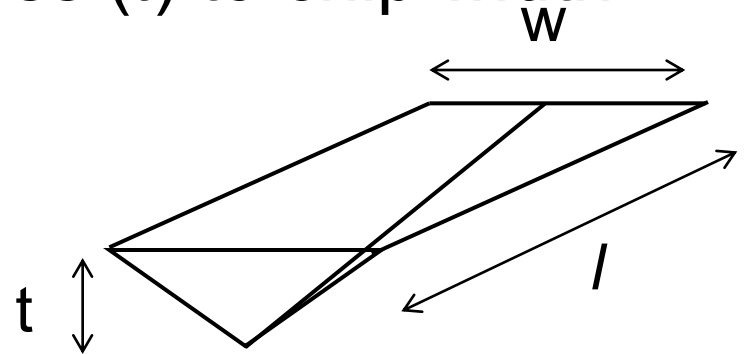

- So, the average volume per chip

$$Vol_{chip} = \frac{1}{2} w \cdot \frac{1}{2} t \cdot l = \frac{1}{4} wtl$$



# Chips

- The number of chips removed per unit time ( $n$ ), where  $c$  = number of cutting edges (grains) per unit area (typ. 0.1 to 10 per mm<sup>2</sup>, and  $V$  = peripheral wheel velocity

$$n = V \cdot b \cdot c$$



# Combining

$$MRR = v \cdot d \cdot b = n \cdot Vol_{chip}$$

$$v \cdot d \cdot b = Vbc \cdot \frac{1}{4} wtl$$

$$w = r \cdot t \quad l = \sqrt{D \cdot d}$$

$$v \cdot d \cdot b = V \cdot c \cdot b \cdot \frac{1}{4} r \cdot t \cdot t \cdot \sqrt{D \cdot d}$$



# Chip thickness

$$t^2 = \frac{4v \cdot d}{V \cdot c \cdot r \sqrt{D \cdot d}}$$

or

$$t = \sqrt{\frac{4v}{V \cdot c \cdot r}} \sqrt{\frac{d}{D}}$$



# Specific grinding energy, $u$

- Consist of chip formation, plowing, and sliding

$$u = u_{chip} + u_{plowing} + u_{sliding}$$



# Total grinding force

- Get force from power

$$Power = u \times MRR$$

$$F_{grinding} \cdot V = u \times v \cdot d \cdot b$$

$$F_{grinding} = u \times \frac{v \cdot d \cdot b}{V}$$



# Total grinding force

- From empirical results, as  $t$  decreases, the friction component of  $u$  increases

$$u \propto \frac{1}{t} \quad \text{or} \quad u = K_1 \cdot \frac{1}{t}$$

substituting

$$F_{grinding} = K_1 \cdot \frac{1}{t} \cdot \frac{v \cdot d \cdot b}{V}$$



# Total grinding force

Substituting for  $t$

$$F_{grinding} = K_1 \cdot \frac{1}{\sqrt{\frac{4v}{V \cdot c \cdot r}} \cdot \sqrt{\frac{d}{D}}} \cdot \frac{v \cdot d \cdot b}{V}$$

rearranging

$$F_{grinding} = K_1 \cdot b \cdot \sqrt{\frac{d \cdot c \cdot r \cdot v}{4V}} \cdot \sqrt{D \cdot d}$$



# Force on a grain

- The force per grain can be calculated

$$F_{\text{grain}} = u \times \text{Area}$$

$$F_{\text{grain}} = u \times \frac{1}{2} wt \quad \text{and} \quad w = rt$$
$$u = K_1 \cdot \frac{1}{t}$$

$$F_{\text{grain}} = K_1 \cdot \frac{1}{t} \times \frac{1}{2} \cdot r \cdot t \cdot t$$



# Force on a grain

substituting for  $t$ , and rearranging

$$F_{grain} = \frac{K_1}{2} \cdot r \cdot \sqrt{\frac{4v}{V \cdot c \cdot r}} \sqrt{\frac{d}{D}}$$

$$F_{grain} = K_1 \cdot \sqrt{\frac{v \cdot r}{V \cdot c}} \sqrt{\frac{d}{D}}$$



# Grinding temperature

- Temperature rise goes with energy delivered per unit area

$$\Delta T = K_2 \cdot \frac{\text{Energy input}}{\text{area}}$$

$$\Delta T = K_2 \cdot \frac{u \times b \cdot l \cdot d}{b \cdot l} = K_2 \cdot K_1 \cdot \frac{1}{t} \cdot d$$

$$\Delta T = K_1 \cdot K_2 \cdot d \cdot \frac{1}{\sqrt{\frac{4v}{Vcr} \sqrt{\frac{d}{D}}}}$$



# Grinding temperature

- Rearranging

$$\Delta T = K_1 \cdot K_2 \cdot \sqrt{\frac{V \cdot c \cdot r \cdot d}{4v}} \sqrt{D \cdot d}$$

- Temperatures can be up to 1600°C, but for a short time.



# Grinding – Ex. 1-1

- You are grinding a steel, which has a specific grinding energy ( $u$ ) of  $35 \text{ W-s/mm}^3$ .
- The grinding wheel rotates at 3600 rpm, has a diameter ( $D$ ) of 150 mm, thickness ( $b$ ) of 25 mm, and ( $c$ ) 5 grains per  $\text{mm}^2$ . The motor has a power of 2 kW.
- The work piece moves ( $v$ ) at 1.5 m/min. The chip thickness ratio ( $r$ ) is 10.
- Determine the grinding force and force per grain.
- Determine the temperature ( $K_2$  is  $0.2^\circ\text{K-mm/N}$ ).  
Room temperature is  $20^\circ\text{C}$ .



# Grinding – Ex. 1-2

- First we need to calculate the depth of cut. We can do this from the power.

$$Power = u \times MRR = u \cdot v \cdot d \cdot b$$

$$2000 W = 35 \frac{W - s}{mm^3} \cdot 1.5 \frac{m}{min} \cdot d \cdot 25 mm \times 10^6 \frac{mm^2}{m^2} \times \frac{min}{60 sec}$$

$$d = 91.4 \times 10^{-6} m$$



# Grinding – Ex. 1-3

- Now for the total grinding force

$$F_{grinding} = u \times \frac{v \cdot d \cdot b}{V}$$

$$F_{grinding} = 35 \frac{W - s}{mm^3} \cdot \frac{1500 \frac{mm}{min} \cdot 91.4 \times 10^{-3} mm \cdot 25 mm}{3600 \frac{rev}{min} \cdot 150\pi \frac{mm}{rev} \cdot \frac{m}{1000 mm}}$$

$$F_{grinding} = 70.7 N$$



# Grinding – Ex. 1-4

- Next, the force per grain

$$F_{grain} = u \times \frac{1}{2} wt \quad \text{and} \quad w = rt$$

$$F_{grain} = u \times \frac{1}{2} r \cdot t \cdot t$$

we need  $t$

$$t = \sqrt{\frac{4v}{V \cdot c \cdot r}} \sqrt{\frac{d}{D}} = \sqrt{\frac{4 \cdot 1500 \frac{mm}{min}}{3600 \cdot 150 \pi \frac{mm}{min} \cdot 5 \frac{grains}{mm^2} \cdot 10}} \sqrt{\frac{91.4 \times 10^{-3} mm}{150 mm}}$$

$$t = 1.32 \times 10^{-3} mm$$



# Grinding – Ex. 1-5

- Substituting

$$F_{grain} = u \times \frac{1}{2} r \cdot t \cdot t = 35 \cdot \frac{1}{2} \cdot 10 \cdot \left(1.32 \times 10^{-3}\right)^2$$

$$F_{grain} = 3.05 \times 10^{-4} J / mm$$



# Grinding – Ex. 1-6

- For the temperature, we need  $K_1$  and  $K_2$ .  $K_2$  is given, so we need to calculate  $K_1$ .

$$F_{grain} = u \times \frac{1}{2} \cdot r \cdot t \cdot t = K_1 \cdot \frac{1}{t} \times \frac{1}{2} \cdot r \cdot t \cdot t = K_1 \cdot \frac{1}{2} \cdot r \cdot t$$

$$3.05 \times 10^{-1} N = K_1 \cdot \frac{1}{2} \cdot 10 \cdot 1.32 \times 10^{-6} m$$

$$K_1 = 46.2 \times 10^3 \frac{N}{m}$$



# Grinding – Ex. 1-7

- substituting

$$\Delta T = K_2 \cdot K_1 \cdot \frac{1}{t} \cdot d$$

$$\Delta T = 0.2 \frac{K - m}{N} \cdot 46.2 \frac{N}{m} \cdot \frac{1}{1.32 \times 10^{-6} m} \cdot 91.4 \times 10^{-6} m = 640^\circ K$$

$$T = T_{initial} + \Delta T = 20 + 640 = 660^\circ C$$



# Honing and Superfinishing

Honing tool used to improve the surface finish of bored or ground holes.

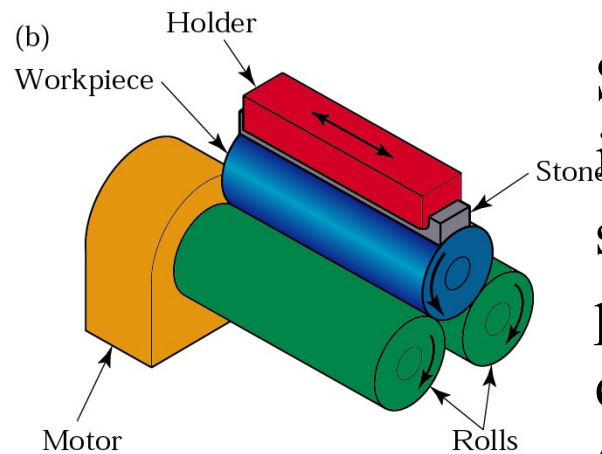
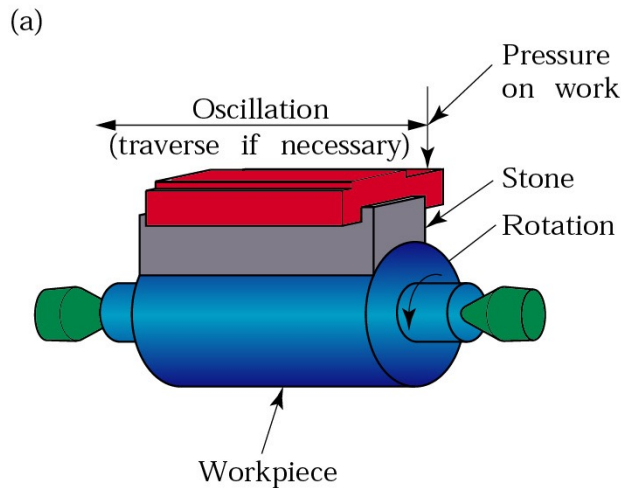
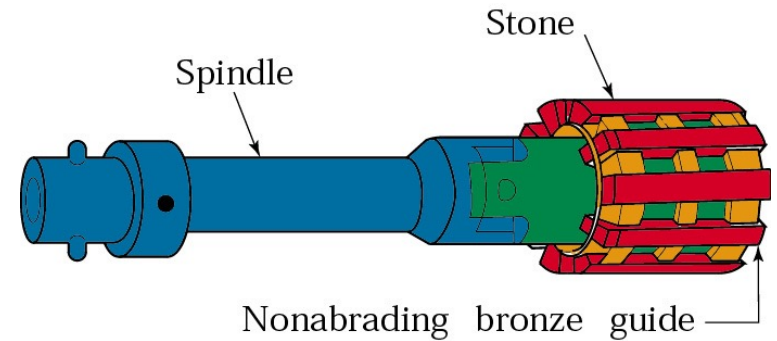

Schematic illustrations of the superfinishing process for a cylindrical part. (a) Cylindrical microhoning, (b) Centerless microhoning.



# Lapping

(a) Schematic illustration of the lapping process. (b) Production lapping on flat surfaces. (c) Production lapping on cylindrical surfaces.

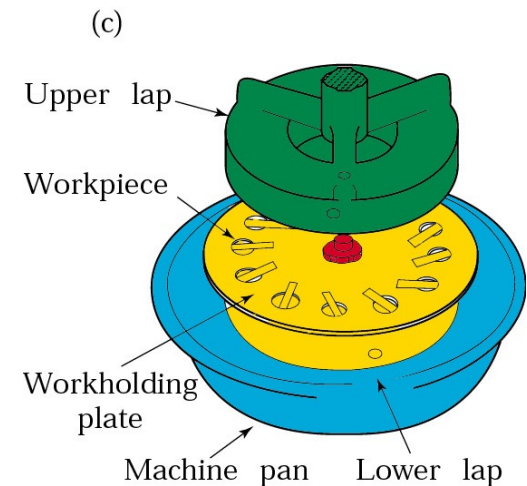
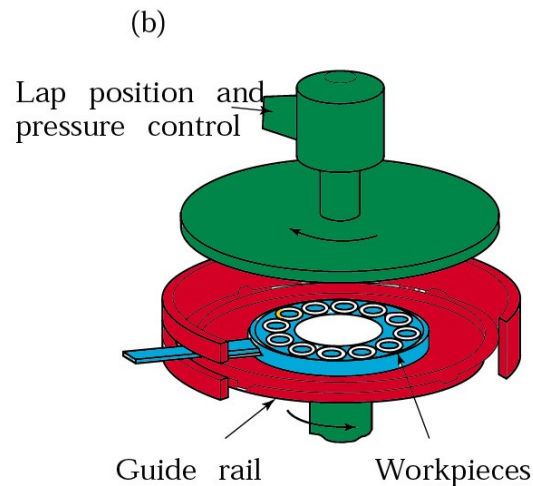
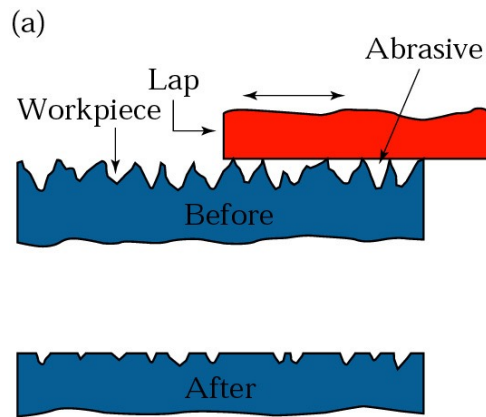

# Polishing Using Magnetic Fields

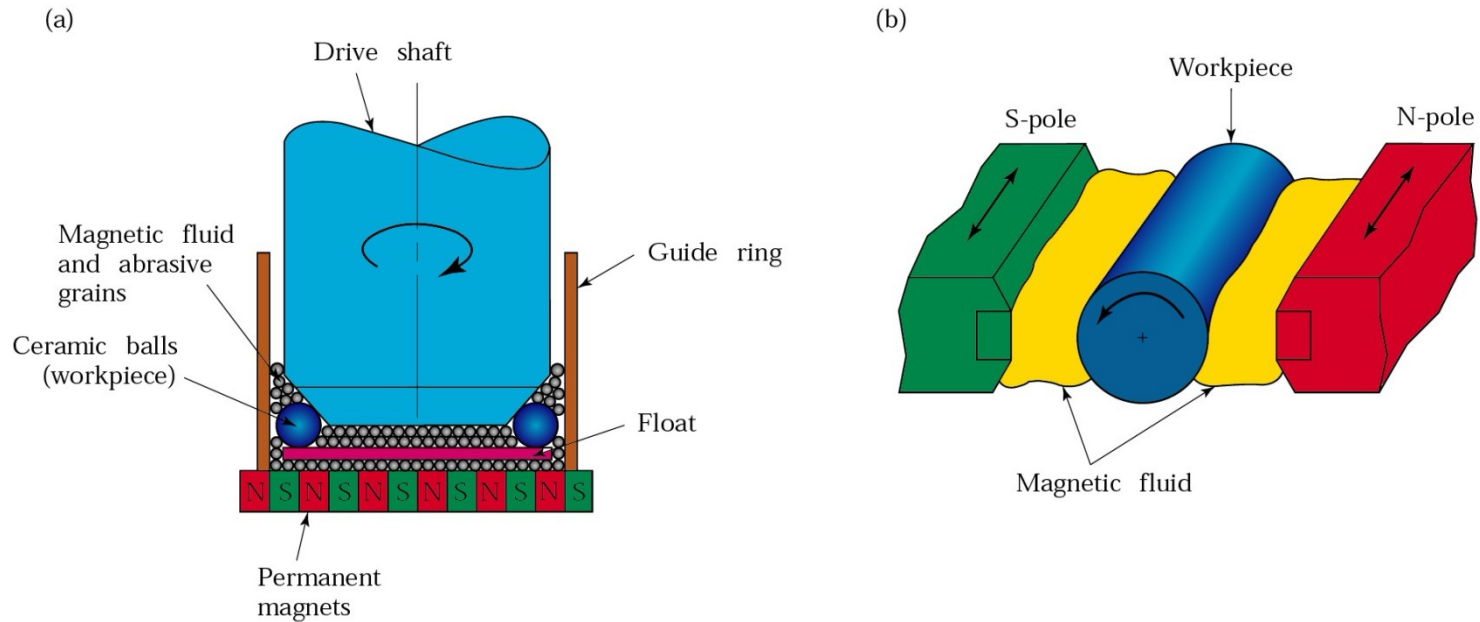

Schematic illustration of polishing of balls and rollers using magnetic fields. (a) Magnetic float polishing of ceramic balls. (b) Magnetic-field-assisted polishing of rollers. *Source:* R. Komanduri, M. Doc, and M. Fox.



# Abrasive-Flow Machining

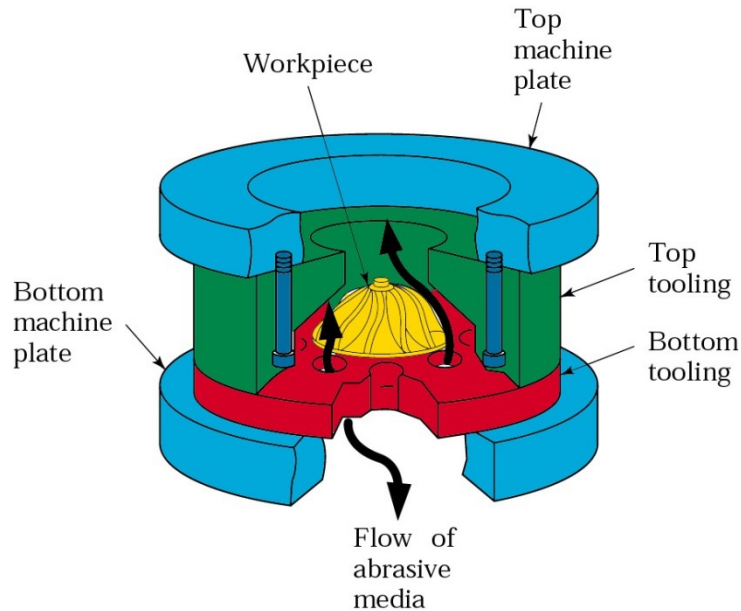

Schematic illustration of abrasive flow machining to deburr a turbine impeller. The arrows indicate movement of the abrasive media. Note the special fixture, which is usually different for each part design. *Source:* Extrude Hone Corp.



# Robotic Deburring

A deburring operation on a robot-held die-cast part for an outboard motor housing, using a grinding wheel. Abrasive belts or flexible abrasive radial-wheel brushes can also be used for such operations. *Source:* Courtesy of Acme Manufacturing Company and *Manufacturing Engineering Magazine*, Society of Manufacturing Engineers.

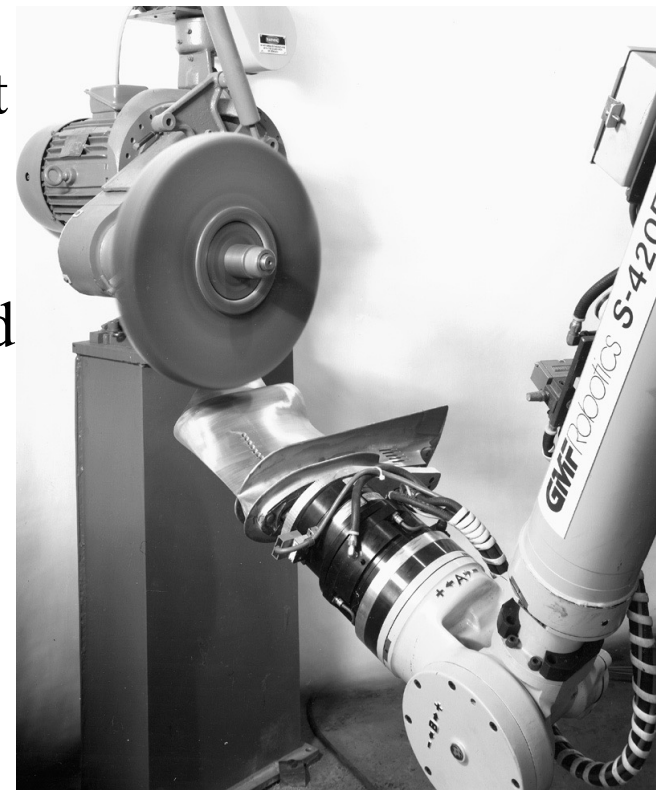

# Conformal Hydrodynamic Nanopolishing: Case-study

## Applications

- Optics
- Defence & Nuclear
- Electronics
- Industrial

## Existing Methods

- Diamond Turning
- Precision Grinding
- Lapping
- Ion Beam Polishing
- Spot Hydrodynamic Polishing

## Challenges

- Most processes can polish only flat surfaces; concave/profiled surfaces are difficult to superfinish
- Concave surface on hard brittle materials, such as single crystal sapphire can not be finished via form grinding due to process-induced cracks
- Diamond turning center can be used for non ferrous materials but it is a super-precision machine-tool (The equipment cost is ~ 20 crores besides the expensive operational cost)



# Conformal Hydrodynamic Nanopolishing Process and Machine

## Process Description

- Improvement over existing spot hydrodynamic polishing methods
- Superfinish hard and brittle concave surfaces, specially, sapphire and hardened steels
- Mitigates existing surface microcracks
- Polishing action due to elasto-hydrodynamic film in the slurry submerged rotating conformal contact (silicone ball in the cavity being polished)

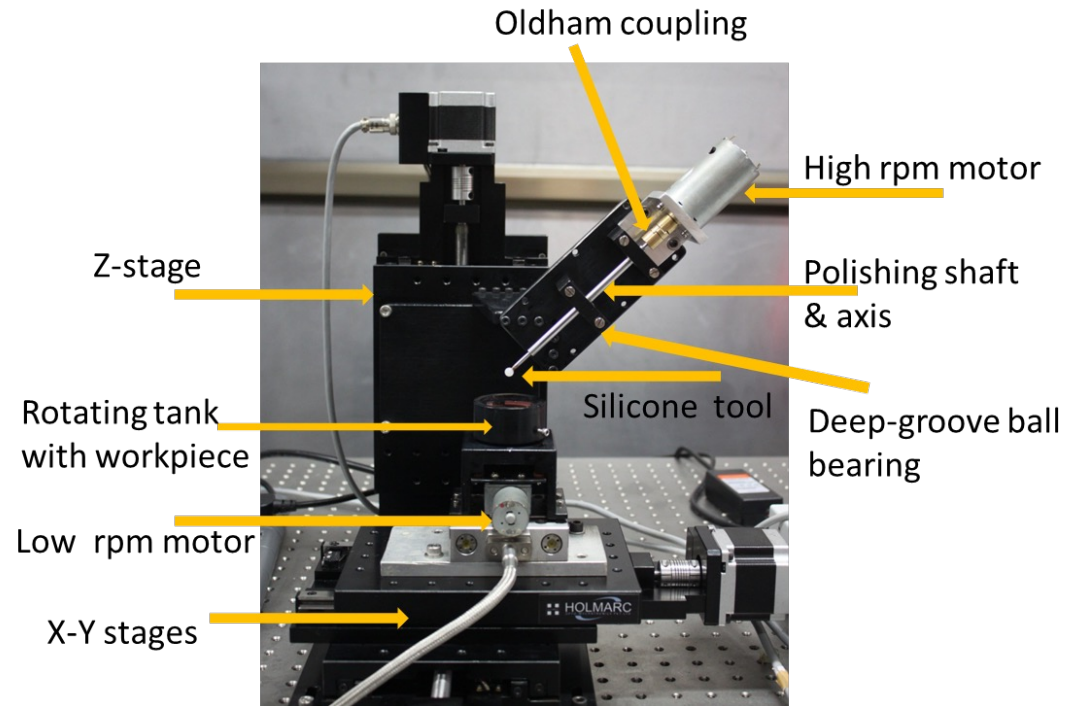

2<sup>nd</sup> Generation Conformal Hydrodynamic Nanopolishing Machine  
Delivered to Precision Engineering Division BARC  
(designed and fabricated in the Machine Tools Lab  
at IIT Bombay)

ME 338: Manufacturing Processes II  
Instructor: Ramesh Singh; Notes: Profs.  
Singh/Melkote/Colton



# Novelty and Technology Breakthrough

- Existing hydrodynamic polishing employs spot polishing unable to polish small cavities (< 6mm in dia)
  - More than 3 degrees of freedom required to polish the entire cavity effectively
  - Small actuation system and polishing tool is required
- Conformal contact has a rotating soft tool which conforms to the shape of the cavity
- Axis of this tool is inclined at  $45^\circ$  and the workpiece is rotated inside a slurry filled tank which ensures non-zero relative motion between tool and workpiece at every location in the cavity
- The entire cavity can be polished at once which will be much cheaper and faster than programming the tool path
- Alternative to expensive Diamond Turning
- Can finish wide range of materials ceramics (sapphire, glass) and hardened steels



# Technology Outcomes

- Superfinished surfaces in steels ( $< 3\text{nm}$  3D surface roughness)
- Crack-free surface of  $< 100\text{nm}$  3D surface roughness in single crystal sapphire cavity
- Process knowhow and machine transferred to Precision Engineering Division, BARC for strategic applications in a nuclear device
- The superfinished obtained at a fraction of cost of Diamond turning
- It can also be used by gem polishers which could reduce the health hazard by reducing the dust inhalation and automation is possible

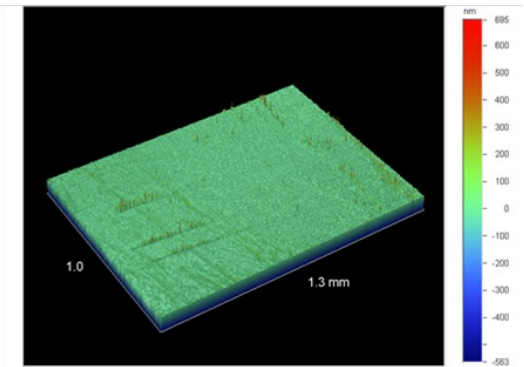
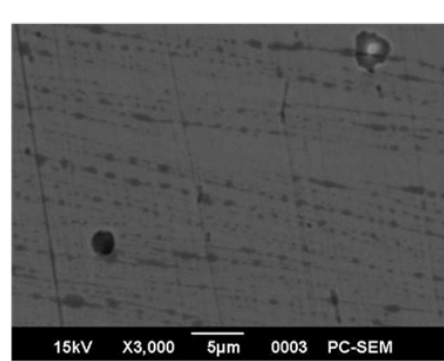

## Nanometric finish on hardened steel

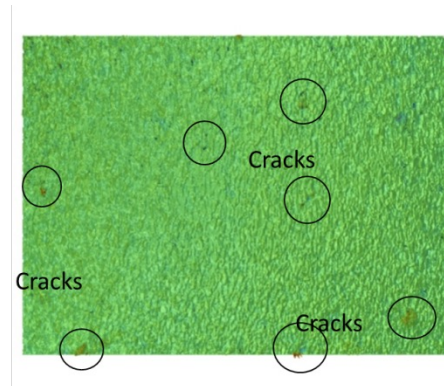

Pre-polished Surface

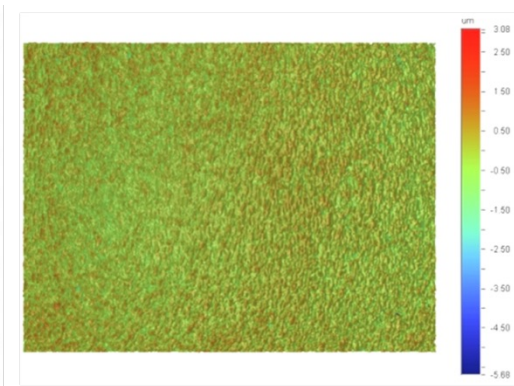

After Polishing

## Crack-free superfinished surface on single crystal sapphire cavity



# Economics of Grinding and Finishing Operations

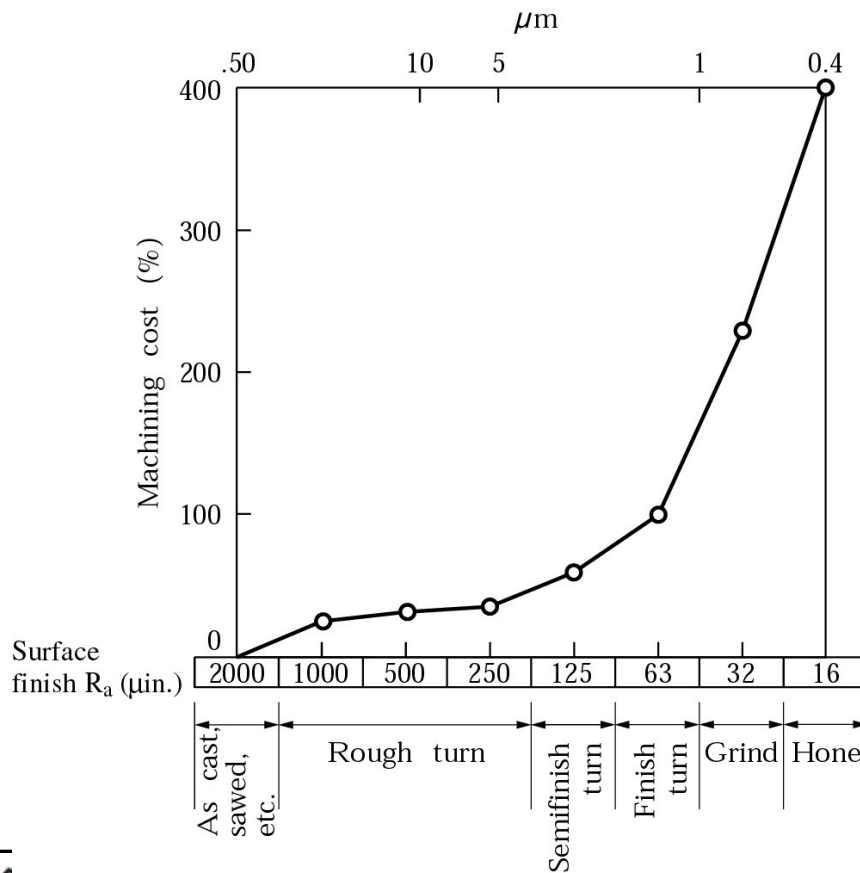

Increase in the cost of machining and finishing a part as a function of the surface finish required. This is the main reason that the surface finish specified on parts should not be any finer than necessary for the part to function properly.



# Summary

- Overview of processes
- Analysis of process
- Example problem

